

BELL 212



MAINTENANCE MANUAL

VOLUME 1

GENERAL INFORMATION

NOTICE

The instructions set forth in this manual, as supplemented or modified by Alert Service Bulletins (ASB) or other directions issued by Bell Textron Inc. and Airworthiness Directives (AD) issued by the applicable regulatory agencies, shall be strictly followed.

COPYRIGHT NOTICE
COPYRIGHT 2021
BELL TEXTRON INC. AND
BELL TEXTRON CANADA LIMITED.

ALL RIGHTS RESERVED



POST OFFICE BOX 482 • FORT WORTH, TEXAS 76101

REISSUE — 7 JUNE 1993
REVISION 20 — 25 AUG 2021



PROPRIETARY RIGHTS NOTICE

These data are proprietary to Bell Textron Inc. Disclosure, reproduction, or use of these data for any purpose other than helicopter operation or maintenance is forbidden without prior written authorization from Bell Textron Inc.

DESTINATION CONTROL STATEMENT

WARNING — This document contains technical data whose export is restricted by the Arms Export Control Act (Title 22, U.S.C., Sec 2751, et. seq.) or the Export Administration Act of 1979, as amended, Title 50, U.S.C., App. 2401 et. seq. Violations of these export laws are subject to severe criminal penalties. Disseminate in accordance with provisions of DoD Directive 5230.25.



WARNING

THIS MANUAL APPLIES ONLY TO HELICOPTERS AND COMPONENTS MAINTAINED IN ACCORDANCE WITH BELL TEXTRON INC. APPROVED PROCEDURES USING BELL APPROVED PARTS.

ALL INSPECTION, REPAIR AND OVERHAUL PROCEDURES PUBLISHED BY BELL, INCLUDING PART RETIREMENT LIFE, ARE BASED SOLELY ON THE USE OF BELL PARTS THAT HAVE BEEN MAINTAINED USING BELL APPROVED DATA. THE DATA PUBLISHED HEREIN OR OTHERWISE SUPPLIED BY BELL IS NOT APPLICABLE TO NON-BELL PARTS OR PARTS THAT HAVE BEEN REPAIRED USING DATA AND/OR PROCESSES NOT APPROVED BY BELL.

BELL IS NOT RESPONSIBLE FOR ANY PART OTHER THAN THOSE THAT IT HAS APPROVED.

BEFORE PERFORMING ANY PROCEDURE CONTAINED IN THIS MANUAL YOU MUST INSPECT THE AFFECTED PARTS AND RECORDS FOR EVIDENCE OF ANY MANUFACTURE, REPAIR, REWORK OR USE OF A PROCESS NOT APPROVED BY BELL.

IF YOU IDENTIFY OR SUSPECT THE USE OF PARTS NOT AUTHORIZED BY BELL, EITHER REMOVE THE AFFECTED ITEM FROM THE AIRCRAFT OR OBTAIN INSTRUCTIONS FOR CONTINUED AIRWORTHINESS FROM THE MANUFACTURER OR THE ORGANIZATION THAT APPROVED THE REPAIR.



CUSTOMER SUPPORT AND SERVICES

Flying smart means that no matter where you are, or what time it is, you can make a call and get additional information, clarification, or advice on a technical or operational issue concerning your helicopter or information contained in our Technical Publications. Product Support Engineering (PSE) is just a phone call away and may be contacted as follows:

Commercial Models

Phone: 450-437-2862 or 800-363-8023 (U.S./Canada)

Fax: 450-433-0272

E-mail: productsupport@bellflight.com

Model 210, HUEY II, and All Bell's Active and Surplus Military Medium Helicopter Models

Phone: 817-280-3548

Fax: 817-280-2635

E-mail: mts-medium@bellflight.com

Model OH-58, TH-67, TH-57, Both Active and Surplus Military

Phone: 817-280-3548

Fax: 817-280-2635

E-mail: mts-light@bellflight.com

For additional information on Customer Support and Services as well as Product Support Engineering (PSE) and your local Customer Service Engineering (CSE) network, please access <https://www.bellflight.com/support>.



LOG OF REVISIONS

Insert latest revision pages and dispose of superseded ones.

On a revised page, the text and/or illustration affected by the latest revision is shown by a vertical line. A revised page with only a vertical line next to the page number indicates that text has shifted or that non-technical correction(s) were made on that page.

Original 0 01 JAN 76	Revision 19 06 APR 83	Revision 4 01 MAY 96
Revision 1 20 MAY 76	Revision 20 13 MAY 83	Revision 5 25 SEP 97
Revision 2 28 JUN 76	Revision 21 26 JUL 83	Revision 6 14 FEB 02
Revision 3 16 AUG 76	Revision 22 31 MAR 84	Revision 7 28 NOV 03
Revision 4 03 DEC 76	Revision 23 15 MAY 84	Revision 8 02 AUG 04
Revision 5 17 JAN 77	Revision 24 01 OCT 84	Revision 9 08 AUG 08
Revision 6 28 MAY 77	Revision 25 07 NOV 84	Revision 10 18 SEP 09
Revision 7 03 DEC 77	Revision 26 10 SEP 85	Revision 11 30 APR 10
Revision 8 15 AUG 78	Revision 27 15 MAR 87	Revision 12 08 JUN 10
Revision 9 28 SEP 78	Revision 28 01 APR 88	Revision 13 16 SEP 10
Revision 10 21 FEB 80	Revision 29 28 NOV 88	Revision 14 26 JUN 13
Revision 11 16 JUN 80	Revision 30 18 OCT 91	Revision 15 29 NOV 13
Revision 12 02 AUG 80	Revision 31 10 JAN 92	Revision 16 15 NOV 18
Revision 13 17 AUG 81	Revision 32 02 OCT 92	Revision 17 30 OCT 19
Revision 14 01 OCT 81	Revision 33 15 DEC 92	Revision 18 15 MAY 20
Revision 15 30 OCT 81	Reissue 0 07 JUN 93	Revision 19 15 JUL 21
Revision 16 21 DEC 81	Revision 1 14 OCT 94	Revision 20 25 AUG 21
Revision 17 01 FEB 82	Revision 2 03 FEB 95	
Revision 18 01 APR 83	Revision 3 01 AUG 95	

LOG OF PAGES

Page No.	Rev No.	Page No.	Rev No.	Page No.	Rev No.
VOLUME 1					
Cover	19	Chapter 4		25 – 26	14
Title	20	1/2.....	19	27 – 49	18
PN	18	3 – 4.....	19	50	14
Warning.....	18	5.....	19	51/52	14
CSS.....	18	6 – 7.....	5	53	18
A – F.....	20	8.....	19	54	14
Help.....	14	9 – 11.....	5	55 – 60	18
Customer Feedback.....	18	12.....	19	60A – 60B	18
Helicopter Sales Notice.....	18	Chapter 5		61	14
Warranty 1 – 3.....	18	1 – 2.....	18	62 – 63	18
BR	20	3/4.....	18	64 – 68	14
TR	17	5 – 6.....	14	69	18
i/ii.....	17	7 – 8.....	18	70	14
Chapter 1		9 – 10.....	19	71	19
1/2.....	3	11/12.....	14	72 – 78	14
3/4.....	0	13.....	14	79 – 91	18
5 – 6.....	3	14.....	18	92 – 93	14
7 – 8.....	0	15 – 23.....	14	94	18
		24.....	18	95	14
				96	18



LOG OF PAGES (CONT)

Page No.	Rev No.	Page No.	Rev No.	Page No.	Rev No.
97/98.....	14	186	17	4.....	5
99 – 104.....	18	187/188.....	14	5/6.....	0
104A – 104D.....	18	188A – 188B	18	7/8.....	0
105.....	18	189/190	14		
106.....	14	191 – 194	14	Chapter 11	
107 – 108.....	18	195/196.....	14	1/2.....	0
109 – 114.....	14	197 – 206	14	3.....	14
115.....	19	207/208.....	14	4.....	11
116.....	14	209 – 214	14	5.....	15
117/118	14	215	18	6 – 8.....	0
119 – 121	14	216	14	9.....	15
122.....	16	217/218.....	14	10.....	0
123 – 126.....	18	219 – 224	14	11.....	15
126A – 126B	16	225/226.....	14	12 – 14.....	0
127/128.....	18	227 – 232	14	15 – 18.....	15
129/130.....	14	233	19		
131 – 132.....	14	234	15	Chapter 12	
133/134.....	14			1.....	14
135 – 136.....	18	INDEX		2.....	11
137/138.....	19	1 – 22 (Deleted)	11	3.....	14
139/140.....	19	23/24 (Deleted)	11	4 – 5.....	11
140A – 140B	18			6 – 11.....	14
141/142.....	14	VOLUME 2		12.....	11
143/144.....	14	Cover	19	12A – 12D.....	14
145/146.....	14	Title	19	13 – 14.....	14
147/148.....	14	PN.....	18	15.....	11
149/150.....	14			16.....	15
151/152.....	14	Chapter 6		17 – 18.....	11
152A/152B.....	16	1/2	0	19/20.....	18
153 – 154.....	16	3 – 5	0		
155/156.....	14	6.....	15	Chapter 18	
157 – 158.....	14			1.....	11
159/160.....	18	Chapter 7		2.....	19
161/162.....	14	1/2	0	3/4.....	19
162A/162B.....	16	3 – 8	0	5.....	11
162C/162D	16			6 – 9.....	5
163 – 166.....	14	Chapter 8		10.....	11
167/168.....	14	1/2	0	11 – 13.....	5
169/170.....	14	3 – 4	0	14.....	11
171.....	19	5.....	3	14A – 14F	11
172 – 173.....	18	6 – 24	0	14G/14H	11
174.....	14			15.....	5
175/176.....	14	Chapter 9		16.....	11
176A/176B.....	16	1/2	0	17 – 25.....	5
176C/176D	16	3 – 6	0	26.....	11
177.....	14			27 – 29.....	5
178.....	19	Chapter 10		30.....	11
179/180.....	18	1/2	0	31 – 39.....	5
181 – 185.....	14	3.....	0	40.....	15



LOG OF PAGES (CONT)

Page No.	Rev No.	Page No.	Rev No.	Page No.	Rev No.
40A/40B	15	11	14	55/56	11
41 – 46	5	12 – 16	0	57 – 62	11
47– 48	15	17	10	63/64	11
48A/48B	15	18	15	65	14
49 –50	5	18A/18B	15	66	11
50A –50D	19	19	10	67 – 68	14
51 –52	19	20 – 24	11		
53	5	25	0	Chapter 52	
54	14	26	16	1 – 4	11
55 – 62	5	27 – 29	0	5 – 15	0
		30 – 33	11	16	11
VOLUME 3		34 – 36	0	17 – 21	0
Cover	18	37	11	22	11
Title	18	38 – 40	0	22A – 22B	11
PN	18	41 – 42	11	22C/22D	11
		43/44	11	23	0
Chapter 21				24	15
1 – 4	0	Chapter 29		25 – 32	0
5	3	1 – 2	14	33	11
6 – 12	0	3	11	34 – 38	0
13/14	0	4 – 10	0	39/40	0
15/16	0	11	3	41 – 42	11
		12 – 14	0	42A/42B	11
Chapter 25		15 – 22	14	43 – 48	0
1/2	0	23 – 28	18	49 – 51	11
3 – 7	0	29 – 44	14	52	15
8	3			53 – 54	11
9 – 10	0	VOLUME 5		55/56	11
		Cover	15		
Chapter 26		Title	15	Chapter 53	
1 – 2	15	PN	15	1/2	11
3/4	0			3 – 20	11
5	11	Chapter 30			
6 – 11	0	1/2	11	VOLUME 6	
12	11	3/4	11	Cover	18
13	15	5	11	Title	18
14	18	6 – 7	15	PN	18
15 – 22	15	8 – 10	11		
				Chapter 62	
VOLUME 4		Chapter 32		1 – 2	14
Cover	18	1 – 2	11	3 – 16	9
Title	18	3/4	11	17 – 28	14
PN	18	5/6	11	29	9
		7 – 10	12	30	15
Chapter 28		11 – 21	11	31 – 34	9
1 – 2	11	22	12	35 – 36	14
3/4	16	23 – 36	11	37	9
5/6	0	37 – 38	12	38 – 39	14
7 – 10	0	39 – 54	11	40	9



LOG OF PAGES (CONT)

Page No.	Rev No.	Page No.	Rev No.	Page No.	Rev No.
41.....	14	VOLUME 7		35.....	0
42.....	9	Cover	19	36.....	15
43 – 46.....	14	Title	19	37.....	3
Chapter 63		PN.....	18	38.....	0
1 – 4.....	11	Chapter 64		39 – 40.....	15
4A – 4D.....	11	1 – 2.....	19	40A/40B.....	15
5 – 14.....	5	3/4.....	14	41 – 42.....	3
15.....	11	5/6.....	14	43.....	0
16 – 18.....	5	7 – 10.....	14	44.....	3
19 – 20.....	11	11.....	15	VOLUME 8	
21.....	14	12 – 14.....	16	Cover	18
22.....	11	15.....	14	Title.....	18
22A/22B.....	11	16.....	16	PN.....	18
23 – 24.....	11	17 – 22.....	19	Chapter 67	
25.....	15	23/24.....	19	1.....	14
26.....	11	25 – 38.....	19	2.....	11
27/28.....	5	39/40.....	19	3/4.....	18
29.....	5	41 – 52.....	19	5/6.....	0
30.....	11	Chapter 65		7.....	14
31 – 37.....	5	1.....	15	8 – 10.....	0
38 – 41.....	11	2.....	18	11 – 12.....	11
42.....	5	3/4.....	18	13.....	12
43/44.....	5	5.....	14	14 – 20.....	11
45 – 56.....	5	6.....	0	20A – 20B.....	11
57 – 59.....	18	7.....	5	20C/20D.....	11
60 – 78.....	5	8.....	14	21.....	0
79.....	11	9.....	18	22.....	3
80 – 89.....	5	10 – 11.....	0	22A – 22B.....	3
90.....	11	12.....	5	22C/22D.....	3
91/92.....	5	12A – 12B.....	18	23 – 24.....	0
93 – 94.....	5	13 – 14.....	18	25 – 26.....	14
95/96.....	5	15.....	14	26A/26B.....	14
97 – 100.....	5	16.....	18	27.....	15
101 – 105.....	11	16A – 16D.....	18	28.....	0
106 – 124.....	5	17.....	3	29 – 30.....	18
125 – 126.....	11	18 – 22.....	18	30A – 30B.....	18
127 – 129.....	14	22A – 22B.....	18	31 – 32.....	0
130 – 136.....	11	23 – 24.....	18	33/34.....	0
137/138.....	11	24A/24B.....	15	35 – 38.....	0
139/140.....	11	25 – 26.....	3	39.....	11
141 – 146.....	11	27.....	15	40.....	12
147.....	14	28.....	3	41.....	0
148 – 153.....	11	29.....	15	42.....	11
154 – 155.....	14	30.....	5	43/44.....	11
156.....	11	31.....	3	45 – 48.....	0
157/158.....	14	32.....	0	49/50.....	0
		33 – 34.....	3	51 – 54.....	15



LOG OF PAGES (CONT)

Page No.	Rev No.	Page No.	Rev No.	Page No.	Rev No.
55	11	2	11	65 – 73	0
56	5	3/4	8	74 – 75	11
57/58	11	5 – 10	8	76	14
VOLUME 9		11	13	76A/76B	14
Cover	18	12 – 15	8	77	0
Title	18	16	14	78 – 79	11
PN	18	17 – 18	8	80	0
Chapter 71		19	14	81	11
1	14	20 – 23	8	82 – 83	0
2 – 4	12	24	13	84 – 85	3
4A/4B	12	24A	13	86 – 90	11
5	0	24B – 24C	11	91	14
6	14	24D	13	92 – 94	11
6A/6B	14	24E/24F	13	95/96	11
7 – 10	0	25 – 32	8	97 – 100	11
11/12	0	33	13	101/102	11
13 – 36	0	34 – 35	8	103 – 104	0
37/38	0	36	12	105/106	0
39	12	37	13	107 – 109	0
40	11	38 – 51	8	110	3
41	0	52	13	111 – 117	0
42	11	53 – 58	8	118 – 125	11
42A – 42D	12	Chapter 79		126 – 132	0
43	11	1/2	0	133/134	0
44	5	3 – 5	0	135 – 138	0
45	0	6	11	139	5
46	11	7 – 18	0	140 – 142	0
47 – 72	0	VOLUME 10		143 – 145	11
73 – 80	11	Cover	18	146 – 147	0
80A	18	Title	18	148 – 149	11
80B	11	PN	18	150 – 176	3
80C/80D	11	Chapter 95		177 – 178	0
81 – 82	11	1 – 2	0	179/180	0
83 – 97	0	3/4	0	VOLUME 11	
98 – 99	12	5 – 8	0	Cover	14
100	11	9/10	0	Title	14
101 – 103	0	11 – 26	0	PN	14
104	11	Chapter 96		Chapter 97	
105 – 107	0	1 – 5	12	1 – 4	0
108	11	6	18	5/6	0
108A/108B	11	7 – 8	12	7 – 58	0
109	11	9/10	12	59	3
110 – 112	0	11 – 64	12	60 – 104	0
113/114	0	64A – 64F	12	105/106	0
Chapter 76		64G/64H	12	107 – 108	0
1	13	Chapter 97		109/110	0
		1 – 2	0	111 – 123	0
		3/4	0		
		5 – 8	0		
		9/10	0		
		11 – 26	0		
		Chapter 96			
		1 – 5	12		
		6	18		
		7 – 8	12		
		9/10	12		
		11 – 64	12		
		64A – 64F	12		
		64G/64H	12		



LOG OF PAGES (CONT)

Page No.	Rev No.	Page No.	Rev No.	Page No.	Rev No.
124 – 128.....	14	Chapter 98		51.....	5
129 – 158.....	0	1 – 35	0	52 – 58.....	0
159/160.....	0	36	15	59.....	5
VOLUME 12		37 – 39	0	60 – 176.....	0
Cover	15	40	15	177/178.....	0
Title	15	41 – 48	0		
PN.....	15	49	14		
		50	0		

H ELP

E VALUATE

L OGISTICS

P UBLICATIONS

Have you found something wrong with this manual — an error, an inconsistency, unclear instructions, etc.? Although we strive for accuracy and clarity, we may make errors on occasion. If we do and you discover it, we would appreciate your telling us about it so that we can change whatever is incorrect or unclear. Please be as specific as possible.

Your complaint or suggestion will be acknowledged and we will tell you what we intend to do.

You may use the enclosed Customer Feedback form, as applicable, to inform us where we have erred.

Your assistance is sincerely appreciated.



CUSTOMER FEEDBACK

RETURN VIA FAX TO PRODUCT SUPPORT ENGINEERING (450) 433-0272

Manual Title: _____

Manual Number (if assigned): _____

Date of Issue: _____

Date of Last Revision: _____

Section, Chapter, Paragraph Affected: _____

Your Feedback: _____

Now Reads: _____

Should Read: _____

Your Name: _____

Address: _____

Position: _____ **Telephone No.:** _____

Company: _____ **Fax No.:** _____

Reference No. (your initials and date): _____

(If you choose to mail this form, fold in thirds with address exposed, tape and mail.)

TAPE HERE

From _____

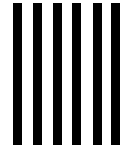

POSTAGE
NECESSARY

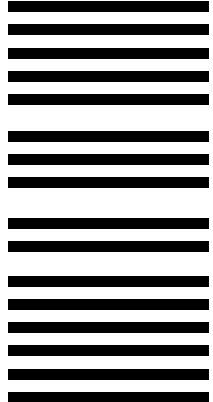

Product Support Engineering
12,800 rue de l'Avenir
Mirabel, Québec, Canada, J7J 1R4

FOLD ON DOTTED LINES AND TAPE

TAPE HERE

Export Classification C, ECCN EAR99



IMPORTANT
HELICOPTER SALES NOTICE

Please complete this form and return by mail, e-mail (publications@bellflight.com), or fax (817-280-6466, Attention: CPDC). This will ensure that the new owners/operators receive updates to their **Bell Textron Technical Manuals** and **Bulletins**.

Model of Helicopter Sold or Purchased _____

Serial and Registration Number _____

Name of **New Owner** (company or individual) _____

Name of **New Operator** _____

Future Publications to be mailed to this address:

Address _____

City _____

State/Province _____

Zip/Postal Code _____

Country _____

Fax No. _____ Telephone No. _____

E-mail Address _____

Register for access to electronic publications at www.mybell.com

TAPE HERE

From _____

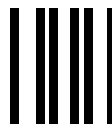

NO POSTAGE
NECESSARY
IF MAILED
IN THE
UNITED STATES

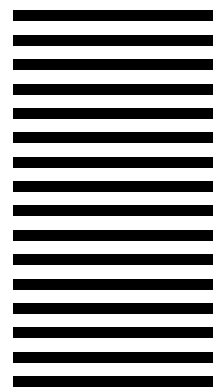

BUSINESS REPLY MAIL
FIRST CLASS PERMIT NO. 1744 FORT WORTH, TEXAS



**COMMERCIAL PUBLICATION DISTRIBUTION CENTER
P.O. BOX 482
FORT WORTH, TEXAS 76101-0482**

FOLD ON DOTTED LINES AND TAPE

TAPE HERE

Export Classification C, ECCN EAR99



SPARE PARTS WARRANTY

WARRANTY: Seller warrants each new helicopter part or helicopter part reconditioned by Seller to be free from defect in material and workmanship under normal use and service and if installed on Bell model helicopters for up to 1000 hours of operation, one (1) year from date of installation, or two (2) years from date of shipment by Seller, whichever occurs first. Seller assigns each manufacturer's warranty to Buyer to the extent such manufacturer's warranty exists and is assignable.

Parts, components and assemblies of all helicopter parts may have been restored or reworked due to marks, blemishes, dents or other irregularities during the manufacturing process. Such restoration and/or rework are permitted under Seller's approved manufacturing and engineering processes and guidelines. The restoration and/or rework so completed do not render such items defective in material or workmanship.

Seller's sole obligation under this warranty is limited to the repair or replacement of parts which are determined to Seller's reasonable satisfaction to have been defective within the applicable warranty period as described above. Replacement of parts may be either new or reconditioned at Seller's election and at the lowest allowable maintenance level contained in Seller's manuals, service bulletins or applicable supplier manuals. Seller shall also reimburse reasonable freight charges, excluding insurance, customs fees, duties, handling fees, and taxes. Seller shall not reimburse Buyer for any parts repaired or replaced outside of the Seller's Warranty Claims Process unless express prior written authorization is granted by Seller's Warranty Department to Buyer for such repair or replacement.

NO FAULT FOUND: In the event Seller determines, after evaluation of a returned part, that a defect does not exist, then Buyer shall pay all expenses incurred by Seller related to the return including, but not limited to, costs incurred in shipping and evaluating the part and cost for any replacement part and restocking of the part. In addition, Seller shall not reimburse Buyer for any costs related to the removal or reinstallation of such a part.

WARRANTY CLAIM PROCESS: Defective parts must be reported in writing to the Seller's Warranty Administration within fourteen (14) days of being found defective. Parts may be repaired or replaced with new or reconditioned parts, at Seller's election. Warranty adjustment is contingent upon the Buyer complying with the Seller's Warranty Process as described in the Bell Helicopter VISTA Customer Portal and with the Seller's Warranty Administration disposition instructions for defective parts. Failure to properly comply with Seller's Warranty Process may, at Seller's sole option, void Seller's warranty as to the allegedly defective part.

RETURN SHIPMENT: Parts returned to Seller will be eligible for remedy under this warranty only if the part is carefully packed by the Buyer for the return shipment. Damage occurring to a part due to improper packaging may result in the denial of a warranty claim. In the event that Seller determines a returned part to be damaged or unsalvageable due to improper packaging, the Buyer will be billed repair or replacement cost incurred by Seller. The party initiating shipment bears the risk of loss or damage to parts in transit.



CORE RETURNS: Any core removed by Buyer for which Seller has furnished a replacement part through the Warranty Process shall be shipped by Buyer, with all historical service records, to a facility designated by Seller, within fourteen (14) days of receipt by Buyer of the replacement part. Buyer shall provide Seller with proof of shipment within fourteen (14) days following receipt of the replacement part. In the event that Buyer fails to provide Seller with such proof of shipment within the fourteen (14) days or fails to provide the applicable historical service records, Buyer shall be charged the invoiced value of the replacement part.

WARRANTY AND LIABILITY DISCLAIMERS AND EXCLUSIONS: THIS WARRANTY IS GIVEN AND ACCEPTED IN PLACE OF (i) ALL OTHER WARRANTIES OR CONDITIONS, EXPRESS OR IMPLIED, INCLUDING BUT NOT LIMITED TO THE IMPLIED WARRANTIES OR CONDITIONS OF MERCHANTABILITY OR FITNESS FOR A PARTICULAR PURPOSE AND (ii) ANY OBLIGATION, LIABILITY, RIGHT, CLAIM OR REMEDY IN CONTRACT OR IN TORT, INCLUDING PRODUCT LIABILITIES BASED UPON STRICT LIABILITY, NEGLIGENCE, OR IMPLIED WARRANTY IN LAW.

This warranty is the only warranty made by Seller. The Buyer's sole remedy for a breach of this warranty or any defect in a part is the repair or replacement of the helicopter part and reimbursement of reasonable freight charges. Seller excludes liability, whether as a result of a breach of contract or warranty, negligence or strict product liability, for incidental or consequential damages, including without limitation, damage to the helicopter or other property, costs and expenses resulting from required changes or modifications to helicopter components and assemblies, changes in retirement lives and overhaul periods, local customs fees and taxes, and costs or expenses for commercial losses or lost profits due to loss of use or grounding of helicopters or otherwise.

Seller makes no warranty and disclaims all liability in contract or in tort, including, without limitation, negligence and strict tort liability, with respect to work performed by third parties at Buyer's request and with respect to engines, engine accessories, batteries, radios, and avionics.

Seller makes no warranty and disclaims all liability with respect to components or parts damaged by, or worn due to, normal wear and tear, erosion or corrosion. Seller makes no warranty and disclaims all liability for consumables which are defined as items required for normal and routine maintenance or replaced at scheduled intervals shorter than the warranty period. "Consumables" include but are not limited to engine and hydraulic oil, oil filters, packings and o-rings, anti-corrosion and/or sealing compounds, brush plating material, nuts, bolts, washers, screws, fluids, compounds, and standard aircraft hardware that is readily available to aircraft operators from sources other than Seller.

This warranty shall not apply to any helicopter part which has been repaired or altered outside Seller's factory in any way so as, in Seller's sole judgment, to affect its stability, safety or reliability. This warranty shall not apply to any helicopter part which has been subject to misuse, negligence or accident, or which has been installed in any aircraft which has been destroyed. Repairs and alterations which use or incorporate parts and components other than genuine Bell parts or parts approved by Bell for direct acquisition from sources other than Bell itself are not warranted by Bell, and this warranty shall be void to the extent that such repairs and alterations,



in Seller's sole judgment, affect the stability, safety or reliability of the helicopter or any part thereof, or damage genuine Bell or Bell-approved parts. No person, corporation or organization, including Bell Authorized Customer Service Facilities, is authorized by Seller to assume for it any other liability in connection with the sale of its helicopters and parts.

NO STATEMENT, WHETHER WRITTEN OR ORAL, MADE BY ANY PERSON, CORPORATION OR ORGANIZATION, INCLUDING BELL AUTHORIZED CUSTOMER SERVICE FACILITIES, MAY BE TAKEN AS A WARRANTY NOR WILL IT BIND SELLER.

CHOICE OF LAW AND JURISDICTION: This warranty shall be interpreted under and governed by the laws of the State of Texas. All legal actions based upon claims or disputes pertaining to or involving this warranty including, but not limited to, Seller's denial of any claim or portion thereof under this warranty, must be filed in the courts of general jurisdiction of Tarrant County, Texas or in the United States District Court for the Northern District of Texas, Ft. Worth Division located in Ft. Worth, Tarrant County, Texas. In the event that Buyer files such an action in either of the court systems identified above, and a final judgment in Seller's favor is rendered by such court, then Buyer shall indemnify Seller for all costs, expenses and attorneys' fees incurred by Seller in defense of such claims. In the event Buyer files such a legal action in a court other than those specified, and Seller successfully obtains dismissal of that action or transfer thereof to the above described court systems, then Buyer shall indemnify Seller for all costs, expenses and attorneys' fees incurred by Seller in obtaining such dismissal or transfer.



BULLETIN RECORD

All Alert Service Bulletins (ASB) and Technical Bulletins (TB) issued prior to and including the bulletins listed below have been incorporated in this revision/reissue or previously published editions of this manual, as applicable. Subsequent bulletins will be incorporated in future revisions/reissues.

ALERT SERVICE BULLETINS

ASB NUMBER	SUBJECT	DATE
 212-20-162	Tailboom Left Hand Fin Spar Cap P/N 212-030-447-117, Inspection of.	15 April 2020

 This bulletin and all previously issued applicable bulletins have been incorporated, except the ASB 212-00-106 is not incorporated.

TECHNICAL BULLETINS

TB NUMBER	SUBJECT	DATE
212-95-156	Pillow Block Bushing 204-011-135-105 Increase in Retirement Life	18 September 1995



TEMPORARY REVISION RECORD

This Temporary Revision Record provides a current listing of active Temporary Revisions against the manual. Temporary Revisions, which have been canceled/incorporated, will only be maintained on the record until the next revision is issued. If there are no Temporary Revisions shown on the record, this is confirmation that there are no Temporary Revisions issued against the manual.

TEMP. REV. NO.	TITLE	DATE ISSUED	DATE CANCELED
----------------	-------	-------------	---------------

NOTE: For tracking purposes, Temporary Revisions are now being numbered (Example: TR-1).



LIST OF CHAPTERS

Title	Chapter
Introduction	1
Airworthiness Limitations Schedule	4
Inspections	5
Dimensions and Charts	6
Lifting and Jacking	7
Weight and Balance	8
Towing	9
Parking and Mooring	10
Placards and Markings	11
Servicing	12
Vibration and Noise Analysis	18
Air Distribution (Ventilation)	21
Equipment and Furnishings	25
Fire Protection	26
Fuel System	28
Hydraulic System	29
Ice and Rain Protection	30
Landing Gear	32
Doors and Windows	52
Fuselage	53
Main Rotor	62
Main Rotor Drive System	63
Tail Rotor	64
Tail Rotor Drive System	65
Flight Controls	67
Power Plant	71
Engine Controls	76
Engine Oil System	79
Instrument System	95
Electrical System	96
Avionics	97
Wiring Diagrams	98

CHAPTER 1 — INTRODUCTION

CONTENTS — MAINTENANCE PROCEDURES

Paragraph Number	Title	Chapter/Section Number	Page Number
1-1	General	1-00-00	3/4
THE MANUAL			
1-2	Use of the manual	1-00-00	5
1-3	Bulletins	1-00-00	5
1-4	Consumable materials	1-00-00	5
1-5	Special tools	1-00-00	5
1-6	Torques	1-00-00	5
1-7	Terminology	1-00-00	5
1-8	Warnings, cautions, and notes	1-00-00	5
1-9	Use of procedural words	1-00-00	6
1-10	Wear limits	1-00-00	6
1-11	Standard practices	1-00-00	6
1-12	Replacement parts and assemblies	1-00-00	6

THE HELICOPTER

1-13	Description of helicopter	1-00-00	7
------	---------------------------------	---------	---

FIGURES

Figure Number	Title	Page Number
1-1	Model 212 helicopter (typical)	8

INTRODUCTION

1-1. GENERAL.

This Chapter provides a general description of the contents and use of this maintenance manual and the Model 212 Helicopter.

Generally, maintenance procedures for components or assemblies which have been removed from the helicopter are contained in BHT-212-CR&O Component Repair and Overhaul Manual.

THE MANUAL

1-2. USE OF THE MANUAL.

This manual is divided into Volumes, subdivided by Chapters. To find a desired subject, refer to the Alphabetical Index located within this Chapter to obtain the Chapter containing the desired information. Refer to the desired Volume and using the tabbed pages provided which separate each Chapter, refer to the Table of Contents at the beginning of the desired Chapter to locate the specific subject.

1-3. BULLETINS.

As necessary, Technical Bulletins (T.B.s) and Alert Service Bulletins (A.S.B.s) will be issued. These documents provide information to modify components or systems on the helicopter. Refer to Bulletin Record, BR-1/2 preceding this Chapter for bulletins which have been incorporated in this manual. Additional space is provided for listing T.B.s and A.S.B.s which are incorporated by the owner/operator.

Compliance with all alert service bulletins is mandatory.

1-4. CONSUMABLE MATERIALS.

WARNING

HANDLING AND STORAGE OF CONSUMABLE MATERIALS SHALL BE IN ACCORDANCE WITH MANUFACTURER'S INSTRUCTIONS UNLESS OTHERWISE NOTED IN APPLICABLE MAINTENANCE TASKS.

Consumable materials required while performing maintenance are listed in the text by name and an item number such as "solvent (C-304)". The number refers to item 304 in Chapter 13 of BHT-ALL-SPM, Standard Practices Manual. In addition, a list of all consumable materials (by item number

and full nomenclature) required for each individual Chapter is provided following the Table of Contents for that Chapter.

Occasionally, materials used in maintenance change properties, suppliers, or are discontinued. Also, new and more advanced materials become available. In the event of conflict between this manual and the Standard Practices manual, the manual with the latest date of issue lists the preferred material. However, either material may be used for the accomplishment of the prescribed task unless specifically stated otherwise.

1-5. SPECIAL TOOLS.

Certain maintenance procedures require the use of special tools. Special tools required are listed at the beginning of the applicable maintenance paragraph. A complete description and illustration of these tools is provided in BHT-TOOL-IPC.

1-6. TORQUES.

Torques are specified as either standard or special within this manual. Standard torque values for various type fasteners will be found in BHT-ALL-SPM. Where applicable, special torques are specified within the text (or on illustrations) within this manual.

1-7. TERMINOLOGY.

1-8. WARNINGS, CAUTIONS, AND NOTES.

Warnings, cautions, and notes are used throughout this manual to emphasize important and critical instructions as follows:

WARNING

AN OPERATING PROCEDURE, PRACTICE, ETC., WHICH, IF NOT

CORRECTLY FOLLOWED, COULD RESULT IN PERSONAL INJURY OR LOSS OF LIFE.



AN OPERATING PROCEDURE, PRACTICE, ETC., WHICH, IF NOT STRICTLY OBSERVED, COULD RESULT IN DAMAGE TO, OR DESTRUCTION OF, EQUIPMENT.

NOTE

An operating procedure, condition, etc., which is essential to highlight.

1-9. USE OF PROCEDURAL WORDS.

The concept of procedural word usage and intended meaning which is used throughout this manual is as follows:

'Shall' is used only when application of a procedure is mandatory.

'Should' is used only when application of a procedure is recommended.

'May' and 'need not' is used only when application of a procedure is optional.

'Will' is used only to indicate futurity, never to indicate a mandatory procedure.

1-10. WEAR LIMITS.



METRIC EQUIVALENTS TO U.S. STANDARD WEIGHTS AND

MEASURES ARE PROVIDED THROUGHOUT THIS MANUAL. WHILE PERFORMING MEASUREMENTS TO DETERMINE THE SERVICEABILITY OF A COMPONENT OR TO ESTABLISH A SPECIFIED DIMENSION, ONLY THE U.S. STANDARD VALUES SHALL BE USED.

Throughout this manual, wear limits are provided to show the required fit between mating parts. It is not intended that all dimensions be checked as a prescribed maintenance procedure; however, parts that show evidence of wear or physical damage must be checked dimensionally.

Wear limits, fit, and tolerances are integrated into the inspection, repair, and assembly procedures. Unless otherwise specified, dimensions shall carry the following tolerances on decimals.

DECIMAL	TOLERANCE
.XXX	±0.010 inch
.XX	±0.03 inch
.X	±0.1 inch

1-11. STANDARD PRACTICES.

Standard maintenance practices and procedures not specifically described within this manual are contained in BHT-ALL-SPM.

1-12. REPLACEMENT PARTS AND ASSEMBLIES.

Replacement parts and assemblies required for proper maintenance are listed in a companion Illustrated Parts Catalog. This catalog provides complete nomenclatures, part numbers, and ordering information.

THE HELICOPTER

1-13. DESCRIPTION OF HELICOPTER.

The Model 212 helicopter (figure 1-1) consists of two major assemblies: The forward fuselage and the tailboom. The forward fuselage is of semimonocoque and reinforced shell construction with transverse bulkheads and metal and fiberglass covering. Two longitudinal main beams provide the primary structural support.

A hinged door on either side of the forward area permits direct access to the crew area and a large sliding door permits access to the cargo/passenger area. Additionally, a hinged cargo door is located immediately ahead of the sliding door. This door increases the width of access to the cargo/passenger area. Seating is provided for the pilot and forward passenger/copilot in the crew area (cockpit) and up to 13 passengers in the cargo/passenger (cabin) area.

The engine deck, located above and aft of the passenger/cargo area, is designed to accommodate the engine, reduction (combining) gearbox, firewalls, and air management system.

The tailboom is of semimonocoque construction which provides support for a vertical fin, aerodynamically actuated elevator, tail rotor and tail rotor drive system, tail skid, and baggage compartment.

The powerplant is a Pratt and Whitney of Canada, Ltd. PT6T-3 or PT6T-3B twin turboshaft (Twin-Pac) engine consisting of two identical free turbine power sections. A common reduction (combining) gearbox mounted across the aft end of the power sections has an engine-to-transmission output shaft (main driveshaft) extending forward along the centerline of the engine to provide power to the transmission.

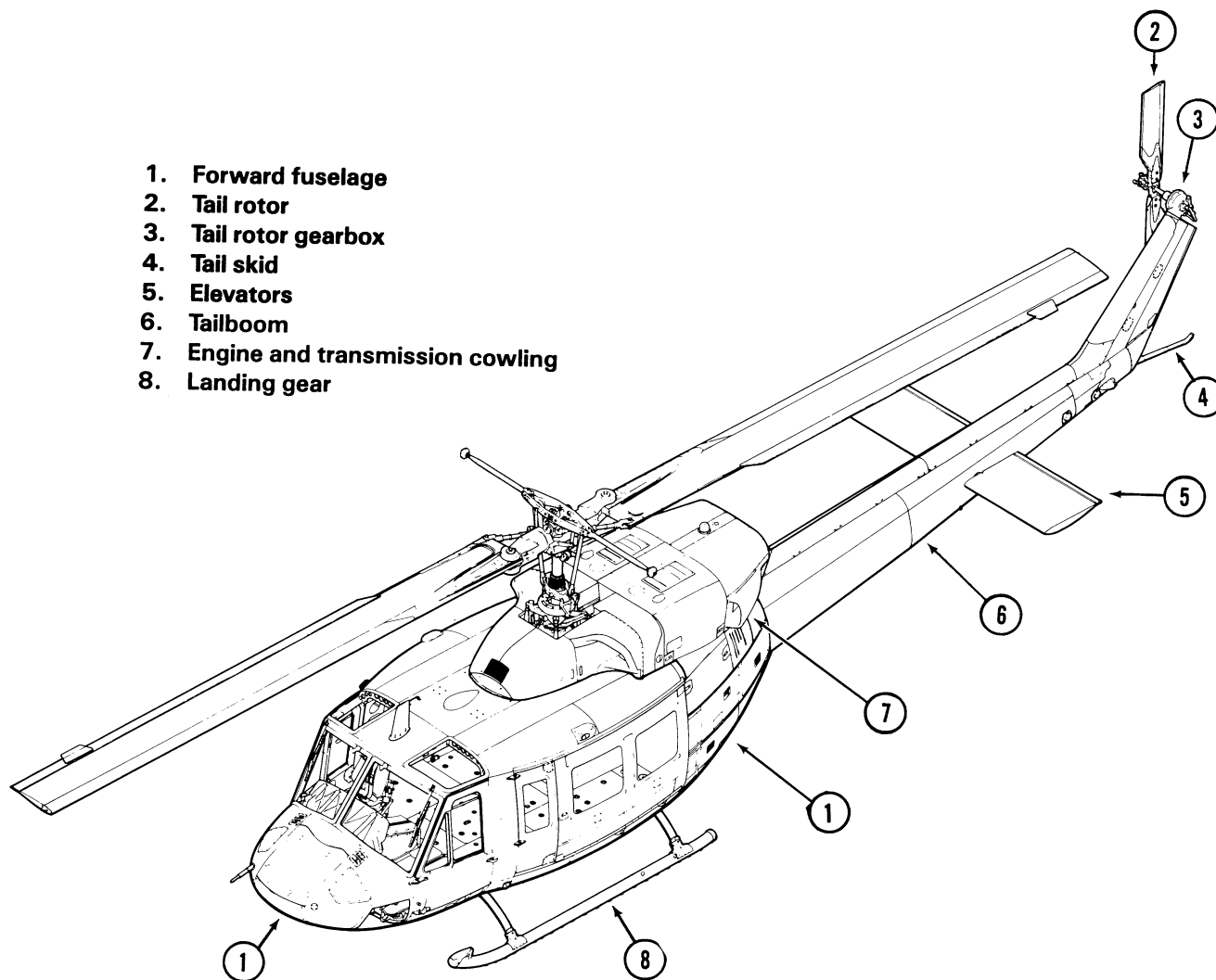

212-M-1-1

Figure 1-1. Model 212 helicopter (typical)



CHAPTER 4 — AIRWORTHINESS LIMITATIONS SCHEDULE

TABLE OF CONTENTS

Paragraph Number	Title	Chapter/Section Number	Page Number
AIRWORTHINESS LIMITATIONS SCHEDULE			
4-1	Airworthiness limitations schedule	4-00-00	5
4-2	Calculating flight hours on 204-011-102 yoke	4-00-00	12

TABLES

Table Number	Title	Page Number
4-1	Mandatory Airworthiness Limitations Schedule	6



REVISION NO.	DATE OF SIGNATURE	FAA/ODA* SIGNATURE
Reissue	7 June	NOT EFFECTED
Revision 1	14 October 1994	NOT EFFECTED
Revision 2	3 February 1995	NOT EFFECTED
Revision 3	1 August 1995	NOT EFFECTED
Revision 4	1 May 1996	NOT EFFECTED
Revision 5	25 September 1997	
Revision 6	N/A	N/A
Revision 7	N/A	N/A
Revision 8	N/A	N/A
Revision 9	N/A	N/A
Revision 10	N/A	N/A
Revision 11	N/A	N/A
Revision 12	N/A	N/A



REVISION NO.	DATE OF SIGNATURE	FAA/ODA* SIGNATURE
Revision 13	N/A	N/A
Revision 14	N/A	N/A
Revision 15	N/A	N/A
Revision 16	N/A	N/A
Revision 17	N/A	N/A
Revision 18	N/A	N/A
Revision 19	15 JULY 2021	SARAH F COX  Digitally signed by SARAH F COX Date: 2021.07.15 08:48:16 -05'00'



AIRWORTHINESS LIMITATIONS SCHEDULE

4-1. AIRWORTHINESS LIMITATIONS SCHEDULE

The mandatory Airworthiness Limitations Schedule summarizes, in tabular form, the mandatory maximum life, in hours, years or by Retirement Index Number (RIN) of components with a limited airworthiness life. Parts that are not on the schedule have an unlimited airworthiness life.

NOTE

The Airworthiness Limitations section is FAA approved and specifies maintenance required under Secs. 43.16 and [91.403] of the Federal Aviation Regulations unless an alternative program has been FAA approved.

Refer to United Aircraft of Canada Ltd. Service Bulletins, 5000 series, for power plant components Airworthiness Limitations.

CAUTION

AIRWORTHINESS LIFE FOR KIT COMPONENT AND/OR PARTS ARE NOT COVERED IN THIS AIRWORTHINESS SCHEDULE. REFER TO APPLICABLE SERVICE INSTRUCTIONS FOR MANDATORY AIRWORTHINESS SCHEDULE.

NOTE

The operating time specified for retirement for any given part number contained in this Airworthiness Limitations Schedule applies to all successive dash numbers for that item unless otherwise specified.

Airworthiness lives assigned to helicopter components and assemblies are based upon experience, testing, and engineering judgment and are subject to change at the sole discretion of Bell Textron or an appropriate government agency.

















WARNING

ALL PARTS REMOVED DUE TO REACHING THEIR LIFE LIMITS ARE DEEMED UNAIRWORTHY AND SHALL BE PERMANENTLY MARKED AS SCRAP OR PHYSICALLY DESTROYED TO THE EXTENT THAT THERE IS NO CHANCE OF REPAIR OR REINSTALLATION ON ANY HELICOPTER OR COMPONENT.





NOTE

Neither assignment of a retirement life to a component, nor failure to assign a retirement life, constitutes a warranty of any kind. The only warranty applicable to the helicopter and any component is that warranty included in the Purchase Agreement for the helicopter or the component.

Mandatory airworthiness limitations schedule

COMPONENT	PART NUMBER 	AIRWORTHINESS LIFE
MAIN ROTOR BLADE AND HUB ASSEMBLY		
Blade	204-012-001-023	1500 Hours
Blade	204-012-001-031	4000 Hours
Blade	204-012-001-033	1500/4000 Hours 
Blade	212-015-501-005 and -115	4000 Hours
Retention Strap	204-012-122-001, -005 and 204-310-101-101	1200 Hours or 2 years, whichever occurs first. 
Outboard Strap Fitting	204-012-103-005	3600 Hours
Inboard Strap Fitting	212-010-103-005	1200 Hours 
Inboard Strap Fitting	212-010-103-007	2400 Hours
Strap Pin	204-012-104-003	2400 Hours
Main Rotor Yoke	204-011-102-(All)	3600 Hours 
Main Rotor Yoke	212-011-102-105	10,000 Hours 
Main Rotor Yoke	212-011-102-109	6000 Hours 
Pillow Block	204-011-108-113	Conditional 
Pillow Block Bushing	204-011-135-003	2400 Hours
Pillow Block Bushing	204-011-135-105	3600 Hours
Main Rotor Mast	204-011-450-007 and -105	15,000 Hours or RIN = 300000; whichever occurs first.   
Main Rotor Mast	204-011-450-113	13,000 Hours or RIN=275000; whichever occurs first.  
Main Rotor Mast	204-011-450-119	13,000 Hours or RIN=275000; whichever occurs first.  
Main Rotor Trunnion	204-011-105-103	13,000 Hours or RIN=275000; whichever occurs first.  

Mandatory airworthiness limitations schedule (Cont)

COMPONENT	PART NUMBER 	AIRWORTHINESS LIFE
Main Rotor Trunnion	204-011-105-001	15,000 Hours or RIN = 300000; whichever occurs first.   
MAIN ROTORS CONTROLS		
Pitch Horn	204-011-120-005	3000 Hours
Swashplate Drive Link	204-011-407-001	9000 Hours
Swashplate Outer Ring	204-011-403-001	9000 Hours
Swashplate Support	204-011-404-009	1000 Hours
Swashplate Support	204-011-404-121 and -125	1000 Hours
Stabilizer Bar Centerframe	204-011-307-001 and -105	10,000 Hours
Stabilizer Bar Tube	204-011-328-001	2400 Hours or 3 years; whichever occurs first.
Stabilizer Bar Tube	204-011-328-011	5000 Hours or 5 years; whichever occurs first.
Mixing Lever	204-011-301-001	9000 Hours
Mixing Lever	212-010-302-001 and -105	9000 Hours
Mixing Lever Pivot Bearing	MS27641-6 	100 Hours
Gimbal Ring	204-010-404-001	9000 Hours
Scissors Hub	204-011-405-013	9000 Hours
Scissors Single Pivot Bearing	MS20201KP8A 	100 Hours
Scissors Tube	212-010-404-005	9000 Hours
Pitch Link	204-011-127-001 and -003	9000 Hours
Collective Sleeve	204-011-408-003, -105 and -107	9000 Hours
TAIL ROTOR AND CONTROLS		
Yoke (Hog-out)	212-010-704-001, -005 and -107	5000 Hours
Yoke (Forging)	212-010-744-001, -005 and -107	5000 Hours



Mandatory Airworthiness Limitations Schedule (Cont)

COMPONENT	PART NUMBER 	AIRWORTHINESS LIFE
Yoke	212-011-702-001	5000 Hours
Blade	212-010-750-009 and -105	5000 Hours
Blade Assembly	412-016-100-111	5000 Hours

POWER TRAIN DRIVE SYSTEM COMPONENTS

Spider	204-040-785-003	Conditional 
Spider	412-040-785-101	2500 
Spider	412-040-785-103	Unlimited
Mast Bearing	204-040-136-009	1000 Hours
Bearing (When used in rotor brake quill)	204-040-424	600 Hours 
Tail Rotor Hanger Bearing	204-040-623-001	100 Hours
Tail Rotor Hanger Bearing	204-040-623-005	1000 Hours
Pinion — Offset Accessory Drive	212-040-202-001	1000 Hours





POWER PLANT RELATED SYSTEMS

Blower, Oil Cooler	212AA3192 (Benson)	300 Hours
--------------------	--------------------	-----------

LANDING GEAR

Crosstubes	205-050-400-007, -029, -035 and -705	1000 Hours 
------------	--------------------------------------	--







FLOAT LANDING GEAR (KIT P/N 205-706-050-001, -007, -011, -101)

Crosstube Assembly	205-050-114-001	500 Hours 
Crosstube Assembly	205-050-114-011	1000 Hours 
Crosstube Assembly	205-050-114-023, -025	Unlimited
Crosstube Assembly	205-706-050-005	500 Hours 
Crosstube Assembly	205-706-050-013	1000 Hours 
Crosstube Assembly	205-706-050-015	Unlimited



Mandatory airworthiness limitations schedule (Cont)

COMPONENT	PART NUMBER 	AIRWORTHINESS LIFE
CONTROL SYSTEM BOLTS (KIT P/N 212-704-092-001) 		
Swashplate Support to Collective Lever Pivot Bolts (2)	AN178-22A	1000 Hours
Pitch Horn to Pitch Link (2)	20-057-6-31D	1000 Hours
Pitch Link to Universal (2)	20-057-6-27D	1000 Hours
Universal to Mixing Lever (2)	20-057-6-34D	1000 Hours
Mixing Lever to Scissors Tube (2)	20-057-5-27D	1000 Hours
Scissors Tube to Scissors (2)	20-057-5-27D	1000 Hours
Scissors (204-011-406) Pivot Bolt (2)	20-057-8S90D or 20-057-8-86D	1000 Hours
Scissors (212-010-407) Pivot Bolt (2)	212-010-411-5 or -3	1000 Hours
Scissors to Drive Link (2)	20-057-8S69D	1000 Hours
Drive Link to Rotating Swashplate (2)	20-057-5-30D	1000 Hours
Fixed Swashplate to Right Cyclic Boost Tube (1)	20-057-5-24D	1000 Hours
Fixed Swashplate to Left Cyclic Boost Tube (1)	20-057-5-24D	1000 Hours
Collective Lever to Collective Boost Tube (1)	20-057-5-24D	1000 Hours
Hydraulic Cylinder Tube to Swashplate Universal (3)	20-057-5-24D	1000 Hours
Universal to Hydraulic Cylinder (3)	20-057-5-24D	1000 Hours
Hydraulic Cylinder to Lower Support (3)	212-001-304-003	1000 Hours
Hydraulic Cylinder to Lower Support (3)	212-001-323-001	2500 Hours
Gimbal to Inner Ring (2)	204-011-463-001	1000 Hours

Mandatory airworthiness limitations schedule (Cont)

COMPONENT	PART NUMBER 	AIRWORTHINESS LIFE
Gimbal to Swashplate Support (2)	204-011-463-003	1000 Hours
Stabilizer Bar Pivot Bolts (2)	20-057-10S27D or 20-057-10S29D	1000 Hours
Mixing Lever (204-011-301) Pivot Bolts (4)	20-057-6S20D or 20-057-6S23D	1000 Hours
Mixing Lever (212-010-302) Pivot Bolts (4)	20-057-6S23D or 20-057-6S24D	1000 Hours
MISCELLANEOUS		
Battery (Blade Inspection System)	MN1604 or 522	500 Hours or 6 Months; whichever occurs first.
Cartridge, Fire Extinguisher	209-062-908-13	6 Years 
Cartridge, Fire Extinguisher	209-062-908-17	6 Years 
Cartridge, Fire Extinguisher	209-062-908-15	4 Years In-Service Life (6 Years Total) 
Cartridge, Fire Extinguisher	209-062-908-19	4 Years In-Service Life (6 Years Total) 
Cartridge, Fire Extinguisher	209-062-908-109	6 Years 

NOTES:

-  All subsequent dash number changes have the same airworthiness life presented unless otherwise noted.
-  Rotor blades with serial numbers not listed as follows have a 1500 hour airworthiness limitation schedule. Rotor blades listed as follows have a 4000 hour airworthiness limitation schedule: AMR-04017 through AMR-04047, AMR-04053 through AMR-04074, AMR-54001, AMR-54002, AMR-54005, AMR-54006, AMR-54008 through AMR-54073, AMR-54097, and AMR-54099 through AMR-54256.
-  Repeat heavy lift operators must factor their flight time according to the following table for 212 main rotor yoke:













Number of events/hr*	Factor
1.0 — 5.0	1.0
5.1 — 8.0	1.5

Mandatory airworthiness limitations schedule (Cont)

COMPONENT	PART NUMBER 	AIRWORTHINESS LIFE
	8.1 — 12.0	2.0
	12.1 — 18.0	3.0
	18.1 — 32.0	5.0
	32.1 — 48.0	7.0
	48.1 — 62.0	9.0

*An event is a lift operation or takeoff.

*A logging lift counts as two events.

-  The airworthiness life for this bearing and any authorized replacement bearing is applicable if installed in 204-011-301 mixing lever.
-  The airworthiness life for this bearing and any authorized replacement bearing is applicable if installed in 204-011-406 scissors.
-  Inspect control system bolts each 24 months ([Chapter 5](#)).
-  Cartridge service/shelf life starts from date of manufacture.
-  All tension-torsion straps must be retired after 24 months calendar time in service. In this application, calendar time in service begins when new straps installed in main rotor hub and blade assembly are subjected to powered rotation.
-  Not authorized for use with Kit, 212-704-153-101.
-  Perform a dye penetrant inspection of pillow block every 2400 hours.
-  Perform magnetic particle inspection of spider every 3100 hours per ASB 212-91-66A.
-  Upon retirement of the 212-010-103-005 strap fitting, the -005 fitting shall be replaced with the 212-010-103-007 strap fitting.
-  Helicopters with T.B.212-91-138 incorporated shall not use stainless steel main rotor yoke assembly P/N 212-011-102-105.
-  Overhaul schedule for rotor brake quill is 2400 hours; however, the 204-040-424 bearing used in the 205-040-300 quill shall be replaced each 600 hours. The 222-342-420 bearing used in the 412-040-125 quill does not have a finite life.
-  Successive dash nos. (-103 and sub.) do not have a finite life.
-  Retirement Index Number (RIN) is the retirement life based on fatigue damage from normal helicopter lifts and takeoffs. New components will begin with an accumulated RIN of zero that will be increased as lifts and takeoffs are performed. Operators must record the number of lifts and takeoffs and increase the accumulated RIN accordingly.



Mandatory Airworthiness Limitations Schedule (Cont)

NOTES (CONT):

When the maximum RIN or retirement flight hours is reached, whichever occurs first, the component will be removed from service

17 Increase RIN count by 5 for each takeoff/lift performed. If logging, increase RIN count by 10 for each takeoff/lift performed. Logging is defined as – Repeated heavy lift events using an external long line which involve significant torque excursions (>80%) and elevation changes.

18 Per [ASB 212-80-18](#) and [ASB 212-76-3](#).

19 Per [ASB 212-77-17](#).

4-2. CALCULATING FLIGHT HOURS ON 204-011-102 YOKE.

Calculate flight hours on the yoke using the table given in note **3** to determine the correct factor based on the number of events per flight hour:

1. If flight hours cannot be determined, use the following:

Enter on yoke Historical Service Record 900 hours per year from date of helicopter delivery or date yoke was installed.

2. If number of lift events per hour cannot be determined, use the following:

Enter on yoke Historical Service Record five hours for each flight hour of external operation, or

two hours for each flight hour of internal operation for which the number of events cannot be determined. Use five hours for each flight hour if time actually spent in external or internal operation cannot be determined.

3. Perform the following operations following calculation or approximation of flight hours/lift events:

If main rotor yoke flight hours exceed 3300, remove yoke from service within the next 300 hours.

Retire main rotor yoke at 3600 hours.



CHAPTER 5 — INSPECTIONS

TABLE OF CONTENTS

Paragraph Number	Title	Chapter/Section Number	Page Number
INSPECTIONS			
5-1	General	5-00-00	5
5-2	Inspection Requirements	5-00-00	6
5-3	Crash Damage	5-00-00	6
5-4	Types of Inspections	5-00-00	6
5-5	Definitions	5-00-00	7
5-6	Inspection and Overhaul Tolerance	5-00-00	8
SCHEDULED INSPECTIONS			
5-7	Scheduled inspections	5-00-00	11
5-8	Daily Inspection — Part A	5-00-00	13
5-9	100 Hours/12 Calendar Months — Part A	5-00-00	29
5-10	1000 Hours — Part A	5-00-00	53
5-11	5000 Hours/5 Years Inspection — Part A	5-00-00	55
5-12	25 Hours/30 Days — Part B	5-00-00	61
5-13	300 Hours/12 Months Inspection — Part B	5-00-00	79
5-14	600 Hours/12 Months — Part B	5-00-00	91
5-15	5000 Hours/5 Years Inspection — Part B	5-00-00	99
SPECIAL INSPECTIONS			
5-16	Special Inspection	5-00-00	105
5-17	Daily Inspection	5-00-00	107
5-18	Daily or Each 10 Hours of Flight Operation, Whichever Occurs First Until 250 Hours	5-00-00	109
5-19	Between 5 and 10 Hours of Flight After Each Installation	5-00-00	115
5-20	Fin Spar Cap Inspection Every 8 Hours	5-00-00	117
5-21	Each 25 Hours for the next Four Inspections	5-00-00	119
5-22	Each 25 Hours of Flight Operation	5-00-00	121
5-23	Each Seven Days in a Corrosive Environment and Each 30 Days in a Noncorrosive Environment	5-00-00	127
5-24	50 Hours After Installation of Components	5-00-00	129
5-25	Each 50 Hours of Component Operation	5-00-00	131
5-26	Each 100 Hours of Main Rotor Blade Operation — Deleted	5-00-00	133
5-27	Each 100 Hours/12 Months of Transmission Operation	5-00-00	135
5-28	Each 100 Hours/12 Months of Intermediate Gearbox Operation ...	5-00-00	137
5-29	Each 100 Hours/12 Months of Tail Rotor Gearbox Operation	5-00-00	139
5-29A	Fin Spar Cap Inspection Every 100 Hours	5-00-00	140A
5-30	Each 100 Hours/12 Months of Battery System Operation	5-00-00	141
5-31	100 Hours After Installation of Tailboom	5-00-00	143
5-32	Each 150 Hours of Starter Generator P/N 200SG119Q Operation	5-00-00	145
5-33	Fin Spar Cap Inspection Every 300 Hours	5-00-00	147
5-34	Each 300 Hours/12 Months of Transmission Operation	5-00-00	149



TABLE OF CONTENTS (CONT)

Paragraph Number	Title	Chapter/Section Number	Page Number
5-35	Each 300 Hours/3 Months of Driveshaft Operation	5-00-00	151
5-35A	Each 300 Hours/12 Months Inspection of Tail Rotor Control Tube and Bearing	5-00-00	152A
5-36	Main Rotor Grip Ultrasonic Inspection	5-00-00	153
5-37	Each 500 Hours/6 Months of Blade Service	5-00-00	155
5-38	Each 600 Hours of Transmission Operation	5-00-00	157
5-39	600 Hours/12 Months of Tail Rotor Driveshaft Coupling Operation	5-00-00	159
5-40	600 Hours/12 Months of Main Driveshaft Operation.....	5-00-00	161
5-40A	Each 600 Hours/12 Months Inspection of Magnetic Brake Assembly	5-00-00	162A
5-40B	Each 600 Hours/12 Months Inspection of Fire Extinguisher Discharge Tubes.....	5-00-00	162C
5-41	Each 1000 Hours of Component Operation	5-00-00	163
5-42	First 1000 Hours of Component Time and Each 3000 Hours Thereafter of Component Time.....	5-00-00	165
5-43	Each 1000 Hours/12 Months of Main Rotor Blade Operation.....	5-00-00	169
5-44	Each 1200 Hours/24 Months of Component Operation	5-00-00	171
5-45	Each 1200 Hours of Main Rotor Hub Pin Operation — Deleted	5-00-00	175
5-45A	Every 12 months/2500 Landings High Forward Crosstube Deflection Check.....	5-00-00	176A
5-45B	Every 12 months/5000 Landings High Forward Crosstube Fluorescent Penetrant Inspection	5-00-00	176C
5-46	Each 24 Months of Flight Control System Bolt Operation.....	5-00-00	177
5-47	Each 3000 Hours of Component Operation.....	5-00-00	181
5-48	10,000 Hour Total Airframe Time and Each 300 Hours/12 Months Main Beam Cap Operation	5-00-00	187
5-48A	10 Years Collective Stick Tube Inspection.....	5-00-00	188A

CONDITIONAL INSPECTIONS

5-49	Condition Inspection	5-00-00	189
5-50	After Hard Landing.....	5-00-00	191
5-51	After Blade Strike or Other Rotating System Torque Spike	5-00-00	197
5-52	After Overspeed.....	5-00-00	205
5-53	After Overtorque	5-00-00	209
5-54	After Engine Compressor Stall or Surge.....	5-00-00	213
5-55	After Lightning Strikes.....	5-00-00	219
5-56	After Engine Combining Gearbox Clutch Nonengagement, Misengagement, or In-flight Slippage	5-00-00	227

COMPONENT OVERHAUL SCHEDULE

5-57	Component Overhaul Schedule.....	5-00-00	231
------	----------------------------------	---------	-----



FIGURES

Figure Number	Title	Page Number
5-1	Fuselage Tailboom Attachment Inspection.....	50
5-2	Inspection of Beam Caps.....	51
5-2A	Cabin Frame Inspection — Part A.....	60B
5-3	Cabin Frame Inspection — Part B.....	104B
5-4	Inspection of Main Rotor Hub Grip Tangs, Barrel and Drag Brace Attachment Lugs.....	108
5-5	Spiral Bevel Gears Serial Numbers.....	111
5-6	Inspection of Spiral Bevel Gear.....	112
5-6A	Tail Rotor Blade - Detailed Inspection.....	126B
5-6B	Spar Cap Inspection.....	140B
5-7	Inspection of Main Rotor Hub Grip (1200 Hours/24 Months).....	174
5-8	Collective Stick Tube.....	188B

TABLES

Table Number	Title	Page Number
5-1	Component Overhaul Schedule.....	231

INSPECTIONS

5-1. GENERAL

This chapter contains the requirements for the Scheduled, Special, and Conditional Inspections and a Component Overhaul Schedule.

WARNING

FAILURE TO CORRECT CONDITIONS SUCH AS, BUT NOT LIMITED TO, CORROSION, EROSION, MECHANICAL DAMAGE, OR OBVIOUS WEAR FOUND DURING A SCHEDULED INSPECTION COULD SERIOUSLY AFFECT THE AIRWORTHINESS OF THE HELICOPTER.

These inspection requirements constitute an approved inspection program for the Bell Helicopter Model 212. For the convenience of the operator, two separate Scheduled Inspections are provided as follows:

Part A scheduled inspections consists of a daily inspection, 100 hour/12 calendar month inspection, 1000 hour inspection, and a 3000 hour/5 year inspection.

Part B scheduled inspections consists of a 25 hour/30 day inspection, 300 hour inspection, 600 hour/12 month inspection, and a 3000 hour/5 year inspection.

Either Part A or Part B inspection program may be utilized. However, once a helicopter has been started on an inspection program, it shall be maintained on that program except as follows:

- If a helicopter is being inspected on the Part A inspection program and it is preferable to change to the Part B program, a complete Part A — 1000 Hour Inspection shall be accomplished. The helicopter may then be changed to the Part B inspection program beginning with a 25 Hour/15 Day Inspection.
- If a helicopter is being inspected on the Part B inspection program and it is preferable to change to the Part A program, a complete Part B — 600 Hour/12 Month Inspection shall be accomplished.

The helicopter may then be changed to the Part A inspection program beginning with a Daily Inspection.

The inspection intervals given in this chapter are the maximum permitted. Do not exceed these intervals. The owner/operator is responsible for increasing the scope and the frequency of the inspections as necessary. Make sure the helicopter is maintained safely during all unusual local changes, such as environmental conditions, helicopter use, etc. You can request changes to the requirements in this chapter through the local Aviation Authority.

The inspection intervals and the component overhaul schedule provided in this chapter are applicable only to Bell Helicopter Textron approved parts.

NOTE

The time period given for the overhaul of a component (or the failure to give a time period for the overhaul of a component) does not constitute a warranty of any kind. The only warranty applicable to the helicopter or any component is the warranty included in the Purchase Agreement for the helicopter or the component.

The Time Between Overhaul (TBO) and the inspection periods are determined through experience, tests, Lead The Fleet (LTF), or any other special programs and the judgement of Bell Helicopter Textron engineers. They are subject to change only by Bell Helicopter Textron or an approved Airworthiness Authority.

Changes to the TBO will be introduced by either revision to this chapter or a Technical Bulletin.

Every calendar and hourly inspection is a thorough visual inspection to determine the airworthiness of the helicopter and the components. Qualified persons must do the inspections in accordance with quality standard aircraft practices and the applicable maintenance manuals. Bell Helicopter Textron considers that it is mandatory to obey all the applicable Alert Service Bulletins (ASB) and the Airworthiness Directives (AD).

Component operating time records are necessary for components that have scheduled maintenance procedures, which are different from those of the airframe. It is the owner/operator's responsibility to keep the Historical Service Records (HSR) for the applicable component and to do the necessary maintenance procedures.

Before each inspection, remove or open the necessary cowlings, fairing, inspection doors, and panels.

5-2. INSPECTION REQUIREMENTS

This manual does not include specific inspections required by the FAA or other government regulatory authorities. These specific inspections are given by your government regulatory authority. Refer to their requirements for these specific inspections.

The owner/operator of the helicopter is responsible for the maintenance done on the helicopter. It is the owner/operator's responsibility to:

1. Establish, maintain, and review the log books for discrepancies.
2. Make sure the Alert Service Bulletins (ASB), the Airworthiness Directives (AD), and the special inspections are done when they are required to be done.
3. Make sure the scheduled inspections, the special inspections, and the required tests for all of the installed kits are complied with.
4. Make sure all parts and components for which Historical Service Records are required have documented traceability to their original installation in the helicopter.

WARNING

ALL PARTS REMOVED, DUE TO REACHING THEIR LIMITS OR AS A RESULT OF AN ACCIDENT/INCIDENT INSPECTION AND DEEMED UNAIRWORTHY, SHALL BE PERMANENTLY MARKED AS SCRAP OR PHYSICALLY DESTROYED TO THE

EXTENT THAT THERE IS NO CHANCE OF REPAIR OR INSTALLATION ON ANY HELICOPTER OR COMPONENT.

5. Make sure all limited life parts that have completed their published operating limits are replaced.
6. Make sure all of the components that have completed their published overhaul periods are overhauled.
7. Make sure all of the maintenance that is done on the helicopter is done by an approved maintenance organization.

The maintenance organization/person doing the maintenance is responsible for the quality of the maintenance done.

The owner/operator may choose to ask the maintenance organization/person doing the maintenance to perform the tasks listed by prior arrangement through a separate formal agreement.

5-3. CRASH DAMAGE

Because of the many possible combinations that can result from crash damage, it is not possible to include the specific repair tasks in this category. The helicopter mechanic must make an analysis of the crash damage for each situation. Do the repair in accordance with the degree of damage to the specific part and the applicable repair procedures in this manual. Call Product Support Engineering with your analysis of the crash damage.

5-4. TYPES OF INSPECTIONS

1. The maintenance procedures may include scheduled inspections, special inspections, conditional inspections, component interim inspections, and component overhaul inspections.

a. Scheduled inspections must occur at specified operating intervals. The intervals may be in operating time (hours), cycles, torque events (RIN), calendar (days, months, years) or other assigned units. This makes sure that the helicopter is airworthy.

- Scheduled inspections — Part A consists of:



- Daily inspection — Accomplish daily before flight operation.
 - 100 hours/12 calendar months — Accomplish each 100 hours of flight operation or 12 calendar months, whichever comes first.
 - 1000 hours — Accomplish each 1000 hours of flight operation.
 - 5000 hours/5 years — Accomplish each 5000 hours of flight operation or each 60 calendar months, whichever comes first.
- Scheduled inspections — Part B consists of the following:
 - 25 hours/30 days — Accomplish each 25 hours of flight operation or each 30 days, whichever comes first.
 - 300 hours/12 months — Accomplish each 300 hours of flight operation or each 12 calendar months, whichever comes first.
 - 600 hours/12 months — Accomplish each 600 hours of flight operation or each 12 calendar months, whichever comes first.
 - 5000 hours/5 years — Accomplish each 5000 hours of flight operation or each 60 calendar months, whichever comes first.
- b.** Special inspections are of a temporary nature or of a special interval that is not consistent with the scheduled inspections.
- c.** Conditional inspections do not occur at a specified time. A conditional inspection is the result of known or suspected unusual event, known or suspected malfunctions, or defects.
- d.** An interim inspection occurs between overhauls.
- e.** The component overhaul schedule gives the elapsed operating time at which a component must be removed, disassembled, examined for condition, and overhauled, in accordance with data approved by Bell Helicopter Textron.
- 2.** Airworthiness limitations — Replace components in accordance with Airworthiness Limitations Schedule (Chapter 4).
- 3.** Lubrication and servicing requirements are in addition to those stated in this chapter (Chapter 12).
- 4.** For corrosion control refer to the Corrosion Control Guide, CSSD-PSE-87-001 and the BHT-ALL-SPM.
- 5.** For the PT6T-3/-3B engines, refer to the Pratt & Whitney Canada Maintenance Manual for the scheduled inspection, special inspection, conditional inspection, and component overhaul schedule.
- 6.** For the common Bell Helicopter Textron approved optional equipment that is integrated into this maintenance manual, refer to this chapter for the scheduled inspection, conditional inspection, component interim inspection, and component overhaul inspection.
- 7.** For all other Bell Helicopter Textron approved equipment, refer to the applicable Service Instruction for the scheduled inspection, special inspection, conditional inspection, component interim inspection, and component overhaul inspection.
- 8.** For the inspection requirements for optional equipment approved under Supplement Type Certificate (STC), refer to the applicable STC documentation. Maintenance and inspection of these items are the responsibility of the owner/operator.

5-5. DEFINITIONS

- Inspect, check, examine — Determine condition relative to an established standard.
- Condition — The state of being of an item as related to serviceable or unserviceable standard.
- Security — The presence of attaching parts that are properly tightened or appear to be, and the presence of properly installed (as required) locking devices such as lockwire, cotter pins, or other.
- Standard — An established rule or measure to determine condition.
- Damage — Physical deterioration whereby the standard renders the condition or an item acceptable or not acceptable for continuous use.



- Discard — Reject a component that has damage that cannot be repaired. To permanently remove from service.
- Preventive maintenance — Simple or minor preservation and the replacement of small standard parts not involving complex assembly operations.
- Maintenance — Inspection, overhaul, repair, preservation, and the replacement of parts, but excludes preventive maintenance.
- Operating time — Time required to be recorded in historical record sheets or helicopter logs. Operating time to be recorded may be identified as follows:
 - Time in service — Time from the moment a helicopter leaves the surface of the earth until it touches down at the next point of landing. Time during which the engine and rotor are turning with the helicopter on the ground is not taken into account.
 - Calendar time — Elapse time starts the day the inspection is accomplished, the component is installed, or the rotor is turned for the first time and ends on the last day of the month that the time limit expires. Calendar time shall be recorded without interruption. Removal of the component or storage of the helicopter etc. does not stop calendar time.
- Planned event — Occurrence of interval in which a specific action is to be taken as in the case of preventive maintenance, scheduled overhaul, or replacement in accordance with maximum airworthiness life guidelines.
- Lead The Fleet (LTF) Program — This is a program to validate the performance of an approved product improvement or a change to a maintenance interval. The engineering aspects of this change are approved. The program is closely monitored by Bell Helicopter Textron in an operational environment with selected operators.

- Special Programs — These are approved programs that may be initiated under certain special conditions to meet specific requirements. These programs will be clearly defined through a plan and the engineering and maintenance aspects will be approved by the regulatory authorities.

5-6. INSPECTION AND OVERHAUL TOLERANCE

WARNING

DO NOT APPLY THESE TOLERANCES TO PARTS WITH A LIMITED AIRWORTHINESS LIFE (CHAPTER 4).

The Bell Helicopter Textron approved tolerance for scheduled inspections, special inspections, interim inspections, and overhaul intervals, unless otherwise stated, is 10% or up to a maximum of 300 hours operating time/6 months calendar time, whichever is less. The tolerances are established for maintenance scheduling convenience only.

Scheduled inspections, special inspections, interim inspections, or overhaul intervals required beyond the stated tolerances must be approved by Product Support Engineering.

NOTE

The following is only applicable for those operators whose governing aviation authority requires to specifically approve the inspection and overhaul tolerance.

If approval of the inspection and overhaul tolerance is required by the applicable governing aviation authority, this is the responsibility of the owner/operator.

Refer to the Pratt & Whitney Canada PT6T-3/-3B Maintenance Manual for inspection and overhaul tolerances.

The following provides examples of when hourly, calendar, or hourly/calendar inspection tolerances have been applied:

**Hourly Example (10% or up to a maximum of 300 hours, whichever is less):**

300-HOUR INSPECTION DUE AT:	MAXIMUM ALLOWED TOLERANCE	INSPECTION CARRIED OUT AT:	NEXT 300-HOUR INSPECTION DUE AT:
3400 Hours	10% of 300 hours = 30 hours	3430 Hours (10% tolerance applied)	3730 Hours
3730 Hours	10% of 300 hours = 30 hours	3750 Hours (within 10% tolerance)	4050 Hours
4050 Hours	10% of 300 hours = 30 hours	4050 Hours (tolerance not applied)	4350 Hours

Calendar Example (10% or up to a maximum of 6 months calendar time, whichever is less):

12-MONTH INSPECTION DUE ON:	MAXIMUM ALLOWED TOLERANCE	INSPECTION CARRIED OUT ON:	NEXT 12-MONTH INSPECTION DUE ON:
June 10, 2010 ^{△1}	10% of 12 months = 1.2 months	July 8, 2010 (within 10% tolerance)	July 31, 2011 ^{△2}
July 31, 2011	10% of 12 months = 1.2 months	June 15, 2011 (completed early)	June 30, 2012 ^{△2}
June 30, 2012	10% of 12 months = 1.2 months	June 30, 2012 (tolerance not applied)	June 30, 2013 ^{△2}

NOTE:

^{△1} Date of the first 12-Month Inspection carried out.

^{△2} The last day of the month applies for the next inspection ([paragraph 5-5](#), calendar time). For inspection intervals that are measured in days rather than months, the calendar time ends on the day that the time limit expires on, not the end of the month.

Hourly/Calendar Example (10% or up to a maximum of 300 hours operating time/6 months calendar time, whichever is less):

1200-HOUR/ 24-MONTH INSPECTION DUE AT:	MAXIMUM ALLOWED TOLERANCE	INSPECTION CARRIED OUT AT:	NEXT 1200-HOUR/ 24-MONTH INSPECTION DUE AT:
3400 Hours/ June 30, 2010	10% of 1200 hours = 120 hours or 10% of 24 months = 2.4 months	3400 Hours/July 30, 2010 (within 6 months calendar tolerance)	4600 Hours/ July 31, 2012 ^{△1}



Hourly/Calendar Example (10% or up to a maximum of 300 hours operating time/6 months calendar time, whichever is less): (Cont)

1200-HOUR/ 24-MONTH INSPECTION DUE AT:	MAXIMUM ALLOWED TOLERANCE	INSPECTION CARRIED OUT AT:	NEXT 1200-HOUR/ 24-MONTH INSPECTION DUE AT:
4600 Hours/ July 31, 2012	10% of 1200 hours = 120 hours or 10% of 24 months = 2.4 months	4700 Hours/April 2, 2012 (within 120 hours tolerance)	5900 Hours/ April 30, 2014 [△] ₁
5900 Hours/ April 30, 2014	10% of 1200 hours = 120 hours or 10% of 24 months = 2.4 months	5980 Hours/May 3, 2014 (within 120 hours and 2.4 month calendar tolerance)	7180 Hours/ May 31, 2016 [△] ₁

NOTE:

[△]₁ The last day of the month applies for the next inspection ([paragraph 5-5](#), calendar time). For inspection intervals that are measured in days rather than months, the calendar time ends on the day that the time limit expires on, not the end of the month.

Hourly/Calendar Example (10% or up to a maximum of 300 hours operating time/6 months calendar time, whichever is less):

5000-HOUR/ 5 YEAR INSPECTION DUE AT:	MAXIMUM ALLOWED TOLERANCE	INSPECTION CARRIED OUT AT:	NEXT 5000-HOUR/ 5 YEAR INSPECTION DUE AT:
6000 Hours/ December 31, 2010	10% of 5000 hours = 500 hours (maximum allowed is 300 hours) or 10% of 60 months = 6 months	6000 Hours/January 15, 2011 (within 6 months calendar tolerance)	9000 Hours/ January 31, 2016 [△] ₁
9000 Hours/ January 31, 2016	10% of 5000 hours = 500 hours (maximum allowed is 300 hours) or 10% of 60 months = 6 months	9100 Hours/January 2, 2016 (within 300 hours tolerance)	12,100 Hours/ January 31, 2021 [△] ₁
12,100 Hours/ January 31, 2021	10% of 5000 hours = 500 hours (maximum allowed is 300 hours) or 10% of 60 months = 6 months	12,175 Hours/February 20, 2021 (within 300 hour and 6 months calendar tolerance)	15,175 Hours/ February 28, 2026 [△] ₁

NOTE:

[△]₁ The last day of the month applies for the next inspection ([paragraph 5-5](#), calendar time). For inspection intervals that are measured in days rather than months, the calendar time ends on the day that the time limit expires on, not the end of the month.

SCHEDULED INSPECTIONS

5-7. SCHEDULED INSPECTIONS

Part A — Inspect helicopter daily, each 100 hours/12 calendar months, each 1000 hours, each 3000 hours/5 years.

Part B — Inspect helicopter each 25 hours/30 days, each 300 hours, each 600 hours/12 calendar months, each 3000 hours/5 years.

SCHEDULED INSPECTIONS

5-8. DAILY INSPECTION — PART A

DATA REFERENCE	INSPECTION TASK DESCRIPTION	INITIAL	
		MECH	OTHER
	<p>DATE: _____ W.O. _____</p> <p>FACILITY: _____</p> <p>HELICOPTER S/N: _____</p> <p>REGISTRY NO.: _____</p> <p>TOTAL TIME: _____</p> <p>SIGNATURE: _____</p> <p style="text-align: center;">NOTE</p> <p style="text-align: center;">For helicopters on the Part A inspection program, accomplish the following checks daily before flight operation.</p> <p><u>GENERAL</u></p> <p>1. Each listed inspection item or maintenance function is to be performed in accordance with the referenced Maintenance Manual or BHT-212-CR&O manual chapter specified.</p> <p>2. Refer to the Pratt & Whitney Canada PT6T-3/-3B Maintenance Manual for engine inspection requirements.</p> <p><u>PRELIMINARY REQUIREMENTS</u></p> <p>1. Use medium helicopter corrosion control guide to establish helicopter corrosion control program.</p> <p>2. Replace all finite life components that have completed published operating limitations.</p> <p>3. Overhaul all components that have completed published overhaul periods.</p> <p>4. Lubricate and service helicopter as required.</p>		
Corrosion Control Guide, CSSD-PSE-87-001	1. Use medium helicopter corrosion control guide to establish helicopter corrosion control program.		
Chapter 4	2. Replace all finite life components that have completed published operating limitations.		
Chapter 5	3. Overhaul all components that have completed published overhaul periods.		
Chapter 12	4. Lubricate and service helicopter as required.		



SCHEDULED INSPECTIONS

5-8. DAILY INSPECTION — PART A (CONT)

DATA REFERENCE	INSPECTION TASK DESCRIPTION	INITIAL	
		MECH	OTHER
Chapter 5	<p>5. Review Special Inspections and carry out applicable inspections.</p> <p>6. Examine all inspection windows and sight glasses for cracking, crazing, and discoloration. If any of these conditions are present the part must be removed and replaced prior to returning helicopter for service.</p>		
Service Instructions (SI)	<p>7. Make sure that all required inspections of installed BHT kits are not covered in this inspection have been performed, as applicable.</p>		
Chapter 21	<p><u>BLEED AIR HEATING SYSTEM COMPONENTS</u></p> <p>1. Visually inspect heater compartment for cleanliness, condition, and security of heating system components, wiring, ducts, supports, and structure for damage and corrosion.</p> <p>2. Visually inspect overhead ventilating system components for condition and security.</p> <p>3. Visually inspect heat/vent air ducts for condition and security.</p> <p>4. Visually inspect ventilation/defog components for condition and security.</p>		
Chapter 25	<p><u>CREW/PASSENGER SEATS</u></p> <p>1. Visually inspect crew seats for condition, security, and operation.</p> <p>2. Visually inspect crew seats restraints for condition, security, and operation.</p> <p>3. Visually inspect passenger seats for condition and security.</p> <p>4. Visually inspect passenger seats restraints for condition and security.</p>		
Chapter 25	<p><u>MISCELLANEOUS FURNISHINGS</u></p> <p>Visually inspect miscellaneous furnishings (map and data case, first aid kit, and emergency equipment) for condition and security.</p>		

SCHEDULED INSPECTIONS

5-8. DAILY INSPECTION — PART A (CONT)

DATA REFERENCE	INSPECTION TASK DESCRIPTION	INITIAL	
		MECH	OTHER
Chapter 26	<p><u>FIRE EXTINGUISHERS</u></p> <p>Visually inspect cockpit and cabin portable fire extinguishers and engine compartment fire extinguisher containers for security and condition.</p>		
Chapter 28	<p><u>FUEL SYSTEM</u></p> <p>Visually inspect fuel samples for contamination.</p>		
Chapter 29	<p><u>HYDRAULIC SYSTEMS</u></p> <p>1. Visually inspect the following:</p> <ul style="list-style-type: none"> a. Hydraulic system 1 and 2 filter bypass indicator buttons — not extended. b. Collective and cyclic servo actuators and boost tubes for leaks, damage, and security. c. Hydraulic system 1 and 2 pumps for leaks, damage, and security. d. Hydraulic system 1 and 2 valve and filter modules for leaks, damage, and security. e. Hydraulic system 1 and 2 lines, hoses, and fittings for leaks, damage, chafing, kinking, and security. f. Hydraulic system 1 and 2 reservoirs for proper fluid levels, damage, corrosion, and security. g. Tail rotor hydraulic actuator and hoses for leakage, corrosion, and security. <p>2. Remote hydraulic filter bypass indicator (located in right nose window) — confirm not tripped.</p>		
Chapter 30	<p><u>WINDSHIELD WIPER</u></p> <p>Visually inspect windshield wiper blades for serviceability and security.</p>		

SCHEDULED INSPECTIONS

5-8. DAILY INSPECTION — PART A (CONT)

DATA REFERENCE	INSPECTION TASK DESCRIPTION	INITIAL	
		MECH	OTHER
Chapter 32	<p><u>LANDING GEAR SYSTEM</u></p> <p>1. Visually inspect landing gear as follows:</p> <p style="padding-left: 40px;">a. Forward crosstube assembly and retention caps for condition and security of attachment.</p> <p style="padding-left: 40px;">b. Aft crosstube assembly and retention caps for condition and security of attachment.</p> <p style="padding-left: 40px;">c. Skid tubes and skid shoes for condition and security of attachment. Replace skid shoes that are worn into shoe surface. Repair weld beads as required.</p> <p style="padding-left: 40px;">d. Fuselage supports for wear, damage, and security of attachment.</p> <p style="padding-left: 40px;">e. If installed, landing gear forward crosstube crew step fittings for corrosion, damage, and security in area of attachment.</p> <p style="padding-left: 40px;">f. Emergency float reservoir pressure indicator for proper charge indication (if installed).</p> <p style="padding-left: 40px;">g. Floats for proper stowage and condition (if installed).</p> <p>2. Visually inspect tail skid for deformation and security of attachment.</p>		
Chapter 52	<p><u>DOORS, WINDOWS, AND EMERGENCY EXIT</u></p> <p>1. Visually inspect nose door for obvious damage, security of attachment, proper latching, and seal for condition.</p> <p>2. Visually inspect all windows for damage. Crew door windows, cargo hinged door window, passenger sliding door windows, cabin roof windows, cabin lower nose windows and windshields.</p> <p>3. Visually inspect crew door emergency release pins for security.</p> <p>4. Visually inspect crew and cabin doors for condition, security, and freedom of operation.</p>		

SCHEDULED INSPECTIONS

5-8. DAILY INSPECTION — PART A (CONT)

DATA REFERENCE	INSPECTION TASK DESCRIPTION	INITIAL	
		MECH	OTHER
Chapter 53	<p>5. Visually inspect avionics/electrical and heater compartment doors for condition and security of attachment. Latches for proper operation.</p> <p><u>FUSELAGE</u></p> <p>— General Visual Inspection</p> <p>1. Fuselage exterior for condition and damage to protective finish.</p> <p>2. Fuselage underside for evidence of fuel and hydraulic fluid leakage.</p> <p>3. All cowlings and fairings for condition and security, missing fasteners, cracks, and proper operation of latches.</p> <p>4. Inspect tailboom fuselage attachment points for security.</p> <p>5. Pitot tube(s) and static ports for obstruction and damage.</p> <p>6. Fuselage interior for evidence of water entrapment.</p> <p style="margin-left: 20px;">a. Nose compartment.</p> <p style="margin-left: 20px;">b. Pilot and passenger cabin.</p> <p style="margin-left: 20px;">c. Electrical compartment.</p> <p style="margin-left: 20px;">d. Heater compartment.</p> <p style="margin-left: 20px;">e. Baggage compartment.</p>		
Chapter 53	<p><u>TAILBOOM</u></p> <p>1. Inspect tailboom exterior structure for general condition.</p>		
Chapter 52	<p>2. Inspect baggage compartment interior for condition and cleanliness.</p> <p>3. Check baggage compartment door for damage, proper operation, and security.</p>		

SCHEDULED INSPECTIONS

5-8. DAILY INSPECTION — PART A (CONT)

DATA REFERENCE	INSPECTION TASK DESCRIPTION	INITIAL	
		MECH	OTHER
Chapter 62	<p>4. Inspect driveshaft and intermediate gearbox covers for damage and security.</p> <p><u>MAIN ROTOR BLADES</u></p> <p>— Detailed Visual Inspection</p> <p>1. Main rotor blades for condition, damage, security, and cleanliness.</p>		
Chapter 62	<p><u>MAIN ROTOR HUB</u></p> <p>— Detailed Visual Inspection</p> <p>1. Main rotor hub assembly (grips, drag braces, trunnion, pillow blocks, static stops, and mast nut) for condition and security.</p> <p>2. Hub assembly for proper oil level or grease lubrication.</p> <p>3. Main rotor yoke for evidence of cracks at pillow block bushing bores. Proper sealing of pillow blocks, yoke, and attaching through bolts, washers, nuts, and bushings.</p> <p>4. Inspect blade retention bolts for condition and security.</p>		
Chapter 62	<p><u>MAIN ROTOR CONTROLS</u></p> <p>— Detailed Visual Inspection</p> <p>1. Swashplate and support assembly and collective lever for condition and security.</p> <p>2. Scissors and sleeve assembly for security and condition.</p> <p>3. Pitch links, damper tubes, and connecting links for condition and security. Bearings for looseness.</p> <p>4. Stabilizer bar assembly for condition and security.</p> <p>5. Stabilizer bar dampers for condition, security, and proper fluid level.</p>		

SCHEDULED INSPECTIONS

5-8. DAILY INSPECTION — PART A (CONT)

DATA REFERENCE	INSPECTION TASK DESCRIPTION	INITIAL	
		MECH	OTHER
Chapter 63	<p><u>ENGINE-TO-TRANSMISSION MAIN DRIVESHAFT</u></p> <p>1. Visually inspect main driveshaft for condition and security.</p> <div style="text-align: center; margin: 10px 0;"> <div style="border: 1px solid black; padding: 2px; display: inline-block;">WARNING</div> </div> <p>CAUSE OF ANY DISCOLORATION SHALL BE DETERMINED AND CORRECTED PRIOR TO NEXT FLIGHT.</p> <p>2. Visually inspect main driveshaft forward and aft couplings, boots, seals, and surrounding area for grease leakage, damage, corrosion, and evidence of overheat as indicated by TEMP-PLATES or coupling discoloration. A change in color of any yellow bordered TEMP-PLATE, from white/off-white to black, will indicate a possible overheat condition and/or component degradation (step 3). If one or more of the red bordered TEMP-PLATE dots change from white/off-white to black, an overheat condition is present and may require replacement of both outer and inner couplings.</p> <p>3. Visually inspect overheat TEMP-PLATES for condition and security. TEMP-PLATES must not show evidence of overtemperature indication, deterioration, debonding, or excessive discoloration of the epoxy overcoating.</p>		
Chapter 63	<p><u>MAIN ROTOR MAST</u></p> <p>— Detailed Visual Inspection</p> <p>1. Mast assembly for security, corrosion, and mechanical damage. Pay particular attention to area contacted by main rotor static stops and damper assembly/adaptor set splines.</p> <p>2. Mast nut for security.</p> <p>3. Inspect lower area for evidence of oil leaks at mast bearing cap.</p>		

SCHEDULED INSPECTIONS

5-8. DAILY INSPECTION — PART A (CONT)

DATA REFERENCE	INSPECTION TASK DESCRIPTION	INITIAL	
		MECH	OTHER
Chapter 63 and SI 212-6	<p><u>ROTOR BRAKE QUILL AND DISC ASSEMBLY</u></p> <p>— Detailed Visual Inspection</p> <ol style="list-style-type: none"> 1. Rotor brake quill for condition, damage, and leaking. 2. Rotor brake for condition, damage, and leaking. 3. Rotor brake disc for warpage. 		
Chapter 63	<p><u>TRANSMISSION, ENGINE, AND COMBINING GEARBOX OIL COOLING</u></p> <p>— Detailed Visual Inspection</p> <ol style="list-style-type: none"> 1. Oil coolers for leaking, damage, and obstruction. 2. Oil cooler hoses and tubes for leaking, damage, chafing, and fraying. 3. Oil cooler blowers for damage and obstruction. 		
Chapter 64	<p><u>TAIL ROTOR HUB AND BLADE ASSEMBLY</u></p> <p>— Detailed Visual Inspection</p> <div style="text-align: center; margin: 10px 0;"> <div style="border: 1px solid black; padding: 2px 5px; display: inline-block;">WARNING</div> </div> <p style="text-align: center;">NO CRACKS ARE PERMITTED ON ANY SURFACE OF THE TAIL ROTOR BLADES.</p> <ol style="list-style-type: none"> 1. Tail rotor blades for condition of bond lines, cracks, corrosion, leading edge erosion, damage, security, and cleanliness. Clean blades are required to maintain enhanced visibility for safety. 2. Tail rotor hub for security, corrosion, and condition. 		

SCHEDULED INSPECTIONS

5-8. DAILY INSPECTION — PART A (CONT)

DATA REFERENCE	INSPECTION TASK DESCRIPTION	INITIAL	
		MECH	OTHER
Chapter 65	<p>3. Flapping bearings and pitch change bearings for excessive looseness and freedom of movement through full range of travel with anti-torque pedals positioned full right and then full left.</p> <p>4. Tail rotor pitch change links, crosshead, pitch horns, counterweight arms, and links for security, corrosion, and condition.</p> <p>5. Pitch link bearing and counterweight link bearing looseness shall not exceed 0.015 inch (0.381 mm) axial. Check freedom of movement through full range of travel with anti-torque pedals positioned full right and then full left.</p> <p>6. Pitch change links for binding with tail rotor blade moved to both full flapping positions. Binding is not acceptable.</p> <p><u>TAIL ROTOR DRIVESHAFT</u></p> <p>1. Hanger assemblies — bearings and surrounding areas for evidence of grease leakage, condition, damage, security, corrosion, and overheating. Discoloration of bearing (color change to blue to blue/black in color) or multi-color appearance of hanger that darkens adjacent to bearing is evidence of overheating. Brown color of bearing shield is normal and is not evidence of overheating.</p> <p>2. Driveshaft sections for cracks, rivet failure, distortion, dents, corrosion, and damage to anodized finish.</p> <p>3. Clamp sets for condition, security, and proper installation.</p>		

SCHEDULED INSPECTIONS

5-8. DAILY INSPECTION — PART A (CONT)

DATA REFERENCE	INSPECTION TASK DESCRIPTION	INITIAL MECH OTHER	
Chapter 65	<div style="text-align: center; margin-bottom: 20px;">  <p>WARNING</p> </div> <p>CAUSE OF ANY DISCOLORATION SHALL BE DETERMINED AND CORRECTED PRIOR TO NEXT FLIGHT.</p> <p>4. Flexible couplings and surrounding areas for grease leakage, damage, corrosion, and evidence of overheat as indicated by TEMP-PLATES or coupling discoloration. A change in color of one or more of the red bordered TEMP-PLATE dots from white/off-white to black indicates an overheat condition and may require replacement of both outer and inner couplings (step 5).</p> <p>5. Overheat TEMP-PLATES for condition and security. TEMP-PLATES must not show evidence of over temperature indication, deterioration, debonding, or excessive discoloration of the epoxy overcoating.</p> <p><u>INTERMEDIATE GEARBOX</u></p> <p>— Detailed Visual Inspection</p> <p>1. Gearbox assembly for security, condition, corrosion, damage, and oil leaking.</p>		



SCHEDULED INSPECTIONS

5-8. DAILY INSPECTION — PART A (CONT)

DATA REFERENCE	INSPECTION TASK DESCRIPTION	INITIAL MECH OTHER	
Chapter 65	<div style="text-align: center; margin-bottom: 20px;"> <div style="border: 1px solid black; padding: 5px; display: inline-block;">WARNING</div> </div> <p style="text-align: center;">CAUSE OF ANY DISCOLORATION SHALL BE DETERMINED AND CORRECTED PRIOR TO NEXT FLIGHT.</p> <p>2. Input and output quill flexible couplings and surrounding area for grease leakage, damage, corrosion, and evidence of overheat as indicated by TEMP-PLATES or coupling discoloration. A change in color of one or more of the red bordered TEMP-PLATE dots from white/off-white to black indicates an overheat condition and may require replacement of both outer and inner couplings (step 3).</p> <p>3. Overheat TEMP-PLATES for condition and security. TEMP-PLATES must not show evidence of over temperature indication, deterioration, debonding, or excessive discoloration of the epoxy overcoating.</p> <p>4. Gearbox for proper oil level and oil for evidence of contamination.</p> <p>5. Deleted.</p> <p><u>TAIL ROTOR GEARBOX</u></p> <p>— Detailed Visual Inspection</p> <p>1. Gearbox assembly for security, condition, corrosion, damage, and oil leaking.</p>		

SCHEDULED INSPECTIONS

5-8. DAILY INSPECTION — PART A (CONT)

DATA REFERENCE	INSPECTION TASK DESCRIPTION	INITIAL	
		MECH	OTHER
	<p style="text-align: center;">WARNING</p> <p>CAUSE OF ANY DISCOLORATION SHALL BE DETERMINED AND CORRECTED PRIOR TO NEXT FLIGHT.</p> <p>2. Input quill flexible coupling and surrounding area for grease leakage, damage, corrosion, and evidence of overheat as indicated by TEMP-PLATES or coupling discoloration. A change in color of one or more of the red bordered TEMP-PLATE dots from white/off-white to black indicates an overheat condition and may require replacement of both outer and inner couplings.</p> <p>3. Overheat TEMP-PLATES for condition and security. TEMP-PLATES must not show evidence of overtemperature indication, deterioration, debonding, or excessive discoloration of the epoxy overcoating.</p> <p>4. Gearbox for proper oil level and oil for evidence of contamination.</p>		
Chapter 67	<p><u>ELEVATORS</u></p> <p>— Detailed Visual Inspection</p> <p>1. Elevators for damage and security.</p>		
Chapter 71	<p><u>LEFT POWER SECTION</u></p> <p>— Detailed Visual Inspection</p> <p>1. Gas generator case for cracks, buckled areas, and hot spots.</p> <p>2. Oil and fuel hoses and tubes for chafing, leaking, and security.</p> <p>3. Electrical wiring for fraying, chafing, and security.</p>		

SCHEDULED INSPECTIONS

5-8. DAILY INSPECTION — PART A (CONT)

DATA REFERENCE	INSPECTION TASK DESCRIPTION	INITIAL	
		MECH	OTHER
Chapter 71	<p>4. Proper oil level.</p> <p><u>RIGHT POWER SECTION</u></p> <p>— Detailed Visual Inspection</p> <p>1. Gas generator case for cracks buckled areas, and hot spots.</p> <p>2. Oil and fuel hoses and tubes for chafing, leaking, and security.</p> <p>3. Electrical wiring for fraying, chafing, and security.</p> <p>4. Proper oil level.</p>		
Chapter 71	<p><u>REDUCTION GEARBOX</u></p> <p>— Detailed Visual Inspection</p> <p>1. Hoses and lines for security, leaks, and chafing.</p> <p>2. Oil filter impending bypass indicator button not extended.</p> <p>3. Proper oil level.</p>		
Chapter 71	<p><u>ENGINE AND REDUCTION GEARBOX MOUNTS</u></p> <p>— Detailed Visual Inspection</p> <p>1. Mounts for loose bearings and security.</p> <p><u>ENGINE FIREWALLS</u></p> <p>— Detailed Visual Inspection</p> <p>1. Firewalls for cracks, distortion, missing rivets, broken spot welds, and deteriorating seals or gaskets.</p>		



SCHEDULED INSPECTIONS

5-8. DAILY INSPECTION — PART A (CONT)

DATA REFERENCE	INSPECTION TASK DESCRIPTION	INITIAL	
		MECH	OTHER
Chapter 79	<p><u>ENGINE AIR MANAGEMENT SYSTEM</u></p> <p>— Detailed Visual Inspection</p> <ol style="list-style-type: none"> Exhaust ejector and ducts for condition, obstruction, and security. Air intake ducts and plenum for condition, obstruction, and security. 		
	<p><u>ENGINE OIL SYSTEM</u></p> <p>— Detailed Visual Inspection</p> <ol style="list-style-type: none"> Engine accessory and reduction gearboxes for oil leaks. Oil coolers for leaks, damage, or obstructions. 		
Chapter 95	<p><u>INSTRUMENTS</u></p> <p>— Detailed Visual Inspection</p> <ol style="list-style-type: none"> Instrument panel for cleanliness. All instruments, placards, decals, and markings for appearance and legibility. Check magnetic compass for condition and security. All compass cards for validity. 		
Chapter 96	<p><u>ELECTRICAL SYSTEMS</u></p> <p>— General Visual Inspection</p> <ol style="list-style-type: none"> Nose compartment electrical equipment for condition and security. Pedestal mounted avionics/electrical equipment for condition, cleanliness, and security. Overhead console for condition, cleanliness, and security. 		



SCHEDULED INSPECTIONS

5-8. DAILY INSPECTION — PART A (CONT)

DATA REFERENCE	INSPECTION TASK DESCRIPTION	INITIAL	
		MECH	OTHER
Chapter 96	4. All instrument lights, integrally lit panels, secondary lights, and map lights for serviceability.		
	5. All caution and warning lights for proper operation by using master caution, fire test, and baggage compartment smoke detector press to test functions.		
	6. Landing/search lights for condition and security.		
	7. Navigation and anticollision lights for condition and security.		
Chapter 97	<p><u>BATTERY SYSTEM</u></p> <p>— General Visual Inspection</p> <p>1. Battery and external connections for condition and security.</p> <p>2. Battery vent and drain tubes for obstruction and security.</p>		
	<p><u>ANTENNAS</u></p> <p>1. Visually inspect all antennas located on fuselage and tailboom for condition and security.</p>		
	<p><u>AVIONICS EQUIPMENT</u></p> <p>1. Visually inspect all avionics located in fuselage and tailboom for condition and security.</p>		



SCHEDULED INSPECTIONS

5-9. 100 HOURS/12 CALENDAR MONTHS — PART A

DATA REFERENCE	INSPECTION TASK DESCRIPTION	INITIAL	
		MECH	OTHER
	<p>DATE: _____ W.O. _____</p> <p>FACILITY: _____</p> <p>HELICOPTER S/N: _____</p> <p>REGISTRY NO.: _____</p> <p>TOTAL TIME: _____</p> <p>SIGNATURE: _____</p> <p style="text-align: center;">NOTE</p> <p style="text-align: center;">For helicopters on the Part A inspection program, accomplish each 100 hours of flight operation or after 12 calendar months, whichever comes first.</p> <p><u>GENERAL</u></p> <ol style="list-style-type: none"> 1. Each listed inspection item or maintenance function is to be performed in accordance with the referenced maintenance manual, chapter specified, or BHT-212-CR&O manual. 2. Refer to Pratt & Whitney Canada PT6T-3/-3B Maintenance Manual for engine inspection requirements. 3. Record all work accomplished during inspection in the helicopter maintenance record. 4. Check helicopter records for recorded discrepancies. 5. Accomplish complete Daily Inspection — Part A scheduled inspection program. 6. Review special inspections and perform any special inspection required. 7. Replace all finite life components that have completed published operating limitations. 8. Overhaul all components which have completed published overhaul periods. 		
Paragraph 5-16			
Chapter 4			
Paragraph 5-57			



SCHEDULED INSPECTIONS

5-9. 100 HOURS/12 CALENDAR MONTHS — PART A (CONT)

DATA REFERENCE	INSPECTION TASK DESCRIPTION	INITIAL	
		MECH	OTHER
Chapter 12	<p>9. Perform lubrication requirements.</p> <p style="text-align: center;">NOTE</p> <p>The following step is to be performed every 12 calendar months.</p> <p>10. Inspect all fuel system, oil system, and hydraulic system filler caps for proper functioning and sealing. Make sure the sealing O-rings within the filler caps are in good condition. Repair or replace the filler caps or replace sealing O-rings as required.</p> <p><u>POWER CHECK</u></p>		
Chapter 96	<p>1. Examine all electrical components, wires, cables and connectors in the area of the forward deck and transmission for chafing, general condition and security.</p> <p><u>GROUND RUN</u></p> <div style="text-align: center;">  </div> <p style="text-align: center;">GROUND RUN OF HELICOPTER TO BE ACCOMPLISHED BY QUALIFIED PERSONNEL ONLY.</p>		
Chapter 12	<p>1. Make sure applicable servicing requirements have been carried out.</p> <p>2. Check oil level of transmission, hydraulic tank, engine and tail rotor gearbox prior to running helicopter.</p> <p>3. Make sure that helicopter is ready for ground run and that surrounding area is clear.</p>		
BHT-212-FM-1	<p>4. Start the helicopter and conduct ground run at 100% N_R to check for leaks and ensure all systems are operational and parameters are within Flight manual limitations.</p> <p>5. Shut down the helicopter.</p>		



SCHEDULED INSPECTIONS

5-9. 100 HOURS/12 CALENDAR MONTHS — PART A (CONT)

DATA REFERENCE	INSPECTION TASK DESCRIPTION	INITIAL	
		MECH	OTHER
Chapter 21	<p><u>HEAT/VENT AIR DUCTS</u></p> <p>1. Visually inspect all heating, ventilation, cooling ducts, and controls for cracks, security and proper operation.</p> <p>Every sixth 100 hour inspection (600 hours) or 12 months:</p>		
Chapter 96	<p>2. Bleed air heating and ventilation/defog system components:</p> <p style="padding-left: 40px;">a. Perform functional check of bleed air heating system and components.</p> <p style="padding-left: 40px;">b. Perform functional check of defog blower.</p>		
Chapter 25	<p><u>MISCELLANEOUS FURNISHINGS</u></p> <p>1. Check all safety equipment for inspection due dates and operation.</p>		
Chapter 26	<p><u>FIRE PROTECTION</u></p> <p>1. Make sure fire extinguishers are properly charged.</p> <p>2. Baggage compartment smoke detector for condition and security.</p> <p>Every sixth 100 hour inspection (600 hours) or 12 months:</p> <p>1. Weight check crew and passenger cabin portable fire extinguishers.</p>		
Chapter 96	<p>2. Perform operational check of engine fire extinguishing system.</p> <p>3. Perform operational check of baggage compartment smoke detector.</p>		
Chapter 4	<p>4. Replace engine fire extinguisher container firing cartridges in accordance with specified service life.</p>		



SCHEDULED INSPECTIONS

5-9. 100 HOURS/12 CALENDAR MONTHS — PART A (CONT)

DATA REFERENCE	INSPECTION TASK DESCRIPTION	INITIAL	
		MECH	OTHER
Chapter 28	<p><u>FUEL SYSTEM</u></p> <p>1. Inspect all exposed fuel lines and connections for leakage, damage, and security.</p> <p>Every sixth 100 hour inspection (600 hours) or 12 months:</p> <p>2. Remove four access doors, located just forward of the aft crosstube, from the underside of the fuselage. Inspect fuel lines for evidence of leakage, damage, and security.</p>		
Chapter 29	<p><u>HYDRAULIC SYSTEMS</u></p> <p>1. Inspect all lines and hoses for security and general condition.</p> <p>Every sixth 100 hour (600 hours) inspection or 12 months:</p> <p style="text-align: center;">NOTE</p> <p>Hydraulic filter elements 205-076-034-003 are non-cleanable. It is recommended they be replaced every 600 hours or 12 months. Filter elements 205-076-034-007 are cleanable. The -003 and -007 elements are interchangeable; intermixing of different element types is not permitted.</p> <p>1. Remove and inspect hydraulic filter elements.</p> <p>2. Discard or clean filter elements as applicable.</p> <p>3. Install hydraulic filter elements.</p>		
Chapter 63	<p>4. Install 0 to 500 PSIG (0 to 3447 kPa) gauge in quick disconnect at rotor brake caliper. Slowly pull rotor brake handle through travel. Cylinder should generate 240 to 260 PSI (1655 to 1793 kPa) at any handle velocity and shall maintain 150 PSI (1034 kPa) minimum in over center position for 3 minutes. Adjust as necessary.</p> <p>5. Inspect rotor brake linings for wear (minimum thickness 0.150 inch (3.81 mm)).</p>		



SCHEDULED INSPECTIONS

5-9. 100 HOURS/12 CALENDAR MONTHS — PART A (CONT)

DATA REFERENCE	INSPECTION TASK DESCRIPTION	INITIAL	
		MECH	OTHER
Chapter 32	<p><u>LANDING GEAR SYSTEM</u></p> <p>— General Visual Inspection</p> <ol style="list-style-type: none"> Deleted. Deleted. Landing gear crosstube assemblies, skid tubes, and skid shoes, for condition and security of attachment. Inspect crosstube retention cap (rubber bumper pads) for condition and security of attachment. Deleted. Deleted. If installed, landing gear forward crosstube crew step fittings for corrosion, damage, and security in area of attachment. If edge sealant is damaged or missing, remove crew step and inspect crosstube for corrosion or damage. <p>— Restoration</p> <ol style="list-style-type: none"> Torque check crosstube to skid tube saddle bolts. Torque check forward and aft crosstube support fittings U bolts to 80 to 100 inch-pounds (9.0 to 11.3 Nm). Torque check ground handling wheel attachment eyebolts on skid tubes 40 to 58 foot-pounds (54 to 79 Nm). Eyebolts that rotate prior to reaching 40 foot-pounds (54 Nm) shall be removed and inspected for evidence of bending. No bending is permitted. 		
Chapter 52	<p><u>DOORS AND WINDOWS</u></p> <ol style="list-style-type: none"> Crew and passenger doors structure for corrosion, damage, distortion, and positive locking mechanisms. Seals for adherence, tears, separations, and deterioration. 		



SCHEDULED INSPECTIONS

5-9. 100 HOURS/12 CALENDAR MONTHS — PART A (CONT)

DATA REFERENCE	INSPECTION TASK DESCRIPTION	INITIAL	
		MECH	OTHER
<p>Chapter 53</p> <p>ASB 212-90-63 and TB 212-94-147</p>	<p>Every third 100 hour inspection (300 hours) or 12 months:</p> <p>2. Crew doors emergency jettison mechanism for condition and security. Perform operational check.</p> <p style="text-align: center;">NOTE</p> <p>The following inspection (step 3 and step 4) is for helicopters equipped with escape panels which may be identified by a rotating handle installed below the passenger door windows. The handle is labeled EMERGENCY RELEASE PULL COVER TURN LEFT AND PUSH.</p> <p>3. Inspect passenger door emergency egress panel pins and mechanisms for wear, corrosion, operation, and security.</p> <p>4. Perform operational check of passenger door escape panels.</p> <p>5. Passenger door window retainers and fillers (if applicable) for damage.</p> <p>6. Nose, electrical, and equipment compartment access doors for corrosion, damage, distortion, and positive locking mechanisms.</p> <p>7. Baggage compartment door for corrosion, damage, and positive locking.</p> <p>8. Inspect heated windshield, if installed, for condition and proper operation.</p> <p><u>TAILBOOM</u></p> <p>— General Visual Inspection</p> <p>1. Internal and external structure of tailboom for cracks, distortion, corrosion, and security.</p> <p>2. Inspect tailboom attachment points for cracks and security.</p> <p>3. Ensure all drain holes are open.</p>		



SCHEDULED INSPECTIONS

5-9. 100 HOURS/12 CALENDAR MONTHS — PART A (CONT)

DATA REFERENCE	INSPECTION TASK DESCRIPTION	INITIAL	
		MECH	OTHER
Chapter 65	<p>4. Torque check tail rotor gearbox mounting nuts by applying torque in tightening direction, do not exceed 200 inch-pounds (22.6 Nm). If any nut rotates under torque, inspect attachment hardware and tail rotor gearbox for serviceability.</p> <p>5. Torque check intermediate gearbox mounting bolts by applying torque in tightening direction, do not exceed 50 inch-pounds (5.65 Nm). If any bolt turns under torque, inspect attachment hardware and intermediate gearbox for serviceability.</p>		
ASB 212-00-110	<p>6. Inspect vertical fin spar caps for cracks and corrosion.</p> <p style="text-align: center;">NOTE</p> <p>If necessary, clean area with cloth dampened with MEK (C-309) or equivalent. Ventilate area to prevent breathing fumes.</p> <p>7. Inspect vertical fin spar caps forward side and web from upper tailboom skin to approximately 4 inches (101.6 mm) below upper tailboom skin as follows: Remove aft tailboom access door. Face aft and use bright light and small mirror to inspect area for cracks, especially near rivet holes.</p> <p>Every third 100 hour inspection (300 hours) or every 12 months:</p> <p>1. Inspect tailboom joints, splices, longerons, attach fittings, and attaching hardware for corrosion, damage, and cracks.</p>		
ASB 212-90-63	<p>2. Remove plug button at BS 99.00.</p> <p style="text-align: center;">NOTE</p> <p>Paint fissures are common in the splice area, cracks will be evident by black powder emanating from cracked area, and corrosion will leave evidence of white powder.</p> <p>3. Using a periscope or suitable means, inspect inside of longeron paying particular attention to cracking and/or corrosion in area of splice.</p> <p>4. Report any cracks to Product Support Engineering.</p> <p>5. Install plug button with sealant (C-308).</p>		



SCHEDULED INSPECTIONS

5-9. 100 HOURS/12 CALENDAR MONTHS — PART A (CONT)

DATA REFERENCE	INSPECTION TASK DESCRIPTION	INITIAL	
		MECH	OTHER
Chapter 53	<p><u>FUSELAGE</u></p> <ol style="list-style-type: none"> 1. Inspect fuselage tailboom attachment points for security. 2. Inspect fuselage tailboom attachment components and hardware for cracks with a 10X magnifying glass. Pay particular attention to interface between forward end of tailboom attachment fitting and cap angle (Figure 5-1). 3. Move pylon fore and aft. Using mast as lever, check friction dampers for freedom of movement and smooth operation. 4. Inspect transmission mounts, mounting brackets, and structure for cracked or broken parts. 5. Inspect lift link and fitting for cracks and security. 6. Cabin interior and exterior for corrosion and damage. 7. All compartments for evidence of water entrapment and corrosion. 8. Ensure all drain holes are open. 9. Inspect underside of fuselage: <ol style="list-style-type: none"> a. Fuselage structure for damage, corrosion, and working rivets. b. Exterior finish for condition and cleanliness. c. Evidence of excessive fluid leakage. d. Structure around landing gear for condition. e. Forward crosstube support structure for working fasteners, cracks, corrosion, and excessive wear. f. Aft crosstube support structure for working fasteners, cracks, corrosion, and excessive wear. 10. Fuselage bonded panels for damage and delamination. 11. Cabin roof structure: 		



SCHEDULED INSPECTIONS

5-9. 100 HOURS/12 CALENDAR MONTHS — PART A (CONT)

DATA REFERENCE	INSPECTION TASK DESCRIPTION	INITIAL	
		MECH	OTHER
	<p>a. Cabin roof structure, cowlings, and fairings for damage, delamination, and general condition.</p> <p>b. Cabin roof and cowling/fairing mounted antennas for condition and security.</p> <p>Every sixth 100 hour inspection (600 hours) or 12 months:</p> <p>1. Fuselage cabin structure:</p> <p>a. Fuselage structure for corrosion and damage to finish and sealant. Pay particular attention to edges of joints and seams and around fastener heads.</p> <p>b. Engine compartment floor and service deck at FS 155.06 to 241.22 for damage, delamination, and corrosion.</p> <p style="text-align: center;">NOTE</p> <p>To adequately inspect the following, it will be necessary to remove the auxiliary fuel tanks if installed.</p> <p>2. Pylon wall for damage, working fasteners, cracks, delamination, and corrosion.</p> <p><u>CENTER FUSELAGE</u></p> <p>Lower cyclic hydraulic actuator supports 212-030-286-001 and -002 in cargo hook compartment (hellhole).</p> <p style="text-align: center;">NOTE</p> <p>Inspection is not applicable to helicopter S/N 30790 and subsequent and helicopters modified in accordance with TB 212-76-12.</p> <p>1. Clean area around fuel vent line hole with MEK (C-309) or equivalent and remove finish from beam cap.</p> <p>2. Inspect each beam cap for hairline cracks using a bright light. Inspect inboard side of left and right main beams around fuel vent line that goes through cap extrusion at FS 131.00, WK 21.50, and BL 14.00. Pay particular attention to first high shear rivet hole above WL 22.00 at FS 129.00 (Figure 5-2, Detail A and Detail B).</p>		



SCHEDULED INSPECTIONS

5-9. 100 HOURS/12 CALENDAR MONTHS — PART A (CONT)

DATA REFERENCE	INSPECTION TASK DESCRIPTION	INITIAL	
		MECH	OTHER
Chapter 62	<p>3. Apply clear lacquer over cleaned area.</p> <p><u>MAIN ROTOR BLADE INSPECTION SYSTEM (BIS)</u></p> <p>— Inspect</p>		
BHT-212-CR&O and Chapter 96	<p>1. Test detector unit.</p> <p>2. Perform continuity check on blade conductor circuits.</p> <p>3. Remove BIS battery.</p> <p>4. Perform battery condition check on replacement battery. Install replacement battery.</p>		
Chapter 62	<p><u>MAIN ROTOR BLADES</u></p> <p>1. Wash main rotor blades with mild soap and water. Rinse and dry thoroughly.</p> <p>— Detailed Visual Inspection</p> <p>2. Main rotor blades upper and lower surfaces for condition of bond lines, doublers, and leading edge for erosion. Inspect blade surfaces for corrosion, cracks, damage, and voids.</p>		
Chapter 62	<p><u>MAIN ROTOR HUB</u></p> <p>— Detailed Visual Inspection</p> <p>1. Main rotor hub assembly (grips, drag braces, trunnion, pillow blocks, static stops, and mast nut) for condition and security.</p> <p>2. Hub assembly for proper oil level or grease lubrication.</p> <p>3. Main rotor yoke for evidence of cracks at pillow block bushing bores. Proper sealing of pillow blocks, yoke, and attaching through bolts, washers, nuts, and bushings.</p> <p>4. Inspect blade retention bolts for condition and security.</p>		



SCHEDULED INSPECTIONS

5-9. 100 HOURS/12 CALENDAR MONTHS — PART A (CONT)

DATA REFERENCE	INSPECTION TASK DESCRIPTION	INITIAL	
		MECH	OTHER
Chapter 62	<p><u>MAIN ROTOR CONTROLS</u></p> <p>1. Swashplate and support assembly:</p> <p style="padding-left: 40px;">a. Inspect for condition and security with special attention to gimbal ring attachment lugs.</p> <p style="text-align: center;">NOTE</p> <p style="padding-left: 40px;">The presence of black oxide powder will require investigation to determine the cause.</p> <p style="padding-left: 40px;">b. Inspect gimble ring bearings, liners, and attaching hardware for excessive looseness and wear. Gimble ring bearing and attaching bolt axial or radial looseness shall not exceed 0.005 inch (0.127 mm) and no binding is allowed.</p> <p>2. Disconnect flight control tubes from swashplate and collective lever assembly. Inspect six trunnion bearings 204-011-451-001 for 0.020 inch (0.508 mm) maximum axial play. Rotate bearings 180° and purge lubricate.</p> <p>3. Inspect collective levers for condition and evidence of corrosion, and scissors and sleeve assembly for security and condition.</p> <p>4. Inspect stabilizer bar dampers clamps for condition and evidence of corrosion.</p> <p>5. Inspect stabilizer bar assembly for condition and security. Pay particular attention to tubes P/N 204-011-328-001 and -011 for cracks. Closely inspect area covering 360°, 1.5 inches (38.1 mm) outboard from vertical bolt.</p> <p>6. Replace bearings MS20201KP8A or MS27641-8 in scissors levers 204-011-406.</p> <p>7. Replace bearings AN204KP6A or MS27641-6 in mixing levers 204-011-301.</p>		
Chapter 63	<p><u>TRANSMISSION</u></p> <p>1. Inspect mounts for damage and security. Check boots for condition and ensure boots are in place.</p>		



SCHEDULED INSPECTIONS

5-9. 100 HOURS/12 CALENDAR MONTHS — PART A (CONT)

DATA REFERENCE	INSPECTION TASK DESCRIPTION	INITIAL MECH OTHER	
Chapter 63	<p>2. Inspect lift link and attachments for corrosion, damage, and security. Check bearings for looseness.</p> <p>3. Inspect for evidence of oil leakage.</p> <p>4. Check all transmission chip detectors for debris and then clean.</p> <p>5. Test all transmission chip detectors electrical circuits.</p> <p>6. Refer to Special Inspection paragraph 5-25, paragraph 5-27 and paragraph 5-34 (as applicable) for transmission oil change and internal oil filter or full flow debris monitor inspection requirements.</p> <p>7. Every third 100 hour inspection (300 hours), torque check top case to ring gear case nuts, ring gear case to main case nuts, and main case to support case nuts 230 to 250 inch-pounds (25.99 to 28.25 Nm). Retorque as required.</p> <p><u>MAIN ROTOR MAST</u></p> <p>— Detailed Visual Inspection</p> <p>1. Inspect mast assembly for security, corrosion, and mechanical damage. Pay particular attention to area contacted by main rotor hub static stops, and damper assembly/adapter set splines.</p> <p>2. Inspect for evidence of oil leaks at mast bearing cap.</p>		



SCHEDULED INSPECTIONS

5-9. 100 HOURS/12 CALENDAR MONTHS — PART A (CONT)

DATA REFERENCE	INSPECTION TASK DESCRIPTION	INITIAL	
		MECH	OTHER
Chapter 64	<p><u>TAIL ROTOR HUB AND BLADE ASSEMBLY</u></p> <div style="text-align: center;">  <p>CAUTION</p> </div> <p>COUNTERWEIGHT BELLCRANK RETENTION NUTS P/N MS14145L6 OR ITS EQUIVALENT MS17826-6 ARE DESIGNATED AS ONE TIME USE ONLY. IF MAINTENANCE ACTION REQUIRES THAT IT BE REMOVED, THE COUNTERWEIGHT BELLCRANK NUT IS TO BE DISCARDED AND REPLACED WITH A NEW NUT. OVERTORQUING OR INCORRECT APPLICATION OF THE NUT COULD CAUSE MECHANICAL FAILURE RESULTING IN EXCESSIVE VIBRATION OR DAMAGE TO THE TAIL ROTOR BLADES.</p> <p>1. Inspect the tail rotor counterweight bellcrank (P/N 212-011-705-001) retention nuts for cracks, corrosion, and security. Reapply corrosion preventive compound (C-101) if nuts are not completely covered.</p> <p>Every third 100 hour inspection (300 hours) or every 12 months:</p>		
Chapter 18	<ol style="list-style-type: none"> 1. Dynamically balance tail rotor. 2. Torque check nuts on tail rotor blade retention bolts. 3. Torque check tail rotor retaining nut. 		
Chapter 65	<p><u>TAIL ROTOR GEARBOX</u></p> <ol style="list-style-type: none"> 1. Inspect chip detector for debris. If metallic particles are found, determine and correct cause. 2. Clean chip detector. 3. Test chip detector electrical circuit. 		
Chapter 65	<p><u>TAIL ROTOR DRIVESHAFT</u></p> <ol style="list-style-type: none"> 1. Hanger assemblies for cracks at mounting ears, corrosion, and security of attachment. 		



SCHEDULED INSPECTIONS

5-9. 100 HOURS/12 CALENDAR MONTHS — PART A (CONT)

DATA REFERENCE	INSPECTION TASK DESCRIPTION	INITIAL	
		MECH	OTHER
Chapter 65	<p>2. Hanger supports for condition and security of attachment.</p> <p>3. Driveshaft sections and attaching hardware for condition and security.</p> <p style="padding-left: 40px;">a. Condition of clamps for tail rotor driveshaft coupling to gearbox couplings (90° apart).</p> <p style="padding-left: 40px;">b. Inspect clamps for cracks in or near the bolt hole lugs.</p> <p><u>INTERMEDIATE GEARBOX</u></p> <p>1. Inspect chip detector for debris. If metallic particles are found, determine and correct cause.</p> <p>2. Clean chip detector.</p> <p>3. Test chip detector electrical circuit.</p>		
Chapter 67	<p><u>ELEVATOR</u></p> <p>— Detailed Visual Inspection</p> <p>1. Elevators for security, cracks, damage, loose or missing rivets, and corrosion.</p> <p>2. Check elevator attachment lugs at each end of elevator horn for cracks and security of attachment. Check elevator horn to elevator spar attaching bolts and surrounding joints for cracks and security of attachment.</p> <p>Every third 100 hour inspection (300 hours) or 12 months:</p> <p>1. Check left and right elevator assemblies for excessive axial and radial play using a dial indicator mounted on the tailboom, with stylus touching inboard edge of elevator near attachment bolt for axial measurement, and touching upper surface near attachment bolt for radial measurement. Applying light force to move elevator in required direction, check that radial movement does not exceed 0.010 inch (0.254 mm), and that axial movement is within 0.005 to 0.030 inch (0.127 to 0.762 mm). Adjust shims as required.</p> <p>2. Elevator rigging for proper setting and travel.</p>		



SCHEDULED INSPECTIONS

5-9. 100 HOURS/12 CALENDAR MONTHS — PART A (CONT)

DATA REFERENCE	INSPECTION TASK DESCRIPTION	INITIAL	
		MECH	OTHER
Chapter 67	<p>3. Check elevator horn for security, mechanical damage, and corrosion.</p> <p>4. Trailing edge tabs and tip caps for condition and security.</p> <p>Every sixth 100 hour inspection (600 hours) or 12 months:</p> <p>1. Remove left and right elevators.</p> <p>2. Clean elevator spars and inspect for corrosion.</p> <p>3. Clean internal bore of elevator horn and inspect for corrosion.</p> <p>4. With elevator control removed, attach a spring scale to hole in arm of horn where control tube is normally installed. Pull scale at right angle to arm, verify friction is 26 to 32 pounds (115.65 to 142.34 N). If friction is not within limits, adjust shim thickness.</p> <p>5. Install left and right elevators.</p> <p><u>FLIGHT CONTROLS</u></p> <p>— Detailed Visual Inspection</p> <p>1. Inspect all control tube assemblies for clearances, security, and general condition, paying particular attention to tail rotor and elevator control tubes for chafing and wear (maximum allowable wear 0.008 inch (0.2032 mm)).</p> <p>2. Control tube bellcranks, supports, and attaching hardware for corrosion, security, wear, and damage.</p> <p>Every sixth 100 hour inspection (600 hours) or 12 months:</p> <p>1. Collective flight controls:</p> <p style="padding-left: 40px;">a. Flight control systems bellcrank and control tubes for damage, chafing, corrosion, and security of attachment.</p> <p style="padding-left: 40px;">b. Friction shoes and liners for condition.</p> <p style="padding-left: 40px;">c. Check collective lever friction adjuster for operation.</p>		



SCHEDULED INSPECTIONS

5-9. 100 HOURS/12 CALENDAR MONTHS — PART A (CONT)

DATA REFERENCE	INSPECTION TASK DESCRIPTION	INITIAL	
		MECH	OTHER
Chapter 67	<p>d. Check for proper collective minimum friction.</p> <p>e. Check collective flight controls for smooth movement throughout full range of travel.</p> <p>2. Cyclic flight controls:</p> <p>a. Flight control systems bellcrank and control tubes for damage, chafing, corrosion, and security of attachment.</p> <p>b. Check cyclic stick friction adjuster for proper operation.</p> <p>c. Check for proper cyclic minimum friction (applicable to AFCS equipped helicopters).</p> <p>d. Check cyclic flight controls for smooth movement throughout full range of travel.</p> <p>3. Anti-torque flight controls:</p> <p>a. Flight control systems bellcrank and control tubes for damage, chafing, corrosion, and security of attachment.</p> <p>b. Check anti-torque friction adjuster for proper friction.</p> <p>c. Check anti-torque flight controls for smooth movement throughout full range of travel.</p> <p><u>COLLECTIVE AND CYCLIC FLIGHT CONTROL ACTUATORS</u></p> <p>— Detailed Visual Inspection</p> <p>1. Universal bearings for looseness.</p> <p>2. Input lever bearings and bolts for wear and looseness.</p> <p>3. Fasteners attaching cylinder lower supports to structure for looseness.</p> <p>4. Cylinder lower bearings for looseness.</p> <p>5. Actuator assemblies for condition, leakage, and security.</p>		



SCHEDULED INSPECTIONS

5-9. 100 HOURS/12 CALENDAR MONTHS — PART A (CONT)

DATA REFERENCE	INSPECTION TASK DESCRIPTION	INITIAL	
		MECH	OTHER
Chapter 67	<p>6. Cylinder extension tubes for condition and security.</p> <p>7. Upper cylinder housing mounting bracket for condition and security. Check mounting bracket cavity for corrosion. Cavity drain hole for obstruction. Dust boot for condition. Reapply corrosion preventive compound (C-104) as required.</p> <p>8. Actuator linkage for wear and security.</p> <p>9. Clean exposed area of actuator piston with hydraulic fluid (C-002) or hydraulic fluid (C-072) and a clean lint-free cloth.</p> <p>10. Check cyclic and collective hydraulic cylinders piston rods for evidence of excessive wear and scoring. Wear of the piston rods indicates cylinder assembly is incorrectly aligned to lower supports and requires adjustment.</p> <p>— Restoration</p> <p>Every third 100 hour inspection (300 hours) or 12 months:</p> <p>1. Torque check nuts attaching actuator cylinder to upper supports.</p> <p>2. Remove bolts attaching actuator to lower supports. Check cylinder alignment to lower support. Rod end bearing side loads are not permitted. Reinstall bolts.</p> <p><u>TAIL ROTOR FLIGHT CONTROL ACTUATOR</u></p> <p>1. Tail rotor hydraulic actuator for leaks and security of attachment, mechanical damage, corrosion, and bearings and linkages for looseness.</p>		
Chapter 71	<p><u>POWER PLANT</u></p> <p>Every third 100 hour inspection (300 hours) or 12 months:</p> <p style="text-align: center;">NOTE</p> <p>If applicable, refer to BHT-212-SI-96 for installation of adjustable seals or refer to Chapter 71 for seal adjustment.</p>		



SCHEDULED INSPECTIONS

5-9. 100 HOURS/12 CALENDAR MONTHS — PART A (CONT)

DATA REFERENCE	INSPECTION TASK DESCRIPTION	INITIAL	
		MECH	OTHER
ASB 212-10-137 Chapter 71	<p>1. Inspect the left-hand and right-hand engine air inlet cowlings for gaps between the lower surface of the cowling firewall and the mating horizontal engine firewall.</p> <p><u>LEFT POWER SECTION</u></p> <p style="text-align: center;">NOTE</p> <p>Refer to Pratt & Whitney Canada PT6T-3/-3B Maintenance Manual for engine inspection requirements.</p> <p>Every third 100 hour inspection (300 hours) or 12 months:</p> <p>— Detailed Visual Inspection</p> <p>1. Ignition leads for corrosion, chafing and security.</p> <p>2. Chip detectors for debris.</p> <p>— Restoration</p> <p>1. Clean chip detectors.</p> <p>— Functional Check</p> <p>1. Test chip detectors electrical circuits.</p> <p><u>RIGHT POWER SECTION</u></p> <p style="text-align: center;">NOTE</p> <p>Refer to Pratt & Whitney Canada PT6T-3/-3B Maintenance Manual for engine inspection requirements.</p> <p>Every third 100 hour inspection (300 hours) or 12 months:</p> <p>— Detailed Visual Inspection</p> <p>1. Ignition leads for corrosion, chafing and security.</p> <p>2. Chip detectors for debris.</p>		



SCHEDULED INSPECTIONS

5-9. 100 HOURS/12 CALENDAR MONTHS — PART A (CONT)

DATA REFERENCE	INSPECTION TASK DESCRIPTION	INITIAL	
		MECH	OTHER
Chapter 76	<p>— Restoration</p> <p>1. Clean chip detectors.</p> <p>— Functional Check</p> <p>1. Test chip detectors electrical circuits.</p> <p><u>ENGINE FUEL AND POWER CONTROLS</u></p> <p>Every third 100 hour inspection (300 hours) or 12 months:</p> <p>— Operational Check</p> <p>1. Check controls for smooth movement through full travel ranges.</p>		
BHT-212-FM-1	<p>2. Check engine fuel control.</p>		
Chapter 71	<p><u>STARTER GENERATOR</u></p> <p>Every third 100 hour inspection (300 hours) or 12 months.</p> <p>— Detailed Visual Inspection</p> <p>1. Left power section starter generator cooling ducts for obstruction, kinking, and security.</p> <p>2. Right power section starter generator cooling ducts for obstruction, kinking, and security.</p> <p>3. Left power section starter generator brushes for allowable wear.</p> <p>4. Right power section starter generator brushes for allowable wear.</p>		
Chapter 76	<p><u>ENGINE CONTROLS</u></p> <p>1. Deleted.</p>		



SCHEDULED INSPECTIONS

5-9. 100 HOURS/12 CALENDAR MONTHS — PART A (CONT)

DATA REFERENCE	INSPECTION TASK DESCRIPTION	INITIAL	
		MECH	OTHER
Chapter 71	<p>Every third 100 hour inspection (300 hours) or 12 months:</p> <ol style="list-style-type: none"> 1. Engine fuel and power controls: <ol style="list-style-type: none"> a. Engine control linkages for looseness, lost motion, chafing, damage, and security of attachment. b. Bellcranks, mounts, and jackshafts for looseness, damage, and security of attachment. <p>Every sixth 100 hour inspection (600 hours) or 12 months:</p> <ol style="list-style-type: none"> 1. Perform maximum N_G topping check. <p><u>COMBINING (REDUCTION) GEARBOX</u></p> <p style="text-align: center;">NOTE</p> <p style="text-align: center;">Refer to Pratt & Whitney Canada PT6T-3/-3B Maintenance Manual for engine inspection requirements.</p> <p>Every third 100 hour inspection (300 hours) or 12 months:</p> <p>— Detailed Visual Inspection</p> <ol style="list-style-type: none"> 1. Chip detectors for debris. <p>— Restoration</p> <ol style="list-style-type: none"> 1. Clean chip detectors. <p>— Functional Check</p> <ol style="list-style-type: none"> 1. Test chip detectors electrical circuits. 		
Chapter 95	<p><u>INSTRUMENTS</u></p> <p style="text-align: center;">NOTE</p> <p style="text-align: center;">The following checks are required every 12 months only.</p>		



SCHEDULED INSPECTIONS

5-9. 100 HOURS/12 CALENDAR MONTHS — PART A (CONT)

DATA REFERENCE	INSPECTION TASK DESCRIPTION	INITIAL	
		MECH	OTHER
Chapter 96	<ol style="list-style-type: none"> 1. Calibrate pilot and copilot compass systems and standby magnetic compass. 2. Drain pitot-static system of any accumulated moisture. 3. Test pitot-static system for leaks. <p><u>ELECTRICAL SYSTEM</u></p> <ol style="list-style-type: none"> 1. Check inverters for security of mounting and connections. 2. Check generator control units for damage and security of mounting and terminals. 3. All exposed wire bundles, bundle supports and connectors for damage, corrosion, and security. Pay particular attention to engine deck connectors and harnesses. 4. Inspect relays and main bus area for security of mounting and connections. 5. Inspect bus insulation for damage and condition. 6. Deleted. 		
Chapter 96	<p><u>BATTERY SYSTEM</u></p> <ol style="list-style-type: none"> 1. Deleted. 2. Inspect battery compartment for general condition. 3. Check battery mount for security and corrosion. 		
Chapter 96	<p><u>POWER DIODES</u></p> <p>Every third 100 hour inspection (300 hours) or 12 months:</p> <ol style="list-style-type: none"> 1. Perform functional check of power diodes. 		

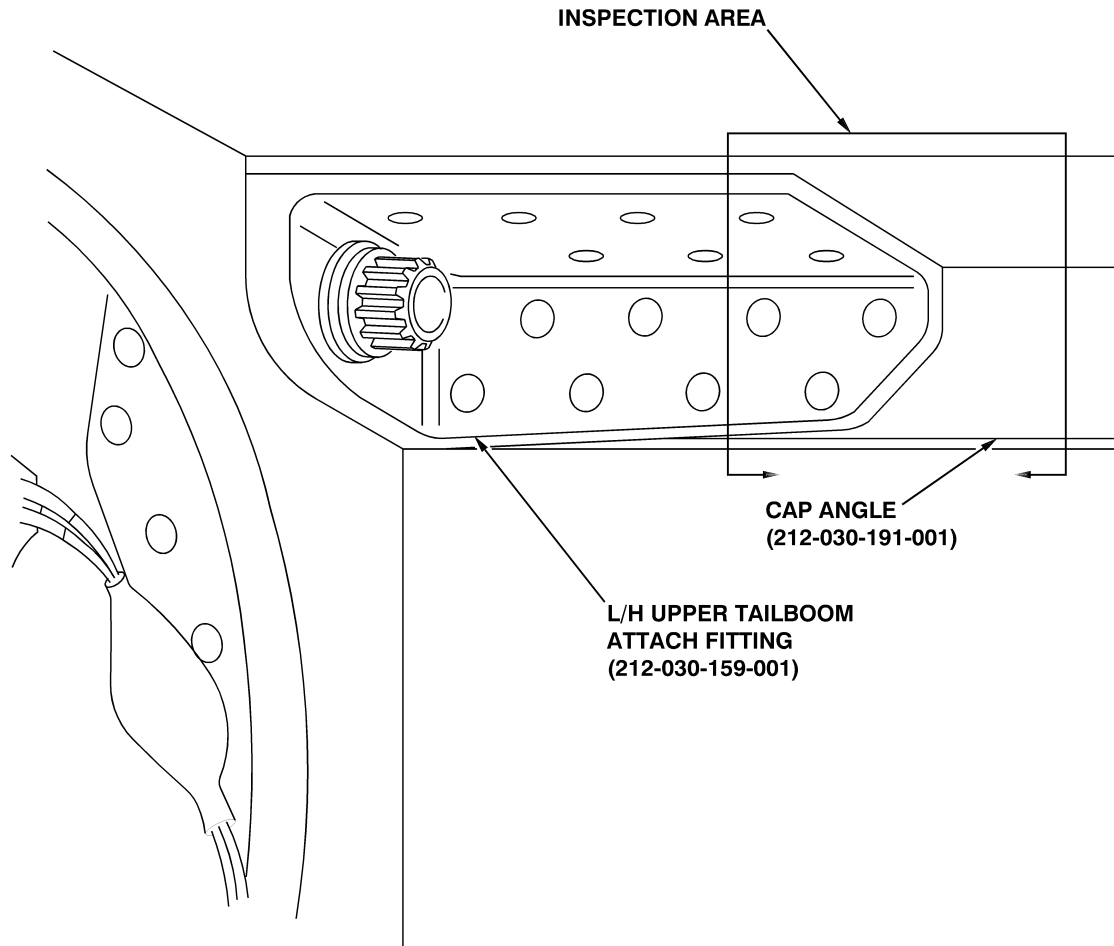
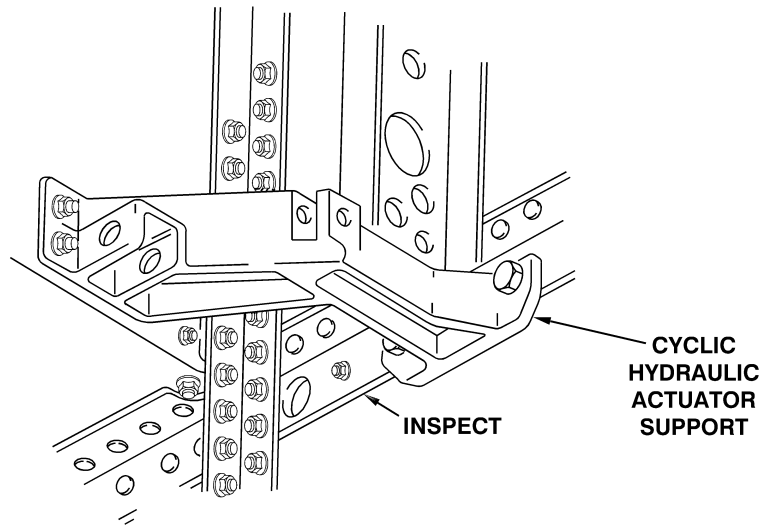
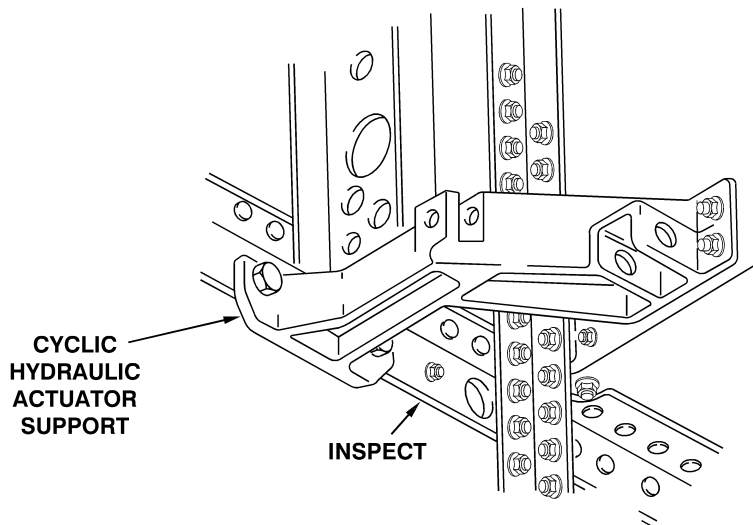

Figure 5-1. Fuselage Tailboom Attachment Inspection

212_MM_05_0003



**DETAIL A
RIGHT SIDE**



**DETAIL B
LEFT SIDE**

**VIEW LOOKING UP INTO
CARGO HOOK OPENING**

Figure 5-2. Inspection of Beam Caps

212_MM_05_0001



SCHEDULED INSPECTIONS

5-10. 1000 HOURS — PART A

DATA REFERENCE	INSPECTION TASK DESCRIPTION	INITIAL MECH OTHER	
<p>Chapter 12</p> <p>Chapter 62</p>	<p>DATE: _____ W.O. _____</p> <p>FACILITY: _____</p> <p>HELICOPTER S/N: _____</p> <p>REGISTRY NO.: _____</p> <p>TOTAL TIME: _____</p> <p>SIGNATURE: _____</p> <p style="text-align: center;">NOTE</p> <p>For helicopters on the Part A inspection program, accomplish the following checks each 1000 hours of flight operation.</p> <p><u>GENERAL</u></p> <p>— Instruction</p> <ol style="list-style-type: none"> Each listed inspection item or maintenance function is to be performed in accordance with this Maintenance Manual. All work accomplished during the inspection shall be recorded in the helicopter maintenance record. Deleted. Refer to Lubrication Chart (Chapter 12) for 1000 hour requirements. <p><u>SWASHPLATE AND SUPPORT ASSEMBLY — SCISSORS AND SLEEVE ASSEMBLY</u></p> <ol style="list-style-type: none"> Inspect swashplate and support assembly, and scissors and sleeve assembly. 		

SCHEDULED INSPECTIONS

5-10. 1000 HOURS — PART A (CONT)

DATA REFERENCE	INSPECTION TASK DESCRIPTION	INITIAL	
		MECH	OTHER
	<ol style="list-style-type: none"> 2. Disconnect bottom of each drive link from swashplate trunnion and each mixing lever control tube from scissors. 3. Check swashplate duplex bearing and collective sleeve hub bearing set for roughness and ease of rotation. 4. Purge lubricate bearings. 5. Reconnect drive links and tubes. 		



SCHEDULED INSPECTIONS

5-11. 5000 HOURS/5 YEARS INSPECTION — PART A

DATA REFERENCE	INSPECTION TASK DESCRIPTION	INITIAL	
		MECH	OTHER
<p>Chapter 96</p> <p>Chapter 97</p>	<p>DATE: _____ W.O. _____</p> <p>FACILITY: _____</p> <p>HELICOPTER S/N: _____</p> <p>REGISTRY NO.: _____</p> <p>TOTAL TIME: _____</p> <p>SIGNATURE: _____</p> <p style="text-align: center;">NOTE</p> <p>For helicopters on the Part A inspection program, accomplish each 5000 hours flight time or 60 months, whichever comes first.</p> <p>This inspection is meant to be a full visual inspection of the airframe primarily for environmental damage and corrosion.</p> <p><u>GENERAL</u></p> <p>Each listed inspection item or maintenance function is to be performed in accordance with the BHT-212-MM chapter specified or the BHT-212-CR&O.</p> <p><u>PRELIMINARY REQUIREMENTS</u></p> <p>1. All work accomplished during this inspection shall be recorded in the helicopter maintenance records.</p> <p>2. Remove all panels, interior coverings, fairings, and cowlings required to satisfactorily carry out the inspection.</p> <p>3. Remove the following items:</p> <p style="padding-left: 20px;">a. Main battery.</p> <p style="padding-left: 20px;">b. Electrical and avionics equipment from the nose area, as required, to allow a full visual inspection of the nose area to be done.</p>		



SCHEDULED INSPECTIONS

5-11. 5000 HOURS/5 YEARS INSPECTION — PART A (CONT)

DATA REFERENCE	INSPECTION TASK DESCRIPTION	INITIAL	
		MECH	OTHER
Chapter 62	c. Main rotor transmission.		
Chapter 65	d. Intermediate gearbox.		
Chapter 64	e. Tail rotor gearbox.		
Chapter 53	f. Tailboom (to allow a full inspection of the aft fuselage bulkhead and forward tailboom bulkhead).		
Chapter 32	g. Landing gear assembly (to allow a complete inspection of the landing gear attachment points and support structure).		
	<p>4. In addition to the 5000 Hour/5 Year Inspection — Part A items, carry out the following:</p> <p>a. Complete Daily Inspection — Part A.</p> <p>b. Complete 100 Hour/12 Month Inspection — Part A.</p> <p>c. Complete 1000 Hour Inspection — Part A.</p> <p><u>AFTER COMPLETION OF INSPECTION</u></p> <p>1. Install the following items:</p> <p>a. Main battery.</p> <p>b. Electrical and avionics equipment on the nose area.</p> <p>c. Main rotor transmission.</p> <p>d. Intermediate gearbox.</p> <p>e. Tail rotor gearbox.</p> <p>f. Tailboom.</p> <p>g. Landing gear assembly.</p> <p>2. Install all panels, interior coverings, fairings, and cowlings removed during inspection.</p>		
Chapter 96	a. Main battery.		
Chapter 97	b. Electrical and avionics equipment on the nose area.		
Chapter 62	c. Main rotor transmission.		
Chapter 65	d. Intermediate gearbox.		
Chapter 64	e. Tail rotor gearbox.		
Chapter 53	f. Tailboom.		
Chapter 32	g. Landing gear assembly.		
	2. Install all panels, interior coverings, fairings, and cowlings removed during inspection.		



SCHEDULED INSPECTIONS

5-11. 5000 HOURS/5 YEARS INSPECTION — PART A (CONT)

DATA REFERENCE	INSPECTION TASK DESCRIPTION	INITIAL	
		MECH	OTHER
Chapter 53	<p>3. Do a ground run and leak check before you return the helicopter to service.</p> <p><u>FORWARD FUSELAGE</u></p> <p>1. Nose panels in area of pitot tube attachment, areas inside and outside for disbonding and cracking.</p> <p>2. Pitot tubes attachment for looseness.</p> <p>3. Nose shelves for damage, corrosion, and disbonding.</p> <p>4. Nose shelf attachment locations for damage, corrosion, and cracking.</p> <p>5. Right and left BL 14.00 main beams, forward of STA 23.00 for damage, corrosion, and cracking.</p> <p>6. Instrument panel attachment structure for damage, corrosion, and cracking, primarily in the door frame attachment area.</p> <p>7. Instrument panel glareshield for chafing and cracking.</p> <p>8. Crew door hinge attachment structure for damage and cracks.</p> <p>9. Outboard cabin post (1, Figure 5-2A), cabin roof longeron (2), and windshield frame (5) upper corner area for damage and cracks.</p> <p>10. Striker plates (3 and 4) attachment areas for damage and cracks.</p> <p>11. Striker plates (3 and 4) for excessive wear, damage, and corrosion.</p> <p>12. Cabin floor area under crew doors for chafing and damage.</p> <p>13. Crew door hinges for wear, damage, corrosion, and security of attachment.</p> <p>14. Crew doors for proper fit and operation.</p>		



SCHEDULED INSPECTIONS

5-11. 5000 HOURS/5 YEARS INSPECTION — PART A (CONT)

DATA REFERENCE	INSPECTION TASK DESCRIPTION	INITIAL	
		MECH	OTHER
	<p>15. Crew seat rails for excessive wear and damage.</p> <p>16. Center and outboard bulkhead, below WL 22.00 at FS 23.00, for cracks, deformation, and corrosion along structure joints.</p> <p>17. Collective and cyclic control jackshafts support intercostals for cracks and corrosion.</p> <p>18. Cyclic support for corrosion and cracks.</p> <p>19. Collective, cyclic, and antitorque control system bellcranks, levers, and support brackets for corrosion, cracks, and indication of wear at attaching points.</p> <p>20. Crew seat support beams, at BL 14.00 and 30.00 between FS 23.00 and 74.30, for cracks and corrosion.</p> <p>21. Forward crosstube attachment points and support structure at FS 63.33 and 74.30 for damage, corrosion, and cracks.</p> <p>22. Aft crosstube attachment points and support structure at FS 155.06 and 166.00 for damage, corrosion, and cracks.</p> <p>23. Crew and passenger cabin floor, FS 23.00 to 155.06, for corrosion and damage. Floor bonded panels for voids. Seat fasteners and cargo tie-down rings for condition. Area around pilot and copilot ICS foot switches for cracks.</p> <p style="text-align: center;">NOTE</p> <p style="text-align: center;">In the following step, removal of the fuel cells is not required unless there is evidence of fuel leakage or damage to the fuel cells or structure is suspected.</p> <p>24. All structure under floor panels and in forward fuel cell cavities including caps, angles, transverse bulkheads, and bonded panels between FS 74.30 and 155.06 for damage, corrosion, cracks, and voids.</p>		



SCHEDULED INSPECTIONS

5-11. 5000 HOURS/5 YEARS INSPECTION — PART A (CONT)

DATA REFERENCE	INSPECTION TASK DESCRIPTION	INITIAL	
		MECH	OTHER
	<p style="text-align: center;">NOTE</p> <p>In the following step, removal of the fuel cells is not required unless there is evidence of fuel leakage or damage to the fuel cells or structure is suspected. Structure that is hidden by the fuel cells only needs to be inspected if the fuel cells are removed for some reason or structural damage is suspected.</p> <p>25. All structure under floor panels and in aft fuel cell cavities including caps, angles, and panels between FS 155.06 and 200.00 for damage, corrosion, cracks, and disbonding.</p> <p>26. Bottom skin, FS 23.00 to 243.937, for damage. Joints for corrosion. Access panels and covers for condition and attachment.</p> <p>27. Main transmission compartment interior, FS 129.00 to 166.00 and WL 7.44 to 76.00, for corrosion. Bulkheads and main beam panels for damage and corrosion. Attaching supports and brackets for condition and security.</p> <p>28. Fluid lines in transmission compartment for evidence of leaks, condition, wear, and chafing. Clamps for condition (fluid contamination and swelling) and security of attachment.</p> <p>29. Lift beam fitting for condition and working rivets, lift link attachment bolt hole bores for excessive wear, and bushings for looseness.</p> <p>30. Pylon (transmission) support structure for wear and cracks. Pay particular attention to right and left horizontal supports, forward vertical supports, and aft vertical webs.</p> <p>31. Aft cabin bulkheads, FS 166.00, for damage, upper aft flange for cracks, and bulkhead panel for damage and disbonding.</p> <p>32. Electrical/avionics compartment, FS 166.00 to 243.937, doors for condition and security. Door frames for cracks and corrosion. Compartment interior for condition and joints for corrosion. Skin for damage and cracks.</p>		



SCHEDULED INSPECTIONS

5-11. 5000 HOURS/5 YEARS INSPECTION — PART A (CONT)

DATA REFERENCE	INSPECTION TASK DESCRIPTION	INITIAL	
		MECH	OTHER
Chapter 53	<p>33. Oil cooler compartment, FS 166.00 to 243.937, doors for condition and security. Main beam panels and bulkheads for condition and corrosion.</p> <p>34. Engine deck below the reduction gearbox, FS 211.00 to 238.00 for damage, cracks, and disbonding.</p> <p>35. Firewalls, FS 155.06 to 241.22, for damage, cracks, security of attachment, seals for condition, and seal attachment angles for cracks.</p> <p>36. Cabin roof, FS 35.00 to 166.00 above WL 68.00, BL 50.00 left and right side, for damaged skin and joints for corrosion, bonded panels for disbonding and corrosion. Structure above overhead console (circuit breaker panels) for cracks and corrosion.</p> <p>37. Cargo door tracks for wear, cracks, and corrosion.</p> <p>38. Engine and transmission cowlings and fairings for evidence of chafing, cracks, corrosion, and seals for condition.</p> <p>39. Bulkhead, FS 241.22, for damage, corrosion, and cracks. Tailboom attachment fittings for damage, cracks, and loose fasteners. Tailboom attachment bolt holes for damage and corrosion.</p> <p>40. Tailboom attachment bolts for damage, wear, and corrosion.</p> <p><u>TAILBOOM</u></p> <p>1. Bulkhead, BS 17.42, for corrosion and cracks. Fuselage attachment bolt holes for damage and corrosion. Barrel nuts for damage and corrosion.</p> <p>2. Tailboom and fin driveshaft covers for condition and attachment.</p> <p>3. Tailboom and fin external skin for damage, corrosion, and cracks.</p> <p>4. Tailboom access panels and covers for condition and attachment. Tail rotor driveshaft cover hinges for wear.</p>		

**SCHEDULED INSPECTIONS****5-11. 5000 HOURS/5 YEARS INSPECTION — PART A (CONT)**

DATA REFERENCE	INSPECTION TASK DESCRIPTION	INITIAL	
		MECH	OTHER
	<p>5. Tailboom baggage compartment door for condition, attachment, and door handle operation.</p> <p>6. Tailboom baggage compartment interior for damage, panels for disbonding, and corrosion. Longerons above roof panel for corrosion and cracks. Longerons below floor panel for corrosion and cracks.</p> <p>7. Tailboom interior bulkheads and stringers for cracks and corrosion.</p> <p>8. Intermediate gearbox mount pad for damage, cracks, fretting, and corrosion.</p> <p>9. Tail rotor gearbox support fitting assembly for damage, cracks, fretting, and corrosion. Pay particular attention to mounting holes and lugs.</p> <p>10. Tailboom exterior bonded panels adjacent to baggage compartment for damage, delamination, and corrosion.</p> <p>11. With a borescope or equivalent, inspect interior structure of vertical fin for cracks, corrosion, fretting, and damage.</p> <p>12. Control tube fairleads (grommets and guides) for wear and security of attachment.</p>		

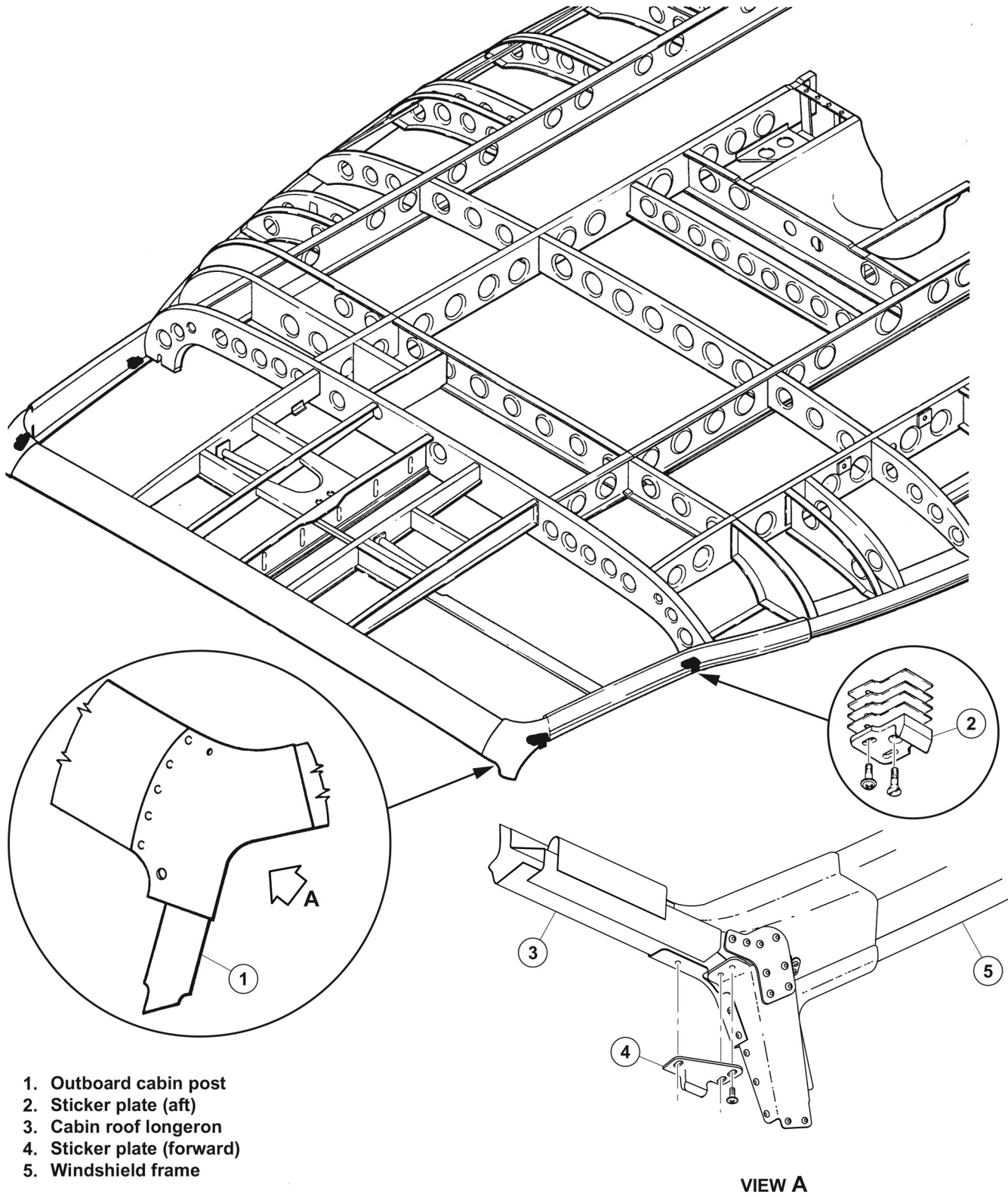

- 1. Outboard cabin post
- 2. Sticker plate (aft)
- 3. Cabin roof longeron
- 4. Sticker plate (forward)
- 5. Windshield frame

VIEW A

212_MM_05_0002a

Figure 5-2A. Cabin Frame Inspection — Part A

SCHEDULED INSPECTIONS

5-12. 25 HOURS/30 DAYS — PART B

DATA REFERENCE	INSPECTION TASK DESCRIPTION	INITIAL	
		MECH	OTHER
	<p>DATE: _____ W.O. _____</p> <p>FACILITY: _____</p> <p>HELICOPTER S/N: _____</p> <p>REGISTRY NO.: _____</p> <p>TOTAL TIME: _____</p> <p>SIGNATURE: _____</p> <p style="text-align: center;">NOTE</p> <p>For helicopters on the Part B inspection program, accomplish the following checks each 25 hours of flight operation or 30 days, whichever occurs first.</p> <p><u>GENERAL</u></p> <p>1. Each listed inspection item or maintenance function is to be performed in accordance with the referenced Maintenance Manual chapter specified or BHT-212-CR&O manual.</p> <p>2. Refer to Pratt & Whitney Canada PT6T-3/-3B Maintenance Manual for engine inspection requirements.</p> <p><u>PRELIMINARY REQUIREMENTS</u></p> <p>1. Use medium helicopter corrosion control guide to establish helicopter corrosion control program.</p> <p>2. Replace all finite life components that have completed published operating limitations.</p> <p>3. Overhaul all components that have completed published overhaul periods.</p> <p>4. Lubricate and service helicopter as required.</p>		
CSSD-PSE-87-001	1. Use medium helicopter corrosion control guide to establish helicopter corrosion control program.		
Chapter 4	2. Replace all finite life components that have completed published operating limitations.		
Chapter 5	3. Overhaul all components that have completed published overhaul periods.		
Chapter 12	4. Lubricate and service helicopter as required.		



SCHEDULED INSPECTIONS

5-12. 25 HOURS/30 DAYS — PART B (CONT)

DATA REFERENCE	INSPECTION TASK DESCRIPTION	INITIAL	
		MECH	OTHER
Chapter 5	<p>5. Review Special Inspections and carry out applicable inspections.</p> <p>6. Examine all inspection windows and sight glasses for cracking, crazing, and discoloration. If any of these conditions are present the part must be removed and replaced prior to returning helicopter to service.</p>		
Service Instructions (SI)	<p>7. Make sure that all the required inspections of installed BHT kits are not covered in this inspection have been performed, as applicable.</p> <p style="text-align: center;"><u>FUSELAGE — NOSE SECTION</u></p>		
Chapter 95	1. Pitot tubes and static ports for visible obstruction and damage.		
Chapter 52	2. Nose doors for damage, corrosion, security of attachment, and missing or damaged twist fasteners, seal for condition.		
Chapter 53	<p>3. Fuselage:</p> <p style="padding-left: 40px;">a. Forward fuselage area structure and skin for damage, corrosion, cleanliness, and damage to protective finish.</p> <p style="padding-left: 40px;">b. Avionics and electrical compartment for water entrapment.</p>		
Chapter 96	<p>4. Battery installation:</p> <p style="padding-left: 40px;">a. Battery and external connections for security, corrosion, and condition.</p> <p style="padding-left: 40px;">b. Battery vent and drain tubes are unobstructed.</p> <p style="padding-left: 40px;">c. Every fourth 25 hour/30 day inspection (100 hours) check battery mounts for corrosion and service battery in accordance with battery manufacturer's recommendation.</p>		
Chapter 96	5. Electrical equipment for condition, corrosion, and security.		
Chapter 97	6. Avionics equipment for condition and security.		
Chapter 52	7. All windows for damage and cleanliness.		



SCHEDULED INSPECTIONS

5-12. 25 HOURS/30 DAYS — PART B (CONT)

DATA REFERENCE	INSPECTION TASK DESCRIPTION	INITIAL	
		MECH	OTHER
Chapter 30	8. Windshield wiper arms and blades for serviceability and security.		
Chapter 29	9. Remote hydraulic filter bypass indicator — check for bypass indication.		
Chapter 97	10. Antennas for condition and security.		
Chapter 52	11. Crew doors (and surrounding structure) for damage, corrosion, and proper operation, emergency release pins for security.		
	<u>FUSELAGE — CABIN SECTION</u>		
Chapter 53	1. Fuselage structure and compartments for condition, corrosion, water entrapment, and damage to protective finish.		
Chapter 53	2. Fuselage underside for evidence of fuel and hydraulic fluid leakage.		
Chapter 28	3. Visually inspect fuel samples for contamination.		
Chapter 32	4. Landing gear system: <p>a. Forward crosstube assembly and retention caps for condition and security of attachment.</p> <p>b. Aft crosstube assembly and retention caps for condition and security of attachment.</p> <p>c. Skid tubes and skid shoes for condition and security of attachment. Replace skid shoes that are worn into shoe surface. Repair weld beads as required.</p> <p>d. Fuselage supports for wear, damage, and security of attachment.</p> <p>e. If installed, landing gear forward crosstube crew step fittings for corrosion, damage, and security in area of attachment. If edge sealant is damaged or missing, remove crew step and inspect crosstube for corrosion or damage.</p> <p>f. Emergency float reservoir pressure indicator for proper charge indication (if installed).</p>		

SCHEDULED INSPECTIONS

5-12. 25 HOURS/30 DAYS — PART B (CONT)

DATA REFERENCE	INSPECTION TASK DESCRIPTION	INITIAL	
		MECH	OTHER
Chapter 96	<p>g. Floats for proper stowage and condition (if installed).</p> <p>5. Landing light and searchlight for condition and security.</p>		
Chapter 97	<p>6. Antennas for damage, cleanliness, and security.</p>		
Chapter 52	<p>7. Passenger/cargo doors and surrounding structure for damage, corrosion, and proper operation. Window seals for condition.</p>		
Chapter 25	<p>8. Crew seats:</p> <p>a. Seats for condition, security, and proper operation.</p> <p>b. Cushions and backs for cleanliness, excessive deterioration, and tears.</p> <p>c. Crew seat restraint assemblies for condition, security, and proper operation.</p>		
Chapter 25	<p>9. Passenger seats:</p> <p>a. Seats for condition and security.</p> <p>b. Cushions and backs for cleanliness, excessive deterioration, and tears.</p> <p>c. Passenger seat restraint assemblies for condition, security, and proper operation.</p>		
Chapter 95	<p>10. Instruments:</p> <p>a. Instrument panel for cleanliness.</p> <p>b. All instrument, placards, decals, and markings for appearance and legibility.</p> <p>c. Check magnetic compass for condition and security.</p> <p>d. All compass cards for validity.</p>		

SCHEDULED INSPECTIONS

5-12. 25 HOURS/30 DAYS — PART B (CONT)

DATA REFERENCE	INSPECTION TASK DESCRIPTION	INITIAL	
		MECH	OTHER
Chapter 96 and Chapter 97	<p>11. Avionics and electrical equipment:</p> <p>a. Pedestal mounted avionics/electrical equipment for condition, cleanliness, and security.</p> <p>b. Overhead console for condition, cleanliness, and security.</p> <p>c. All instrument lights, integrally lit panels, secondary lights, and map lights for serviceability.</p> <p>d. All caution and warning lights for proper operation by using master caution, fire test, and baggage compartment smoke detector. Press to test functions.</p> <p>e. Deleted.</p> <p>f. Navigation and anticollision lights for condition and security.</p> <p>g. Every fourth 25 hour/ 30 day inspection operationally check cabin heater system, bleed air shutoff and line check valve.</p>		
Chapter 26	<p>12. Two portable fire extinguishers for condition, mounting, and valid inspection certificate.</p>		
Chapter 21	<p>13. Cabin heating and ventilation system:</p> <p>a. Ventilating system components for condition and security.</p> <p>b. Heat/vent air ducts for condition and proper operation.</p> <p>c. Ventilation/defog components for condition and security.</p>		
Chapter 25	<p>14. Miscellaneous furnishings (map and data case, first aid kit, and emergency equipment) for condition and security.</p>		
Chapter 63	<p>15. Main rotor transmission:</p> <p>a. Proper oil level.</p>		

SCHEDULED INSPECTIONS

5-12. 25 HOURS/30 DAYS — PART B (CONT)

DATA REFERENCE	INSPECTION TASK DESCRIPTION	INITIAL MECH OTHER	
Chapter 29	<p>b. External oil filter for bypass indication.</p> <p>c. Cases for damage, corrosion, condition, and evidence of leakage.</p> <p>d. Accessories for condition, corrosion, damage, and security of attachment.</p> <p>e. External oil lines and hoses for condition, damage, chafing, and leaks, paying particular attention to lines running aft of the thermostatic relief valve.</p> <p>f. Transmission mount dust boots for condition.</p> <div style="text-align: center; margin: 10px 0;">  <p>WARNING</p> </div> <p>CAUSE OF ANY DISCOLORATION SHALL BE DETERMINED AND CORRECTED PRIOR TO NEXT FLIGHT.</p> <p>g. Transmission tail rotor output quill coupling and surrounding area for grease leakage, damage, corrosion, and evidence of overheat as indicated by TEMP-PLATES or coupling discoloration. A change in color of one or more of the red bordered TEMP-PLATE dots from white/off-white to black, indicates an overheat condition, and may require replacement of both outer and inner couplings (step h).</p> <p>h. Overheat TEMP-PLATES for condition and security. TEMP-PLATES must not show evidence of overtemperature indication, deterioration, debonding, or excessive discoloration of the epoxy overcoating.</p> <p>16. Hydraulic systems:</p> <p>a. Hydraulic system 1 and 2 filter bypass indicator buttons are not extended.</p> <p>b. Collective and cyclic servo actuators for leaks, corrosion, damage, and security.</p>		

SCHEDULED INSPECTIONS

5-12. 25 HOURS/30 DAYS — PART B (CONT)

DATA REFERENCE	INSPECTION TASK DESCRIPTION	INITIAL	
		MECH	OTHER
Chapter 52	<p>c. Hydraulic system 1 pump for leaks, damage, and security.</p> <p>d. Hydraulic system 1 and 2 valve and filter modules for leaks, damage, and security.</p> <p>e. Hydraulic system 1 and 2 lines, hoses, and fittings for leaks, damage, chafing, kinking, and security.</p> <p><u>CENTER FUSELAGE</u></p> <p style="text-align: center;">NOTE</p> <p>Accomplish the following checks every fourth 25 hour/30 day inspection.</p> <p>Lower cyclic hydraulic actuator supports P/N 212-030-826-001 and -002 in cargo hook compartment (hellhole).</p> <p style="text-align: center;">NOTE</p> <p>The following inspection is not required for helicopters S/N 30790 and subsequent and helicopters modified in accordance with TB 212-76-12.</p> <ol style="list-style-type: none"> 1. Clean area around fuel vent line hole with MEK (C-309) and remove finish from beam cap. 2. Inspect each beam cap for hairline cracks using a bright light. Inspect inboard side of left and right main beams around fuel vent line that goes through cap extrusion at FS 131.00, WL 21.50, and BL 14.00. Pay particular attention to first high shear rivet hole above WL 22.00 at FS 129.00 (Figure 5-2, Detail A and Detail B). 3. Apply clear lacquer over cleaned area. <p><u>FUSELAGE AFT OF CABIN LEFT AND RIGHT SIDE</u></p> <ol style="list-style-type: none"> 1. Avionics/electrical and heater compartment doors for condition and security of attachment. Latches for proper operation. 		

SCHEDULED INSPECTIONS

5-12. 25 HOURS/30 DAYS — PART B (CONT)

DATA REFERENCE	INSPECTION TASK DESCRIPTION	INITIAL	
		MECH	OTHER
Chapter 53	<p>2. Fuselage structure:</p> <p style="padding-left: 40px;">a. Avionics/electrical and heater compartments for evidence of water entrapment.</p> <p style="padding-left: 40px;">b. Engine decks for condition and evidence of delamination.</p>		
Chapter 96 and Chapter 97	3. Avionics and electrical equipment for security and condition.		
Chapter 21	4. Heater compartment for cleanliness, condition, and security of heating system components, wiring, ducts, and supports. Structure for damage and corrosion including connections and fasteners.		
Chapter 29	5. Tail rotor hydraulic actuator and hoses for leakage, corrosion, and security.		
Chapter 67	6. Tail rotor control tubes for condition, corrosion, and security.		
Chapter 63	<p>7. Transmission oil cooling system:</p> <p style="padding-left: 40px;">a. Oil coolers for leakage, damage, and obstruction.</p> <p style="padding-left: 40px;">b. Oil cooler hoses and tubes for leakage, damage, chafing, and fraying.</p> <p style="padding-left: 40px;">c. Oil cooler blowers for damage, corrosion, and obstruction.</p>		
Chapter 79	<p>8. Engine oil system:</p> <p style="padding-left: 40px;">a. Oil coolers for leakage, corrosion, damage, and obstruction.</p> <p style="padding-left: 40px;">b. Oil cooler hoses and tubes for leakage, damage, chafing, and fraying.</p> <p style="padding-left: 40px;">c. Reduction gearbox oil filter impending bypass indicator button is not extended.</p> <p style="padding-left: 40px;">d. Power section 1 for proper oil level.</p>		



SCHEDULED INSPECTIONS

5-12. 25 HOURS/30 DAYS — PART B (CONT)

DATA REFERENCE	INSPECTION TASK DESCRIPTION	INITIAL	
		MECH	OTHER
Chapter 26	<ul style="list-style-type: none"> e. Power section 2 for proper oil level. f. Reduction gearbox for proper oil level. g. Engine accessory and reduction gearbox for oil leaks. 		
Chapter 71	<p>9. Engine compartment fire extinguisher containers for proper charge, condition, and mounting.</p>		
Chapter 71	<p>10. Engine and reduction gearbox mounts for loose bearings and security.</p>		
Chapter 71	<p>11. No. 1 (left) engine power section:</p> <ul style="list-style-type: none"> a. Exhaust ejector and duct for damage and security. b. Gas generator case for cracks, buckled areas, and hot spots. c. Oil and fuel hoses and tubes for chafing, leaking, and security. d. Electrical wiring for fraying, chafing, and security. 		
Chapter 71	<p>12. No. 2 (right) engine power section:</p> <ul style="list-style-type: none"> a. Exhaust ejector and duct for damage and security. b. Gas generator case for cracks, buckled areas, and hot spots. c. Oil and fuel hoses and tubes for chafing, leaking, and security. d. Electrical wiring for fraying, chafing, and security. 		
Chapter 71	<p>13. Engine firewalls, air intake ducts, and plenum for cracks, distortion, missing rivets, broken spots welds, and deteriorating seals or gaskets.</p>		
Chapter 71	<p>14. Engine cowling for missing fasteners and cracks. Latches for proper operation.</p>		

SCHEDULED INSPECTIONS

5-12. 25 HOURS/30 DAYS — PART B (CONT)

DATA REFERENCE	INSPECTION TASK DESCRIPTION	INITIAL	
		MECH	OTHER
Chapter 53	<p><u>FUSELAGE AFT TAILBOOM ATTACHMENT</u></p> <p>1. Inspect fuselage tailboom attachment points for security.</p> <p>2. Every fourth 25 hour/30 day inspection:</p> <p style="padding-left: 40px;">a. Inspect fuselage and tailboom attachment components and hardware for cracks with 10X magnifying glass. Pay particular attention to interface between forward end of tailboom attachment fitting and cap angle (Figure 5-1).</p> <p><u>TAILBOOM</u></p>		
Chapter 53	<p>1. Tailboom structure:</p> <p style="padding-left: 40px;">a. Exterior structure for condition, damage, and corrosion.</p> <p style="padding-left: 40px;">b. Baggage compartment interior for condition and cleanliness.</p>		
Chapter 52	<p>2. Baggage compartment door for damage, proper operation, and security.</p>		
Chapter 52	<p>3. Driveshaft and intermediate gearbox covers for damage and security.</p>		
Chapter 67	<p>4. Elevators for damage and security.</p>		
Chapter 97	<p>5. Tailboom mounted avionics equipment for condition and security.</p>		
Chapter 53	<p>6. Every fourth 25 hour/30 day inspection:</p>		
ASB 212-00-110	<p style="padding-left: 40px;">a. Inspect vertical fin caps for cracks and/or corrosion.</p> <p style="padding-left: 40px;">b. Inspect interior structure (including joints, splices, longerons, attach fittings and hardware) for condition, corrosion, damage, and cracks.</p>		
Chapter 67	<p style="padding-left: 40px;">c. Check elevator attachment lugs at each end of elevator horn for cracks, corrosion, and security.</p>		





SCHEDULED INSPECTIONS

5-12. 25 HOURS/30 DAYS — PART B (CONT)

DATA REFERENCE	INSPECTION TASK DESCRIPTION	INITIAL	
		MECH	OTHER
Chapter 65	<p>d. Check elevator horn to elevator spar attaching bolts and surrounding joint for cracks, corrosion, and security.</p> <p>e. Check elevator control tubes, supports, attaching hardware, and surrounding structure for corrosion, damage, and security.</p> <p>f. Torque check tail rotor gearbox mounting nuts by applying torque in tightening direction, do not exceed 200 inch-pounds (22.6 Nm). If any nut rotates under torque, inspect attachment hardware and tail rotor gearbox for serviceability.</p> <p>g. Torque check intermediate gearbox mounting bolts by applying torque in tightening direction, do not exceed 50 inch-pounds (5.65 Nm). If any bolt turns under torque, inspect attachment hardware and intermediate gearbox for serviceability.</p>		
Chapter 65	<p>7. Tail rotor driveshaft:</p> <div style="text-align: center; margin: 10px 0;">  <p>WARNING</p> </div> <p>THE CAUSE OF ANY DISCOLORATION SHALL BE DETERMINED AND CORRECTED PRIOR TO NEXT FLIGHT.</p> <p>a. Hanger assemblies — bearings and surrounding areas for evidence of grease leakage, condition, damage, security, corrosion, and overheating. Discoloration of bearing (color change to blue or blue/black) or multi-color appearance of hanger that darkens adjacent to bearing is evidence of overheating. Brown color of bearing shield is normal and is not evidence of overheating.</p> <p>b. Driveshaft sections for cracks, rivet failure, distortion, dents, corrosion, and damage to anodized finish.</p> <p>c. Clamp sets for condition, security, and proper installation.</p>		

SCHEDULED INSPECTIONS

5-12. 25 HOURS/30 DAYS — PART B (CONT)

DATA REFERENCE	INSPECTION TASK DESCRIPTION	INITIAL MECH OTHER	
Chapter 65	<div style="text-align: center; margin-bottom: 20px;">  <p>WARNING</p> </div> <p>THE CAUSE OF ANY DISCOLORATION SHALL BE DETERMINED AND CORRECTED PRIOR TO NEXT FLIGHT.</p> <p>d. Flexible couplings and surrounding areas for grease leakage, damage, corrosion, and evidence of overheat as indicated by TEMP-PLATES or coupling discoloration. A change in color of one or more of the red bordered TEMP-PLATE dots from white/off-white to black indicates an overheat condition and may require replacement of both outer and inner couplings (step e).</p> <p>e. Overheat TEMP-PLATES for condition and security. TEMP-PLATES must not show evidence of over temperature indication, deterioration, debonding, or excessive discoloration of the epoxy overcoating.</p> <p>8. Intermediate gearbox:</p> <p>a. Gearbox assembly for security, condition, corrosion, damage, and oil leaking.</p> <div style="text-align: center; margin-top: 20px;">  <p>WARNING</p> </div> <p>THE CAUSE OF ANY DISCOLORATION SHALL BE DETERMINED AND CORRECTED PRIOR TO NEXT FLIGHT.</p> <p>b. Input and output quill flexible couplings and surrounding area for grease leakage, damage, corrosion, and evidence of overheat as indicated by TEMP-PLATES or coupling discoloration. A change in color of one or more of the red bordered TEMP-PLATE dots from white/off-white to black indicates an overheat condition and may require replacement of both outer and inner couplings (step c).</p>		

SCHEDULED INSPECTIONS

5-12. 25 HOURS/30 DAYS — PART B (CONT)

DATA REFERENCE	INSPECTION TASK DESCRIPTION	INITIAL MECH OTHER	
Chapter 65	<p>c. Overheat TEMP-PLATES for condition and security. TEMP-PLATES must not show evidence of over temperature indication, deterioration, debonding, or excessive discoloration of the epoxy overcoating.</p> <p>d. Gearbox for proper oil level and oil for evidence of contamination.</p> <p>9. Tail rotor gearbox:</p> <p>a. Gearbox assembly for security, condition, corrosion, damage, and oil leaking.</p> <div data-bbox="776 926 992 999" style="text-align: center; border: 1px solid black; padding: 5px; width: fit-content; margin: 20px auto;"> <p>WARNING</p> </div> <p style="text-align: center;">THE CAUSE OF ANY DISCOLORATION SHALL BE DETERMINED AND CORRECTED PRIOR TO NEXT FLIGHT.</p> <p>b. Input quill flexible coupling and surrounding area for grease leakage, damage, corrosion, and evidence of overheat as indicated by TEMP-PLATES or coupling discoloration. A change in color of one or more of the red bordered TEMP-PLATE dots from white/off-white to black indicates an overheat condition and may require replacement of both outer and inner couplings (step c).</p> <p>c. Overheat TEMP-PLATES for condition and security. TEMP-PLATES must not show evidence of over temperature indication, deterioration, debonding, or excessive discoloration of the epoxy overcoating.</p> <p>d. Gearbox for proper oil level and oil for evidence of contamination.</p>		

SCHEDULED INSPECTIONS

5-12. 25 HOURS/30 DAYS — PART B (CONT)

DATA REFERENCE	INSPECTION TASK DESCRIPTION	INITIAL	
		MECH	OTHER
Chapter 64	<p>10. Tail rotor hub and blade assembly:</p> <div style="text-align: center; margin: 10px 0;">  <p>WARNING</p> </div> <p>NO CRACKS ARE PERMITTED ON ANY SURFACE OF THE TAIL ROTOR BLADES.</p> <p>a. Tail rotor blades for condition of bond lines, cracks, corrosion, leading edge erosion, damage, security, and cleanliness. Clean blades are required to maintain enhanced visibility for safety.</p> <p>b. Tail rotor hub for security, corrosion, and condition.</p> <p>c. Flapping bearings and pitch change bearings for excessive looseness and freedom of movement through full range of travel with anti-torque pedals positioned full right and then full left.</p> <p>d. Tail rotor pitch change links, crosshead, pitch horns, counterweight arms, and links for security, corrosion, and condition.</p> <p>e. Pitch link bearing and counterweight link bearing looseness shall not exceed 0.015 inch (0.381 mm) axial. Check freedom of movement through full range of travel with anti-torque pedals positioned full right and then full left.</p> <p>f. Pitch change links for binding with tail rotor blade moved to both full flapping positions. Binding is not acceptable.</p>		

SCHEDULED INSPECTIONS

5-12. 25 HOURS/30 DAYS — PART B (CONT)

DATA REFERENCE	INSPECTION TASK DESCRIPTION	INITIAL MECH OTHER	
<p>Chapter 32</p> <p>Chapter 52 and Chapter 53</p> <p>Chapter 63</p> <p>Chapter 63 and BHT-212-SI-6</p>	<p>11. Every fourth 25 hour/30 day inspection:</p> <div style="text-align: center;">  <p>CAUTION</p> </div> <p>COUNTERWEIGHT BELLCRANK RETENTION NUTS P/N MS14145L6 OR ITS EQUIVALENT MS17826-6 ARE DESIGNATED AS ONE TIME USE ONLY. IF MAINTENANCE ACTION REQUIRES THAT IT BE REMOVED, THE COUNTERWEIGHT BELLCRANK NUT IS TO BE DISCARDED AND REPLACED WITH A NEW NUT. OVERTORQUING OR INCORRECT APPLICATION OF THE NUT COULD CAUSE MECHANICAL FAILURE RESULTING IN EXCESSIVE VIBRATION OR DAMAGE TO THE TAIL ROTOR BLADES.</p> <p>a. Inspect the tail rotor counterweight bellcrank P/N 212-011-705-001 retention nuts for cracks, corrosion, and security. Reapply corrosion preventive compound (C-101) if nuts are not completely covered.</p> <p>12. Tail skid for deformation and security of attachment.</p> <p><u>CABIN ROOF</u></p> <p>1. Cabin structure and cowlings/fairings for condition.</p> <p>2. Transmission and transmission oil lines for condition, corrosion, and leaks.</p> <p>3. Rotor brake quill, disc and brake assembly (if installed):</p> <p>a. Brake quill for condition, damage, and leakage.</p> <p>b. Brake disc for condition, damage, security, warpage, and evidence of overheat.</p> <p>c. Caliper switches and wiring for condition and security of attachment.</p>		

SCHEDULED INSPECTIONS

5-12. 25 HOURS/30 DAYS — PART B (CONT)

DATA REFERENCE	INSPECTION TASK DESCRIPTION	INITIAL	
		MECH	OTHER
Chapter 29	<p>4. Hydraulic systems:</p> <p style="margin-left: 40px;">a. Hydraulic system 2 pump for leakage and security.</p> <p style="margin-left: 40px;">b. Hydraulic lines for leaks, chafing, and kinking.</p> <p style="margin-left: 40px;">c. Hydraulic system 1 and 2 reservoirs for proper fluid levels, damage, corrosion, and security.</p>		
Chapter 62	<p>5. Main rotor blades:</p> <p style="margin-left: 40px;">a. Main rotor blades upper and lower surfaces for condition of bond lines, doublers, and leading edge for erosion. Inspect blade surfaces for corrosion, cracks, damage, and voids.</p> <p style="margin-left: 40px;">b. Every fourth 25 hour/30 day inspection, wash main rotor blades with mild soap and water. Rinse and dry thoroughly.</p>		
Chapter 62	<p>6. Main rotor hub:</p> <p style="margin-left: 40px;">— Detailed Visual Inspection</p> <p style="margin-left: 40px;">a. Main rotor hub assembly (grips, drag braces, trunnion pillow blocks, static stops, and mast nut) for condition and security.</p> <p style="margin-left: 40px;">b. Hub assembly for proper oil level or grease lubrication.</p> <p style="margin-left: 40px;">c. Main rotor yoke for evidence of cracks at pillow block bushing bores. Proper sealing of pillow blocks, yoke, and attaching through bolts, washers, nuts, and bushings.</p>		
Chapter 62	<p>7. Main rotor controls:</p> <p style="text-align: center;">NOTE</p> <p style="margin-left: 40px;">The presence of black oxide powder will require investigation to determine the cause.</p>		

SCHEDULED INSPECTIONS

5-12. 25 HOURS/30 DAYS — PART B (CONT)

DATA REFERENCE	INSPECTION TASK DESCRIPTION	INITIAL	
		MECH	OTHER
	<p>a. Swashplate and support assembly and collective lever for security and mechanical and corrosion damage. Pay special attention to gimbal ring bearings, trunnion bearings, and attaching hardware for excessive looseness and security. Gimbal ring bearing and attaching bolt axial or radial looseness shall not exceed 0.005 inch (0.127 mm) and no binding is allowed.</p> <p>— Detailed Visual Inspection</p> <p>b. Every fourth 25 hour/30 day inspection, disconnect flight control tubes from swashplate and collective lever assembly. Inspect six bearings 204-011-451-001 for 0.020 inch (0.508 mm) maximum axial play. Rotate bearings 180° and purge lubricate.</p> <p>c. Scissors and sleeve assembly for security and condition. Collective lever for condition and evidence of corrosion.</p> <p>d. Every fourth 25 hour/30 day inspection, replace bearings MS20201KP8A or MS27641-8 in scissors levers 204-011-406.</p> <p>e. Pitch links, damper tubes, and connecting links for condition and security. Bearings for looseness.</p> <p>f. Stabilizer bar dampers for condition, security, and proper fluid level.</p> <p>g. Every fourth 25 hour/30 day inspection, replace bearings AN201KP6A or MS27641-6 in mixing levers 204-011-301.</p> <p>h. Inspect stabilizer bar assembly for condition and security. Pay particular attention to tubes P/N 204-011-328-001 and -011 for cracks. Closely inspect area covering 360° 1.5 inches (38.1 mm) outboard from vertical bolt AN174-23A.</p>		

SCHEDULED INSPECTIONS

5-12. 25 HOURS/30 DAYS — PART B (CONT)

DATA REFERENCE	INSPECTION TASK DESCRIPTION	INITIAL	
		MECH	OTHER
Chapter 63	<p>8. Main rotor mast:</p> <p>a. Inspect mast assembly for security, corrosion, and mechanical damage. Pay particular attention to area contacted by main rotor static stops and damper assembly/adaptor set splines.</p> <p>b. Inspect for evidence of oil leaks at mast bearing cap.</p> <p>c. Mast nut for security.</p>		
Chapter 63	<p>9. Engine-to-transmission (main) driveshaft:</p> <p>a. Main driveshaft for corrosion, condition, and security.</p> <div style="text-align: center; margin: 10px 0;"> <div style="border: 1px solid black; padding: 2px; display: inline-block;">WARNING</div> </div> <p>THE CAUSE OF ANY DISCOLORATION SHALL BE DETERMINED AND CORRECTED PRIOR TO NEXT FLIGHT.</p> <p>b. Main driveshaft forward and aft couplings, boots, seals and surrounding area for grease leakage, damage, corrosion, and evidence of overheat as indicated by TEMP-PLATES or coupling discoloration. A change in color of any yellow bordered TEMP-PLATE, from white/off-white to black, will indicate a possible overheat condition and/or component degradation (step c). If one or more of the red bordered TEMP-PLATE dots change from white/off-white to black, an overheat condition is present and may require replacement of both outer and inner couplings.</p> <p>c. Overheat TEMP-PLATES for condition and security. TEMP-PLATES must not show evidence of overtemperature indication, deterioration, debonding, or excessive discoloration of the epoxy overcoating.</p>		



SCHEDULED INSPECTIONS

5-13. 300 HOURS/12 MONTHS INSPECTION — PART B

DATA REFERENCE	INSPECTION TASK DESCRIPTION	INITIAL	
		MECH	OTHER
	<p>DATE: _____ W.O. _____</p> <p>FACILITY: _____</p> <p>HELICOPTER S/N: _____</p> <p>REGISTRY NO.: _____</p> <p>TOTAL TIME: _____</p> <p>SIGNATURE: _____</p> <p style="text-align: center;">NOTE</p> <p>For helicopters on the Part B inspection program, accomplish the following checks each 300 hours of flight operation or 12 calendar months whichever occurs first.</p> <p><u>GENERAL</u></p> <p>Each listed inspection item or maintenance function is to be performed in accordance with the chapter specified.</p> <p><u>PRELIMINARY REQUIREMENTS</u></p> <ol style="list-style-type: none"> 1. All work accomplished during inspection shall be recorded in helicopter maintenance records. 2. Remove all panels, fairings, and cowlings required to satisfactorily carry out the inspection. 3. Deleted. <p><u>AFTER COMPLETION OF INSPECTION</u></p> <ol style="list-style-type: none"> 1. Reinstall all panels, fairings, and cowlings removed during inspection. 2. Carry out a ground run and leak check prior to releasing the helicopter back to service. 		



SCHEDULED INSPECTIONS

5-13. 300 HOURS/12 MONTHS INSPECTION — PART B (CONT)

DATA REFERENCE	INSPECTION TASK DESCRIPTION	INITIAL	
		MECH	OTHER
Chapter 53	<p><u>FUSELAGE — CABIN</u></p> <p>1. Forward fuselage:</p> <ul style="list-style-type: none"> a. Cabin exterior structure for corrosion and damage. b. Cabin interior structure for corrosion and damage. c. Ensure all drain holes are open. d. All compartments for evidence of water entrapment and corrosion. <p>2. Underside of fuselage:</p> <ul style="list-style-type: none"> a. Fuselage structure for damage, corrosion, and working rivets. b. Exterior finish for condition and cleanliness. c. Evidence of excessive fluid leakage. d. Structure around landing gear for condition. e. Forward crosstube support structure for working fasteners, cracks, corrosion, and excessive wear. f. Aft crosstube support structure for working fasteners, cracks, corrosion, and excessive wear. 		
Chapter 52	<p>3. Doors and windows:</p> <ul style="list-style-type: none"> a. Crew and passenger doors structure for corrosion, damage, distortion, and positive locking mechanisms. Seals for adherence, tears, separations, and deterioration. b. Crew doors emergency jettison mechanism for condition and security. Perform operational check. 		



SCHEDULED INSPECTIONS

5-13. 300 HOURS/12 MONTHS INSPECTION — PART B (CONT)

DATA REFERENCE	INSPECTION TASK DESCRIPTION	INITIAL MECH OTHER	
Chapter 67	<p style="text-align: center;">NOTE</p> <p>The following inspection (step c and step d) is for helicopters equipped with escape panels which may be identified by a rotating handle installed below the passenger door windows. The handle is labeled EMERGENCY RELEASE PULL COVER TURN LEFT AND PUSH.</p> <p>c. Inspect passenger door emergency egress panel pins and mechanisms for wear, corrosion, operation, and security.</p> <p>d. Perform operational check of passenger door escape panels.</p> <p>e. Passenger door window retainers and fillers (if applicable) for damage.</p> <p>f. Nose, electrical, and equipment compartment access doors for corrosion, damage, distortion, and positive locking mechanisms.</p> <p>g. Inspect heated windshield, if installed, for condition and proper operation.</p> <p>4. Collective flight control actuator.</p> <p>a. Universal bearings for looseness.</p> <p>b. Input lever bearings and bolts for wear and looseness.</p> <p>c. Fasteners attaching cylinder lower supports to structure for looseness.</p> <p>d. Cylinder lower bearings for looseness.</p> <p>e. Actuator assembly for damage and leakage.</p> <p>f. Cylinder extension tube for condition and security.</p> <p>g. Actuator linkage, balance spring, and bracket for wear and security.</p>		



SCHEDULED INSPECTIONS

5-13. 300 HOURS/12 MONTHS INSPECTION — PART B (CONT)

DATA REFERENCE	INSPECTION TASK DESCRIPTION	INITIAL	
		MECH	OTHER
BHT-ALL-SPM	<p>h. Clean exposed area of actuator piston with hydraulic fluid and a clean lint-free cloth.</p> <p>i. Check hydraulic cylinder piston rod for evidence of excessive wear and scoring. Wear of the piston rod indicates cylinder assembly is incorrectly aligned to lower support and requires adjustment.</p> <p>j. Remove bolts attaching actuator to lower supports. Check cylinder alignment to lower support. Rod end bearing side loads are not permitted. Install bolts.</p> <p>k. Torque check nuts attaching actuator cylinder to upper supports.</p> <p>l. Upper cylinder housing mounting bracket cavity for corrosion. Cavity drain hole for obstruction. Reapply corrosion preventive compound (C-104) as required. Dust boot for condition.</p>		
Chapter 67	<p>5. Collective control tubes:</p> <p>a. Control tubes between collective jackshaft and collective control actuator pilot valve input lever for corrosion, wear, and damage.</p> <p>b. Control tube bellcrank, supports, and attaching hardware for corrosion, wear, and damage.</p>		
Chapter 67	<p>6. Cyclic flight control actuators.</p> <p>a. Universal bearings for looseness.</p> <p>b. Input lever bearings and bolts for wear and looseness.</p> <p>c. Fasteners attaching cylinder lower supports to structure for looseness.</p> <p>d. Cylinder lower bearings for looseness.</p> <p>e. Actuator assembly for damage and leakage.</p> <p>f. Cylinder extension tube for condition and security.</p>		



SCHEDULED INSPECTIONS

5-13. 300 HOURS/12 MONTHS INSPECTION — PART B (CONT)

DATA REFERENCE	INSPECTION TASK DESCRIPTION	INITIAL	
		MECH	OTHER
BHT-ALL-SPM	<p>g. Actuator linkage for wear and security.</p> <p>h. Clean exposed area of actuator piston with hydraulic fluid and a clean lint-free cloth.</p> <p>i. Check hydraulic cylinder piston rod for evidence of excessive wear and scoring. Wear of the piston rod indicates cylinder assembly is incorrectly aligned to lower support and requires adjustment.</p> <p>j. Remove bolts attaching actuator to lower supports. Check cylinder alignment to lower support. Rod end bearing side loads are not permitted. Install bolts.</p> <p>k. Torque check nuts attaching actuator cylinder to upper supports.</p> <p>l. Upper cylinder housing mounting bracket cavity for corrosion. Cavity drain hole for obstruction. Reapply corrosion preventive compound (C-104) as required. Dust boot for condition.</p>		
Chapter 67	<p>7. Cyclic control tubes:</p> <p>a. Control tubes between cyclic jackshaft and cyclic control actuator pilot valve input lever for corrosion, wear, and damage.</p> <p>b. Control tube bellcranks, mixing levers, supports, and attaching hardware for corrosion, wear, and damage.</p>		
Chapter 63	<p>8. Transmission:</p> <p>a. All transmission chip detectors for debris.</p> <p>b. Clean all transmission chip detectors.</p> <p>c. Test all transmission chip detector electrical circuits.</p> <p>d. Refer to Special Inspection paragraph 5-25, paragraph 5-27 and paragraph 5-34 (as applicable) for transmission oil change and internal oil filter or full flow debris monitor inspection requirements.</p> <p>e. Deleted.</p>		



SCHEDULED INSPECTIONS

5-13. 300 HOURS/12 MONTHS INSPECTION — PART B (CONT)

DATA REFERENCE	INSPECTION TASK DESCRIPTION	INITIAL	
		MECH	OTHER
BHT-212-CR&O	<p>f. Mounts for damage and security.</p> <p>g. Lift link and attachments for corrosion, damage, and security. Bearings for looseness.</p> <p>h. Torque check — top case to ring gear case nuts, ring gear case to main case nuts and main case to support case nuts 230 to 250 inch-pounds (25.99 to 28.25 Nm). Retorque as required.</p>		
Chapter 71	<p><u>POWER PLANT</u></p> <p style="text-align: center;">NOTE</p> <p>If applicable, refer to BHT-212-SI-96 for installation of adjustable seals or refer to Chapter 71 for seal adjustment.</p>		
ASB 212-10-137	<p>1. Inspect the left-hand and right-hand engine air inlet cowlings for gaps between the lower surface of the cowling firewall and the mating horizontal engine firewall.</p>		
Chapter 71	<p><u>LEFT POWER SECTION</u></p> <p style="text-align: center;">NOTE</p> <p>Refer to Pratt & Whitney Canada PT6T-3/-3B Maintenance Manual for engine inspection requirements.</p> <p>1. Chip detectors for debris.</p> <p>2. Clean chip detector.</p> <p>3. Test chip detector electrical circuits.</p> <p><u>RIGHT POWER SECTION</u></p> <p style="text-align: center;">NOTE</p> <p>Refer to Pratt & Whitney Canada PT6T-3/-3B Maintenance Manual for engine inspection requirements.</p>		



SCHEDULED INSPECTIONS

5-13. 300 HOURS/12 MONTHS INSPECTION — PART B (CONT)

DATA REFERENCE	INSPECTION TASK DESCRIPTION	INITIAL	
		MECH	OTHER
Chapter 71	<ol style="list-style-type: none"> 1. Chip detectors for debris. 2. Clean chip detector. 3. Test chip detector electrical circuits. <p><u>ENGINE ELECTRICAL CONNECTIONS</u></p> <ol style="list-style-type: none"> 1. Left power section ignition leads for corrosion, chafing, and security. 2. Right power section ignition leads for corrosion, chafing, and security. 		
Chapter 71	<p><u>COMBINING (REDUCTION) GEARBOX</u></p> <p style="text-align: center;">NOTE</p> <p>Refer to Pratt & Whitney Canada PT6T-3/-3B Maintenance Manual for engine inspection requirements.</p> <ol style="list-style-type: none"> 1. Chip detectors for debris. 2. Clean chip detector. 3. Test chip detector electrical circuits 		
Chapter 71	<p><u>STARTER GENERATOR</u></p> <ol style="list-style-type: none"> 1. Left power section starter generator brushes for allowable wear. 2. Right power section starter generator brushes for allowable wear. 3. Left power section starter generator cooling ducts for obstruction, kinking, and security. 4. Right power section starter generator cooling ducts for obstruction, kinking, and security. 		



SCHEDULED INSPECTIONS

5-13. 300 HOURS/12 MONTHS INSPECTION — PART B (CONT)

DATA REFERENCE	INSPECTION TASK DESCRIPTION	INITIAL	
		MECH	OTHER
Chapter 76	<p><u>ENGINE FUEL AND POWER CONTROLS</u></p> <ol style="list-style-type: none"> 1. Engine control linkages for looseness, lost motion, chafing, damage, and security of attachment. 2. Bellcranks, mounts, and jackshafts. 3. Check controls for smooth movement through full travel ranges. 		
BHT-212-FM-1	<ol style="list-style-type: none"> 4. Check engine fuel control. 		
Chapter 96	<p><u>POWER DIODES</u></p> <p>Perform functional check of power diodes.</p>		
Chapter 32	<p><u>LANDING GEAR SYSTEM</u></p> <ol style="list-style-type: none"> 1. Landing gear skid shoes for excessive wear, cracks, damage, corrosion, and security of attachment. 2. Torque check crosstube to skid tube saddle bolts. 3. Torque check forward and aft crosstube support fittings U-bolts 80 to 100 inch-pounds (9.0 to 11.3 Nm). 4. Torque check ground handling wheel attachment eyebolts on skid tubes 40 to 58 foot-pounds (54 to 79 Nm). Eyebolts that rotate prior to reaching 40 foot-pounds (54 Nm) shall be removed and inspected for evidence of bending. No bending is permitted. 		
Chapter 26	<p><u>FIRE DETECTION SYSTEM</u></p> <p>— General Visual Inspection</p> <ol style="list-style-type: none"> 1. Engine fire detection elements for condition and security. 		
Chapter 53	<p><u>TAILBOOM</u></p> <ol style="list-style-type: none"> 1. Tailboom structure: <ol style="list-style-type: none"> a. Tailboom exterior structure for corrosion and damage. 		



SCHEDULED INSPECTIONS

5-13. 300 HOURS/12 MONTHS INSPECTION — PART B (CONT)

DATA REFERENCE	INSPECTION TASK DESCRIPTION	INITIAL	
		MECH	OTHER
ASB 212-90-63	<p>b. Tailboom interior structure for corrosion and damage.</p> <p>c. Inspect tailboom joints, splices, longerons, attach fittings, and attaching hardware for corrosion, damage, and cracks.</p> <p>d. Remove plug button at BS 99.00.</p> <p style="text-align: center;">NOTE</p> <p>Paint fissures are common in the splice area, cracks will be evident by black powder emanating from cracked area, and corrosion will leave evidence of white powder.</p> <p>e. Using a borescope or suitable means, inspect inside of longeron paying particular attention to cracking and/or corrosion in area of splice.</p> <p>f. Report any cracks to Product Support Engineering.</p> <p>g. Install plug button with sealant (C-308).</p> <p>h. Ensure all drain holes are open.</p> <p>i. Vertical fin spar caps forward side and web from upper tailboom skin to approximately 4 inches (101.6 mm) below upper tailboom skin as follows: remove aft tailboom access door. Face aft and use bright light and small mirror to inspect area for cracks, especially near rivet holes.</p>		
BHT-ALL-SPM	<p style="text-align: center;">NOTE</p> <p>If necessary, clean area with cloth dampened with MEK (C-309) or equivalent. Ventilate area to prevent breathing fumes.</p>		
Chapter 67	<p>2. Anti-torque controls:</p> <p>a. Tail rotor control tubes between tail rotor pedals and tail rotor gearbox for corrosion, wear, and damage.</p> <p>b. Control tube bellcrank, supports, and attaching hardware for corrosion, security, wear, and damage.</p>		



SCHEDULED INSPECTIONS

5-13. 300 HOURS/12 MONTHS INSPECTION — PART B (CONT)

DATA REFERENCE	INSPECTION TASK DESCRIPTION	INITIAL	
		MECH	OTHER
Chapter 67	<p>c. Tail rotor hydraulic actuator for leaks and security of attachment, damage, corrosion, and bearings and linkages for looseness.</p> <p>3. Elevator:</p> <p>— Detailed Visual Inspection</p> <p>a. Check synchronized elevator push-pull tubes for chafing, corrosion, wear, and damage.</p> <p>b. Check elevator and horn assembly for security, cracks, wear, damage, and corrosion.</p> <p>c. Check left and right elevator assemblies for excessive axial and radial play using a dial indicator mounted on the tailboom, with stylus touching inboard edge of elevator near attachment bolt for axial measurement, and touching upper surface near attachment bolt for radial measurement. Applying light force to move elevator in required direction, check that radial movement does not exceed 0.010 inch (0.254 mm), and that axial movement is within 0.005 to 0.030 inch (0.127 to 0.762 mm). Adjust shims as required.</p> <p>d. Elevator rigging for proper setting and travel.</p>		
Chapter 52	4. Baggage compartment door for corrosion, damage, distortion, and positive locking mechanism.		
Chapter 26	5. Baggage compartment smoke detector for condition and security.		
Chapter 96	6. Inspect wire bundles and clamping for chafing, condition, and security.		
Chapter 65	<p>7. Tail rotor driveshaft:</p> <p>a. Hanger assemblies for cracks at mounting ears, corrosion, and security of attachment.</p> <p>b. Hanger supports for condition and security of attachment.</p>		



SCHEDULED INSPECTIONS

5-13. 300 HOURS/12 MONTHS INSPECTION — PART B (CONT)

DATA REFERENCE	INSPECTION TASK DESCRIPTION	INITIAL	
		MECH	OTHER
	<p>c. Driveshaft sections and attaching hardware for condition and security.</p> <p>d. Coupling clamps for cracks in or near bolt lugs. Clamps for proper position.</p>		
Chapter 65	<p>8. Intermediate gearbox:</p> <p>a. Chip detector for debris.</p> <p>b. Clean chip detector.</p> <p>c. Functionally test chip detector electrical circuit.</p>		
Chapter 12	d. Service gearbox as required.		
Chapter 65	<p>9. Tail rotor gearbox:</p> <p>a. Chip detector for debris.</p> <p>b. Clean chip detector.</p> <p>c. Functionally test chip detector electrical circuit.</p>		
Chapter 12	d. Service gearbox as required.		
Chapter 64	<p>10. Tail rotor hub and blade assembly:</p> <p>a. Torque check nuts on tail rotor blade retention bolts.</p> <p>b. Torque check tail rotor hub retaining nut.</p>		
Chapter 18	c. Dynamically balance tail rotor.		
Chapter 62	<p><u>MAIN ROTOR BLADE INSPECTION SYSTEM (BIS) (IF INSTALLED)</u></p> <p>— Inspect</p>		
BHT-212-CR&O and Chapter 96	<p>1. Test detector unit.</p> <p>2. Perform continuity check on blade conductor circuits.</p>		



SCHEDULED INSPECTIONS

5-13. 300 HOURS/12 MONTHS INSPECTION — PART B (CONT)

DATA REFERENCE	INSPECTION TASK DESCRIPTION	INITIAL	
		MECH	OTHER
<p>Chapter 52 and Chapter 53</p>	<p>3. Remove BIS battery.</p> <p>4. Perform battery condition check on replacement battery. Install replacement battery.</p> <p><u>CABIN ROOF</u></p> <p>1. Cabin roof structure:</p> <p style="padding-left: 40px;">a. Cabin roof structure, cowlings and fairings for damage, delamination, and general condition.</p> <p style="padding-left: 40px;">b. Cabin roof and cowling/fairing mounted antennas for condition and security.</p>		



SCHEDULED INSPECTIONS

5-14. 600 HOURS/12 MONTHS — PART B

DATA REFERENCE	INSPECTION TASK DESCRIPTION	INITIAL MECH OTHER	
	<p>DATE: _____ W.O. _____</p> <p>FACILITY: _____</p> <p>HELICOPTER S/N: _____</p> <p>REGISTRY NO.: _____</p> <p>TOTAL TIME: _____</p> <p>SIGNATURE: _____</p> <p style="text-align: center;">NOTE</p> <p style="text-align: center;">For helicopters on the Part B inspection program, accomplish the following checks each 600 hours flight time or 12 calendar months, whichever occurs first.</p> <p><u>GENERAL</u></p> <p>Each listed inspection item or maintenance function is to be performed in accordance with the 212 Maintenance Manual chapter specified.</p> <p><u>PRELIMINARY REQUIREMENTS</u></p> <ol style="list-style-type: none"> 1. All work accomplished during inspection shall be recorded in helicopter maintenance records. 2. Remove all fuselage and tailboom access panels, removable floor panels, fairings, and cowlings. 3. Deleted. 4. Ensure all applicable Special Inspections, Alert Service Bulletins, and Airworthiness Directives have been accomplished. 		

SCHEDULED INSPECTIONS

5-14. 600 HOURS/12 MONTHS — PART B (CONT)

DATA REFERENCE	INSPECTION TASK DESCRIPTION	INITIAL	
		MECH	OTHER
	<p style="text-align: center;"><u>AFTER COMPLETION OF INSPECTION</u></p> <p>1. Reinstall all panels, fairings, and cowlings removed during inspection.</p> <p>2. Carry out a ground run and leak check prior to releasing the helicopter back to service.</p> <p style="text-align: center;"><u>FUSELAGE</u></p>		
Chapter 25	<p>1. Emergency and safety equipment:</p> <p style="padding-left: 40px;">a. Emergency and safety equipment for inspection due dates.</p> <p style="padding-left: 40px;">b. Contents of first aid kit for missing or over age items.</p>		
Chapter 26	<p>2. Perform weight check of cockpit and cabin portable fire extinguishers.</p>		
Chapter 52	<p>3. Perform operational check of crew doors emergency release mechanisms.</p>		
Chapter 21 and Chapter 96	<p>4. Bleed air heating and ventilation/defog system components:</p> <p style="padding-left: 40px;">a. Perform functional check of bleed air heating system and components.</p> <p style="padding-left: 40px;">b. Perform functional check of defog blower.</p>		
Chapter 95	<p>5. Instruments: (required at 12 months calendar time only)</p> <p style="padding-left: 40px;">a. Calibrate pilot and copilot compass systems and standby magnetic compass.</p> <p style="padding-left: 40px;">b. Drain pitot-static system of any accumulated moisture.</p> <p style="padding-left: 40px;">c. Test pitot-static system for leaks.</p>		
Chapter 96	<p>6. Perform functional check of battery temperature sensor caution light system.</p>		

SCHEDULED INSPECTIONS

5-14. 600 HOURS/12 MONTHS — PART B (CONT)

DATA REFERENCE	INSPECTION TASK DESCRIPTION	INITIAL	
		MECH	OTHER
Chapter 67	<p>7. Collective flight controls:</p> <p>a. Friction shoes and liners for condition.</p> <p>b. Flight control systems bellcrank and control tubes for damage, chafing, corrosion, and security of attachment.</p> <p>c. Functionally check collective lever friction adjuster for proper friction and operation.</p> <p>d. Functionally check collective minimum friction for proper friction and operation</p> <p>e. Functionally check collective flight controls for smooth movement throughout their full travel ranges.</p>		
Chapter 67	<p>8. Cyclic flight controls.</p> <p>a. Flight control systems bellcrank and control tubes for damage, chafing, corrosion, and security of attachment.</p> <p>b. Functionally check cyclic stick friction adjuster for proper friction and operation.</p> <p>c. Functionally check cyclic flight controls for smooth movement throughout their full travel ranges.</p>		
Chapter 67	<p>9. Anti-torque flight controls:</p> <p>a. Flight control systems bellcrank and control tubes for damage, chafing, corrosion, and security of attachment.</p> <p>b. Functionally check anti-torque friction adjuster for proper friction and operation.</p> <p>c. Functionally check anti-torque flight controls for smooth movement throughout their full travel ranges.</p>		



SCHEDULED INSPECTIONS

5-14. 600 HOURS/12 MONTHS — PART B (CONT)

DATA REFERENCE	INSPECTION TASK DESCRIPTION	INITIAL	
		MECH	OTHER
Chapter 62	<p>10. Swashplate and support assembly, and scissors and sleeve assembly:</p> <p style="margin-left: 40px;">a. Disconnect bottom of each drive link from swashplate trunnion and each mixing lever control tube from scissors.</p> <p style="margin-left: 40px;">b. Check swashplate duplex bearing and collective sleeve hub bearing set for roughness and ease of rotation.</p> <p style="margin-left: 40px;">c. Purge lubricate bearings.</p> <p style="margin-left: 40px;">d. Reconnect drive links and tubes.</p>		
Chapter 76 Pratt & Whitney Canada PT6T-3/-3B Maintenance Manual	<p>11. Engine: Perform maximum N_G topping check.</p>		
Chapter 76	<p>12. Engine controls:</p> <p style="margin-left: 40px;">a. Deleted.</p> <p style="margin-left: 40px;">b. Functionally check collective lever throttle friction adjusters for proper friction and operation.</p> <p style="margin-left: 40px;">c. Deleted.</p> <p>13. Inspect all exposed fuel lines and attachments for leakage, damage, and security.</p>		
Chapter 29	<p>14. Hydraulic system:</p> <p style="text-align: center;">NOTE</p> <p>Hydraulic filter elements 205-076-034-003 are non-cleanable. It is recommended they be replaced every 600 hours or 12 months. Filter elements 205-076-034-007 are cleanable. The -003 and -007 elements are interchangeable. Intermixing of different element types is not permitted.</p>		

SCHEDULED INSPECTIONS

5-14. 600 HOURS/12 MONTHS — PART B (CONT)

DATA REFERENCE	INSPECTION TASK DESCRIPTION	INITIAL	
		MECH	OTHER
Chapter 63	<p>a. Remove and inspect hydraulic filter elements.</p> <p>b. Discard or clean filter elements as applicable.</p> <p>c. Install hydraulic filter elements.</p> <p>d. Install 0 to 500 PSIG (0 to 3447 kPa) gauge in quick disconnect at rotor brake caliper. Slowly pull rotor brake handle through travel. Cylinder should generate 240 to 260 PSI (1655 to 1793 kPa) at any handle velocity and shall maintain 150 SPI (1034 kPa) minimum in over center position for 3 minutes. Adjust as necessary.</p>		
Chapter 53	<p>e. Inspect rotor brake linings for wear (minimum thickness 0.150 inch (3.81 mm)).</p> <p>15. Fuselage cabin structure:</p> <p>a. Fuselage structure for corrosion and damage to finish and sealant. Pay particular attention to edges of joints and seams and around fastener heads.</p> <p>b. Ensure all drain holes are open.</p> <p>c. Engine compartment floor and service deck, FS 155.06 to 241.22 for damage, delamination, and corrosion.</p> <p>d. Fuselage bonded panels for damage and delamination.</p> <p style="text-align: center;">NOTE</p> <p>To adequately inspect the following, it will be necessary to remove the auxiliary fuel tanks, if installed.</p> <p>e. Pylon wall for damage, working fasteners, cracks, delamination, and corrosion.</p>		
Chapter 96	<p>16. Electrical system:</p> <p>a. Check inverters for security of mounting and connections.</p>		



SCHEDULED INSPECTIONS

5-14. 600 HOURS/12 MONTHS — PART B (CONT)

DATA REFERENCE	INSPECTION TASK DESCRIPTION	INITIAL	
		MECH	OTHER
Chapter 4, Chapter 26, and Chapter 96	<p>b. Check generator control units for damage and security of mounting and terminals.</p> <p>c. Inspect all exposed wire bundles, bundle supports and connectors for damage, corrosion, and security. Pay particular attention to engine deck connectors and harnesses.</p> <p>d. Inspect relays and main bus area for security of mounting and connections.</p> <p>e. Inspect bus insulation for damage and condition.</p> <p>17. Deleted.</p> <p>18. Fire extinguishing system:</p> <p>a. Functionally check voltage of engine fire extinguishing circuits.</p> <p>b. Replace engine fire extinguisher container firing cartridges in accordance with specified service life.</p> <p>c. Visually inspect the loop clamp installed on modified discharge tubes 212-060-921-001FM and -002FM for condition and security until Part III of referenced ASB is accomplished.</p> <p>19. Remove four access doors, located just forward of the aft crosstube, from the underside of the fuselage. Inspect fuel lines for evidence of leakage, damage, and security.</p> <p style="text-align: center;">NOTE</p> <p style="text-align: center;">The following step is to be performed every 12 months.</p> <p>20. Inspect all fuel system, oil system, and hydraulic system filler caps for proper functioning and sealing. Make sure the sealing O-rings within the filler caps are in good condition. Repair or replace the filler caps or replace sealing O-rings as required.</p> <p><u>TAILBOOM</u></p> <p>1. Tailboom structure for corrosion and damage to finish and sealant. Pay particular attention to edges of joints and seams and around fastener heads.</p>		
ASB 212-12-146			
Chapter 28			
Chapter 53			

SCHEDULED INSPECTIONS

5-14. 600 HOURS/12 MONTHS — PART B (CONT)

DATA REFERENCE	INSPECTION TASK DESCRIPTION	INITIAL	
		MECH	OTHER
Chapter 26	2. Functionally check baggage compartment smoke detector.		
Chapter 67	3. Synchronized elevator: <ul style="list-style-type: none"> a. Remove left and right elevators. b. Clean elevator spars and inspect for corrosion. c. Clean internal bore of elevator horn and inspect for corrosion. d. With elevator control removed, attach a spring scale to hole in arm of horn where control tube is normally installed. Pull scale at right angle to arm, verify friction is 26 to 32 pounds (115.65 to 142.34 N). If friction is not within limits, adjust shim thickness. e. Install left and right elevators. 		



SCHEDULED INSPECTIONS

5-15. 5000 HOURS/5 YEARS INSPECTION — PART B

DATA REFERENCE	INSPECTION TASK DESCRIPTION	INITIAL MECH OTHER	
Chapter 96	<p>DATE: _____ W.O. _____</p> <p>FACILITY: _____</p> <p>HELICOPTER S/N: _____</p> <p>REGISTRY NO.: _____</p> <p>TOTAL TIME: _____</p> <p>SIGNATURE: _____</p> <p style="text-align: center;">NOTE</p> <p>For helicopters on the Part B inspection program, accomplish the following checks each 5000 hours flight time or 60 months, whichever occurs first.</p> <p>This inspection is meant to be a full visual inspection of the airframe primarily for environmental damage and corrosion.</p> <p><u>GENERAL</u></p> <p>Each listed inspection item or maintenance function is to be performed in accordance with the BHT-212-MM chapter specified or the BHT-212-CR&O.</p> <p><u>PRELIMINARY REQUIREMENTS</u></p> <ol style="list-style-type: none"> 1. All work accomplished during this inspection shall be recorded in the helicopter maintenance records. 2. Remove all panels, interior coverings, fairings, and cowlings required to satisfactorily carry out the inspection. 3. Remove the following items: <ol style="list-style-type: none"> a. Main battery. 		



SCHEDULED INSPECTIONS

5-15. 5000 HOURS/5 YEARS INSPECTION — PART B (CONT)

DATA REFERENCE	INSPECTION TASK DESCRIPTION	INITIAL	
		MECH	OTHER
Chapter 97	b. Electrical and avionics equipment from the nose area, as required, to allow a full visual inspection of the nose area to be performed.		
Chapter 62	c. Main rotor transmission.		
Chapter 65	d. Intermediate gearbox.		
Chapter 64	e. Tail rotor gearbox.		
Chapter 53	f. Tailboom (to allow a full inspection of the aft fuselage bulkhead and forward tailboom bulkhead).		
Chapter 32	g. Landing gear assembly (to allow a complete inspection of the landing gear attachment points and support structure).		
	<p>4. In addition to the 5000 Hour/5 Year Inspection — Part B items, do the following:</p> <p>a. Complete 25 Hour/30 Day Inspection — Part B.</p> <p>b. Complete 300 Hour/12 Month Inspection — Part B.</p> <p>c. Complete 600 Hour/12 Month Inspection — Part B.</p> <p><u>AFTER COMPLETION OF INSPECTION</u></p> <p>1. Install the following items:</p>		
Chapter 96	a. Main battery.		
Chapter 97	b. Electrical and avionics equipment on the nose area.		
Chapter 62	c. Main rotor transmission.		
Chapter 65	d. Intermediate gearbox.		
Chapter 64	e. Tail rotor gearbox.		
Chapter 53	f. Tailboom.		
Chapter 32	g. Landing gear assembly.		



SCHEDULED INSPECTIONS

5-15. 5000 HOURS/5 YEARS INSPECTION — PART B (CONT)

DATA REFERENCE	INSPECTION TASK DESCRIPTION	INITIAL	
		MECH	OTHER
Chapter 53	<p>2. Install all panels, interior coverings, fairings, and cowlings removed during inspection.</p> <p>3. Do a ground run and leak check before you return the helicopter to service.</p> <p><u>FORWARD FUSELAGE</u></p> <p>1. Nose panels in area of pitot tube attachment, areas inside and outside for disbonding and cracking.</p> <p>2. Pitot tubes attachment for looseness.</p> <p>3. Nose shelves for damage, corrosion, and disbonding.</p> <p>4. Nose shelf attachment locations for damage, corrosion, and cracking.</p> <p>5. Right and left BL 14.00 main beams, forward of STA 23.00 for damage, corrosion, and cracking.</p> <p>6. Instrument panel attachment structure for damage, corrosion, and cracking, primarily in the door frame attachment area.</p> <p>7. Instrument panel glareshield for chafing and cracking.</p> <p>8. Crew door hinge attachment structure for damage and cracks.</p> <p>9. Outboard cabin post (1, Figure 5-3), cabin roof longeron (2), and windshield frame (5) upper corner area for damage and cracks.</p> <p>10. Striker plates (3 and 4) attachment areas for damage and cracks.</p> <p>11. Striker plates (3 and 4) for excessive wear, damage, and corrosion.</p> <p>12. Cabin floor area under crew doors for chafing and damage.</p> <p>13. Crew door hinges for wear, damage, corrosion, and security of attachment.</p>		



SCHEDULED INSPECTIONS

5-15. 5000 HOURS/5 YEARS INSPECTION — PART B (CONT)

DATA REFERENCE	INSPECTION TASK DESCRIPTION	INITIAL	
		MECH	OTHER
	<p>14. Crew doors for proper fit and operation.</p> <p>15. Crew seat rails for excessive wear and damage.</p> <p>16. Center and outboard bulkhead, below WL 22.00 at FS 23.00, for cracks, deformation, and corrosion along structure joints.</p> <p>17. Collective and cyclic control jackshafts support intercostals for cracks and corrosion.</p> <p>18. Cyclic support for corrosion and cracks.</p> <p>19. Collective, cyclic, and anti-torque control system bellcranks, levers, and support brackets for corrosion, cracks, and indication of wear at attaching points.</p> <p>20. Crew seat support beams, at BL 14.00 and 30.00 between FS 23.00 and 74.30, for cracks and corrosion.</p> <p>21. Forward crosstube attachment points and support structure at FS 63.33 and 74.30 for damage, corrosion, and cracks.</p> <p>22. Aft crosstube attachment points and support structure at FS 155.06 and 166.00 for damage, corrosion, and cracks.</p> <p>23. Crew and passenger cabin floor, FS 23.00 to 155.06, for corrosion and damage. Floor bonded panels for voids. Seat fasteners and cargo tie-down rings for condition. Area around pilot and copilot ICS foot switches for cracks.</p> <p style="text-align: center;">NOTE</p> <p style="text-align: center;">In the following step, removal of the fuel cells is not required unless there is evidence of fuel leakage or damage to the fuel cells or structure is suspected.</p> <p>24. All structure under floor panels and in forward fuel cell cavities including caps, angles, transverse bulkheads and bonded panels between FS 74.30 and 155.06 for damage, corrosion, cracks, and voids.</p>		



SCHEDULED INSPECTIONS

5-15. 5000 HOURS/5 YEARS INSPECTION — PART B (CONT)

DATA REFERENCE	INSPECTION TASK DESCRIPTION	INITIAL MECH OTHER	
	<p style="text-align: center;">NOTE</p> <p>In the following step, removal of the fuel cells is not required unless there is evidence of fuel leakage or damage to the fuel cells or structure is suspected. Structure that is hidden by the fuel cells only needs to be inspected if the fuel cells are removed for some reason or structural damage is suspected.</p> <p>25. All structure under floor panels and in aft fuel cell cavities including caps, angles, and panels between FS 155.06 and 200.00 for damage, corrosion, cracks, and voids.</p> <p>26. Bottom skin, FS 23.00 to 243.937, for damage. Joints for corrosion. Access panels and covers for condition and attachment.</p> <p>27. Main transmission compartment interior, FS 129.00 to 166.00 and WL 7.44 to 76.00, for corrosion. Bulkheads and main beam panels for damage and corrosion. Attaching supports and brackets for condition and security.</p> <p>28. Fluid lines in transmission compartment for evidence of leaks, condition, wear, and chafing. Clamps for condition (fluid contamination and swelling), and security of attachment.</p> <p>29. Lift beam fitting for condition and working rivets, lift link attachment bolt hole bores for excessive wear, and bushings for looseness.</p> <p>30. Pylon (transmission) support structure for wear and cracks. Pay particular attention to right and left horizontal supports, forward vertical supports, and aft vertical webs.</p> <p>31. Aft cabin bulkheads, FS 166.00, for damage, upper aft flange for cracks, and bulkhead panel for damage and disbonding.</p> <p>32. Electrical/avionics compartment, FS 166.00 to 243.937, doors for condition and security. Door frames for cracks and corrosion. Compartment interior for condition and joints for corrosion. Skin for damage and cracks.</p>		



SCHEDULED INSPECTIONS

5-15. 5000 HOURS/5 YEARS INSPECTION — PART B (CONT)

DATA REFERENCE	INSPECTION TASK DESCRIPTION	INITIAL	
		MECH	OTHER
Chapter 53	<p>33. Oil cooler compartment, FS 166.00 to 243.937, doors for condition and security. Main beam panels and bulkheads for condition and corrosion.</p> <p>34. Engine deck below the reduction gearbox, FS 211.00 to 238.00 for damage, cracks, and corrosion.</p> <p>35. Firewalls, FS 155.06 to 241.22, for damage, cracks, security of attachment, seals for condition, and seal attachment angles for cracks.</p> <p>36. Cabin roof, FS 35.00 to 166.00 above WL 68.00, BL 50.00 left and right side, for damaged skin and joints for corrosion, bonded panels for disbonding and corrosion. Structure above overhead console (circuit breaker panels) for cracks and corrosion.</p> <p>37. Cargo door tracks for wear, cracks, and corrosion.</p> <p>38. Engine and transmission cowlings and fairings for evidence of chafing, cracks, corrosion, and seals for condition.</p> <p>39. Bulkhead, FS 241.22, for damage, corrosion, and cracks. Tailboom attachment fittings for damage, cracks, and loose fasteners. Tailboom attachment bolt holes for damage and corrosion.</p> <p>40. Tailboom attachment bolts for damage, wear, and corrosion.</p> <p><u>TAILBOOM</u></p> <p>1. Bulkhead, BS 17.42, for corrosion and cracks. Fuselage attachment bolt holes for damage and corrosion. Barrel nuts for damage and corrosion.</p> <p>2. Tailboom and fin driveshaft covers for condition and attachment.</p> <p>3. Tailboom and fin external skin for damage, corrosion, and cracks.</p> <p>4. Tailboom access panels and covers for condition and attachment. Tail rotor driveshaft cover hinges for wear.</p>		

**SCHEDULED INSPECTIONS****5-15. 5000 HOURS/5 YEARS INSPECTION — PART B (CONT)**

DATA REFERENCE	INSPECTION TASK DESCRIPTION	INITIAL	
		MECH	OTHER
	<p>5. Tailboom baggage compartment door for condition, attachment, and door handle operation.</p> <p>6. Tailboom baggage compartment interior for damage, panels for disbonding, and corrosion. Longerons above roof panel for corrosion and cracks. Longerons below floor panel for corrosion and cracks.</p> <p>7. Tailboom interior bulkheads and stringers for cracks and corrosion.</p> <p>8. Intermediate gearbox mount pad for damage, cracks, fretting, and corrosion.</p> <p>9. Tail rotor gearbox support fitting assembly for damage, cracks, fretting, and corrosion. Pay particular attention to mounting holes and lugs.</p> <p>10. Tailboom exterior bonded panels adjacent to baggage compartment for damage, delamination, and corrosion.</p> <p>11. With a borescope or equivalent, inspect interior structure of vertical fin for cracks, corrosion, fretting, and damage.</p> <p>12. Control tube fairleads (grommets and guides) for wear and security of attachment.</p>		

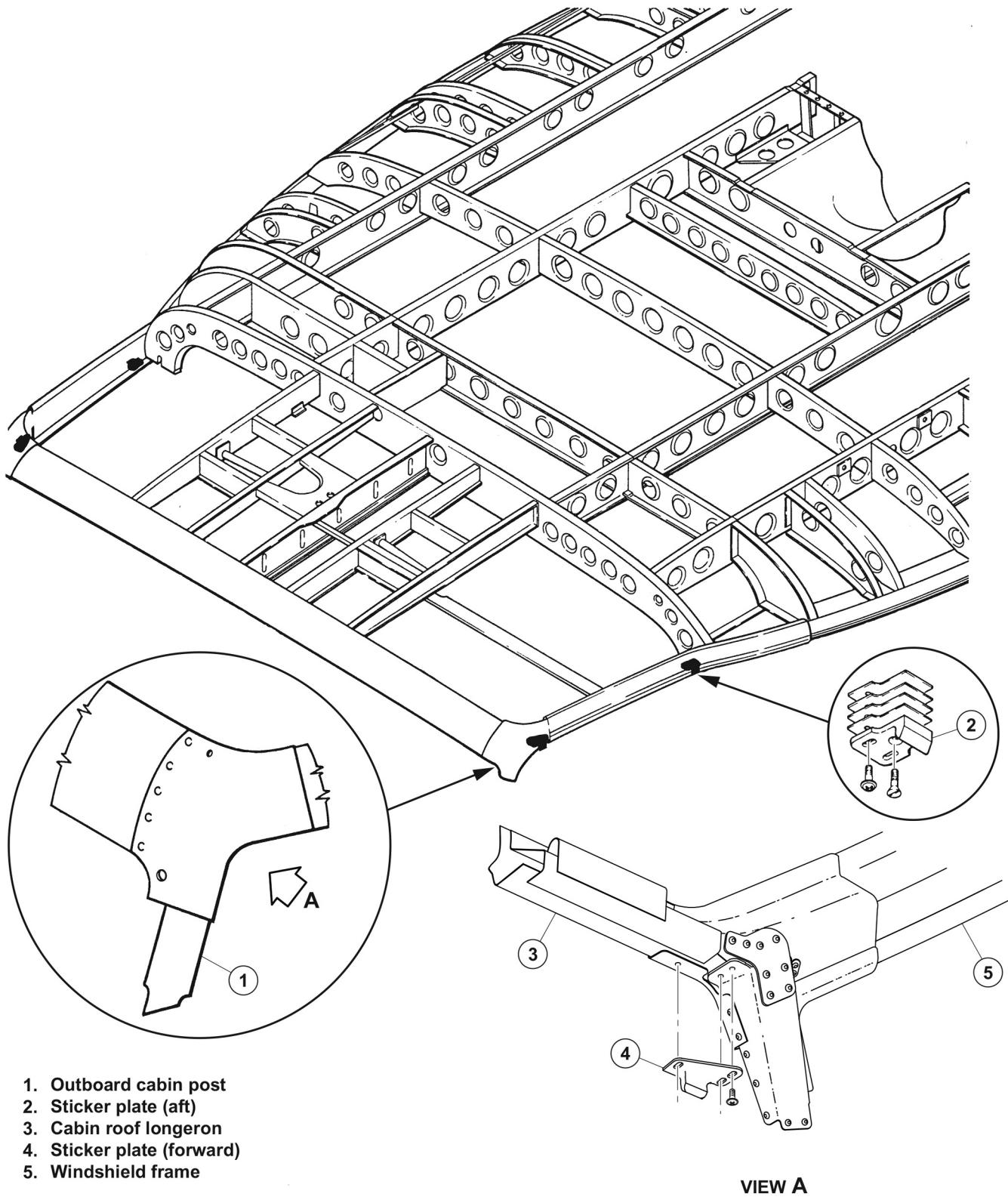

- 1. Outboard cabin post
- 2. Sticker plate (aft)
- 3. Cabin roof longeron
- 4. Sticker plate (forward)
- 5. Windshield frame

VIEW A

212_MM_05_0002a

Figure 5-3. Cabin Frame Inspection — Part B



SPECIAL INSPECTIONS

5-16. SPECIAL INSPECTION

Perform applicable special inspection of helicopter:

1. Daily inspection.
2. Daily or each 10 hours of flight, whichever occurs first until 250 hours.
3. Between 5 and 10 hours of flight after each installation.
4. Fin spar cap inspection every 8 hours.
5. Each 25 hours for the next four inspections.
6. Each 25 hours of flight operation.
7. Each seven days in a corrosive environment and each 30 days in a noncorrosive environment.
8. 50 hours after installation of components.
9. Each 50 hours of component operation.
10. Deleted.
11. Each 100 hour/12 calendar months of transmission operation.
12. Each 100 hours/12 months of intermediate gearbox operation.
13. Each 100 hours/12 months of tail rotor gearbox operation.
- 13A. Fin spar cap inspection every 100 hours.
14. Each 100 hours/12 months of battery system operation.
15. 100 hours after installation of tailboom.
16. Each 150 hours of starter generator operation.
17. Fin spar cap inspection every 300 hours.
18. Each 300 hours/12 months of transmission operation.
- 18A. Each 300 hours/12 months inspection of tail rotor control tube and bearing.
19. Each 300 hours/3 months of driveshaft operation.
20. Main rotor grip ultrasonic inspection.
21. Each 500 hours or 6 months of blade service.
22. Each 600 hours of transmission operation.
23. Each 600 hours/12 months of tail rotor driveshaft coupling operation.
24. Each 600 hours/12 months of main driveshaft operation.
25. Each 1000 hours of component operation.
26. First 1000 hours of component time and each 3000 hours thereafter of component time.
27. Each 1000 hours/12 months of main rotor blade operation.
28. Each 1200 hours/24 months of component operation.
29. Deleted.
30. Each 24 months of flight control system bolt operation.
31. Each 3000 hours of component operation.
32. Each 10,000 hour total airframe time and each 300 hours/12 months of main beam cap operation.
33. 10 years collective stick tube inspection.

Use the following time frame criteria when accomplishing the required Maintenance Manual torque checks after installation of components.

NOTE

Torque check is the term used when the specified torque or standard torque plus tare torque is applied to a fastener in a tightening direction. The specified or standard torque plus tare torque would have been previously recorded. However, if the specified or standard torque and tare were not recorded, use the minimum specified or standard torque, plus the tare torque listed in the BHT-ALL-SPM, Chapter 2.

Looseness may occur until components seat themselves and fasteners are tightened. This is not cause for disassembly, however the fastener will have to be torque checked again at the same scheduled interval set for the first torque check until the assembly is completely seated.

For additional information, refer to BHT-ALL-SPM. If any confusion exists, or a clarification is desired, contact Product Support Engineering.

Torque Check Requirements

MANUAL SPECIFIES	SUGGESTED TIME FRAME TO ACCOMPLISH
100 hours	90 to 110 hours
50 hours	40 to 60 hours
25 hours	20 to 30 hours
10 hours	5 to 15 hours



SPECIAL INSPECTIONS

5-17. DAILY INSPECTION

DATA REFERENCE	INSPECTION TASK DESCRIPTION	INITIAL	
		MECH	OTHER
Chapter 62	<p>DATE: _____ W.O. _____</p> <p>FACILITY: _____</p> <p>HELICOPTER S/N: _____</p> <p>REGISTRY NO.: _____</p> <p>TOTAL TIME: _____</p> <p>SIGNATURE: _____</p> <p><u>MAIN ROTOR HUB GRIP 204-011-121-009</u></p> <p>— Detailed Visual Inspection</p> <p>1. For 204-011-121-009 main rotor grip, inspect grip barrels both leading and trailing sides for evidence of hairline cracks (Figure 5-4).</p> <p>2. Deleted.</p> <p><u>TAIL FIN</u></p> <p>— Inspect</p> <p>1. Helicopters modified by TB 212-91-138 — If TB 212-88-104 has not been incorporated, inspect right tail fin skin for cracks.</p>		

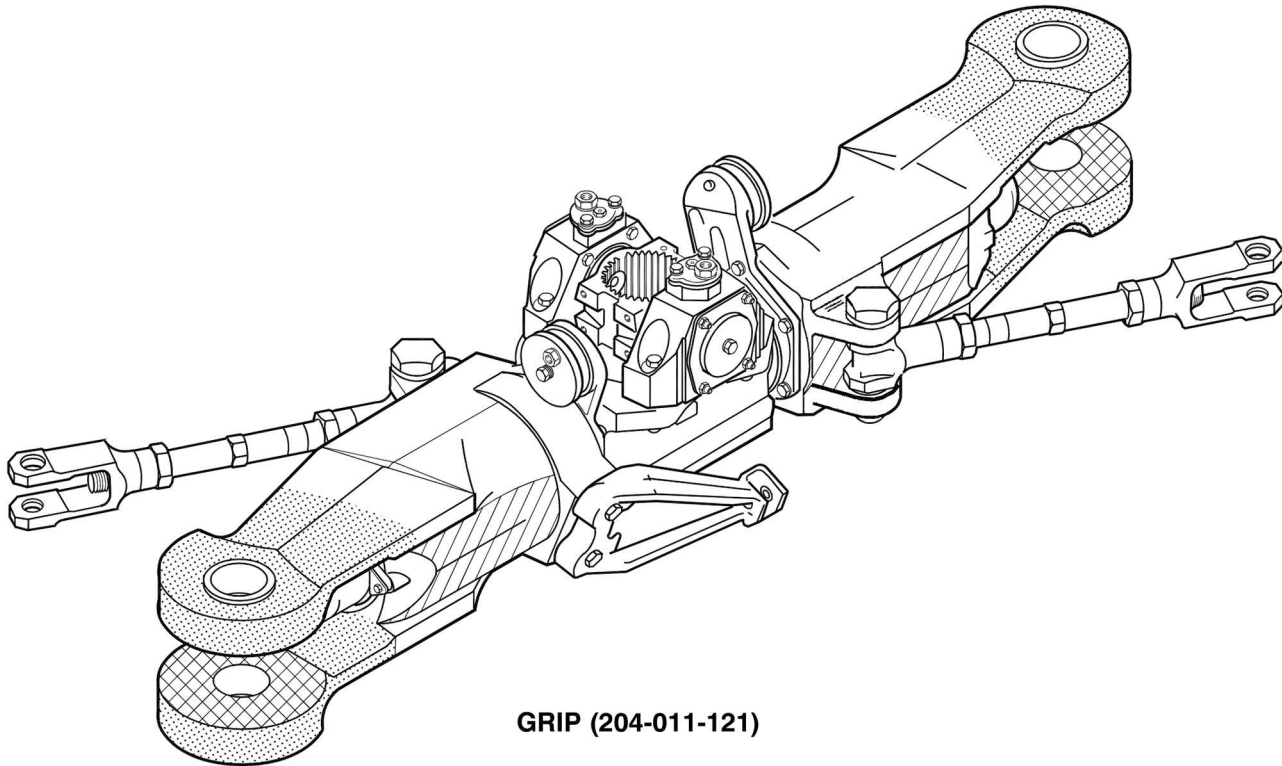

GRIP (204-011-121)

- 1  **AREA TO BE INSPECTED
UPPER AND LOWER TANGS
ALL EXPOSED SURFACES**
- 2  **AREA TO BE INSPECTED
GRIP BARREL LEADING
AND TRAILING SIDES
EXPOSED SURFACE (-009
GRIP ONLY)**

NOTES

- 1. **Inspect every 25 hours for all grips.**
- 2. **Inspect daily for grip (204-011-121-009) only.**

212_MM_05_0008_c01

Figure 5-4. Inspection of Main Rotor Hub Grip Tangs, Barrel and Drag Brace Attachment Lugs

SPECIAL INSPECTIONS

5-18. DAILY OR EACH 10 HOURS OF FLIGHT OPERATION, WHICHEVER OCCURS FIRST UNTIL 250 HOURS

DATA REFERENCE	INSPECTION TASK DESCRIPTION	INITIAL MECH OTHER	
<p>Chapter 63 and ASB 212-89-54</p>	<p>DATE: _____ W.O. _____</p> <p>FACILITY: _____</p> <p>HELICOPTER S/N: _____</p> <p>REGISTRY NO.: _____</p> <p>TOTAL TIME: _____</p> <p>SIGNATURE: _____</p> <p style="text-align: center;">NOTE</p> <p>Accomplish daily or each 10 hours flight operation, whichever occurs first until 250 hours, on transmission with affected gears with 50 hours or more.</p> <p><u>SPIRAL BEVEL GEAR 204-040-701-103</u></p> <p>— Inspect</p> <p style="text-align: center;">NOTE</p> <p>This inspection is only applicable to transmissions/ helicopters with the spiral bevel gears, shown in Figure 5-5, installed.</p> <p>1. Remove and inspect the transmission internal sump filter for metal contamination. If metal contamination is evident, notify Product Support Engineering of spiral bevel gear serial number, hours, and type of contamination.</p> <p>2. Every 50 hours (until 250 hours), visually inspect spiral bevel gear.</p> <p style="padding-left: 20px;">a. Remove quill pad cover (204-040-174-001) or rotor brake quill from transmission.</p>		

SPECIAL INSPECTIONS

5-18. DAILY OR EACH 10 HOURS OF FLIGHT OPERATION, WHICHEVER OCCURS FIRST UNTIL 250 HOURS (CONT)

DATA REFERENCE	INSPECTION TASK DESCRIPTION	INITIAL MECH OTHER	
	<p>b. Utilizing port opening in main gear case and a bright light and mirror, inspect all 62 teeth in spiral bevel gear, P/N 204-040-701-103. Carefully inspect each tooth for evidence of chipping or loss of material (Figure 5-6).</p> <p>c. Remove and replace any gear not meeting inspection requirements set forth in step b. Notify Product Support Engineering of serial number and total time of any gear replaced.</p> <p>d. Install quill pad cover or rotor brake quill.</p> <p>3. Spare (uninstalled) affected spiral bevel gears.</p> <p>a. Return spare affected serial numbered spiral bevel gears to Bell Helicopter Textron for inspection and reidentification. Refer to Information Letter IL GEN-04-98 for shipping instructions.</p>		

A-3819	A-3896	A-4085	A-4243	A-4368
A-3821	A-3897	A-4087	A-4244	A-4369
A-3825	A-3899	A-4089	A-4245	A-4370
A-3826	A-3901	A-4090	A-4254	A-4371
A-3829	A-3911	A-4091	A-4266	A-4372
A-3833	A-3915	A-4092	A-4267	A-4374
A-3834	A-3916	A-4093	A-4274	A-4376
A-3836	A-3919	A-4094	A-4275	A-4377
A-3838	A-3920	A-4095	A-4280	A-4378
A-3840	A-4008	A-4096	A-4282	A-4379
A-3845	A-4014	A-4097	A-4288	A-4380
A-3847	A-4017	A-4098	A-4289	A-4383
A-3848	A-4019	A-4107	A-4290	A-4385
A-3850	A-4020	A-4108	A-4303	A-4386
A-3855	A-4021	A-4109	A-4319	A-4387
A-3856	A-4027	A-4147	A-4320	A-4394
A-3857	A-4029	A-4184	A-4325	A-4395
A-3858	A-4068	A-4186	A-4327	A-4397
A-3861	A-4069	A-4187	A-4328	A-4400
A-3878	A-4071	A-4188	A-4329	A-4401
A-3880	A-4075	A-4191	A-4332	A-4403
A-3885	A-4077	A-4192	A-4333	A-4411
A-3886	A-4078	A-4193	A-4334	A-4417
A-3889	A-4079	A-4213	A-4335	A-4418
A-3891	A-4080	A-4233	A-4336	A-4428
A-3892	A-4081	A-4235	A-4337	
A-3893	A-4083	A-4236	A-4358	
A-3895	A-4084	A-4241	A-4366	

NOTE

Spiral bevel gears with the suffix "R" after the serial number are acceptable for service.

Transmissions/helicopters delivered with an affected serial numbered spiral bevel gear P/N 204-040-701-103.

<u>Bevel Gear</u>	<u>Serial Number Transmission</u>	<u>212</u>
A-3822	A-632	31305
A-3881	A-626	31304
A-4006	A-678	31307

212_MM_05_0010

Figure 5-5. Spiral Bevel Gears Serial Numbers

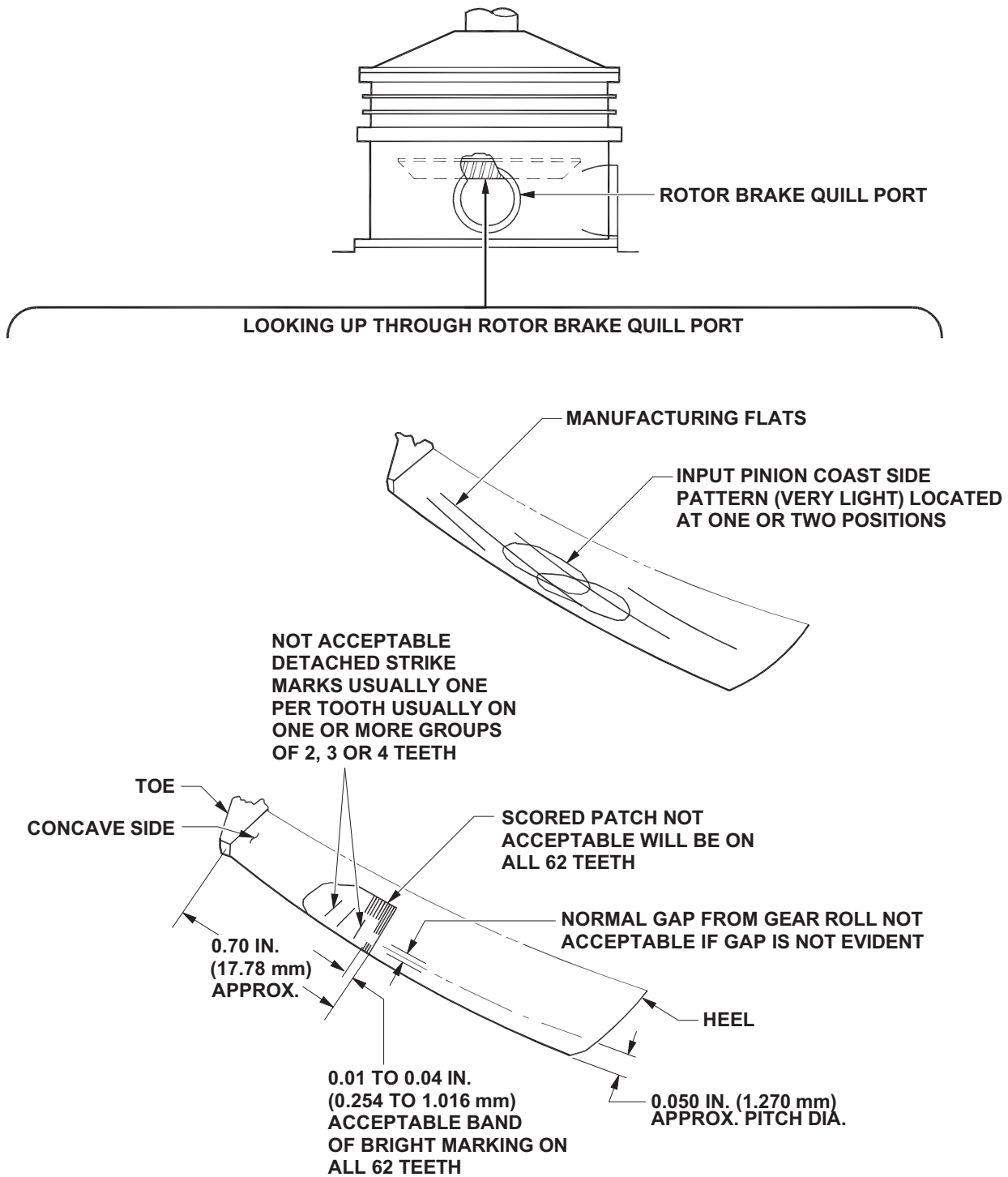

212_MM_05_0004

Figure 5-6. Inspection of Spiral Bevel Gear (Sheet 1 of 3)

REGISTRATION NO. _____

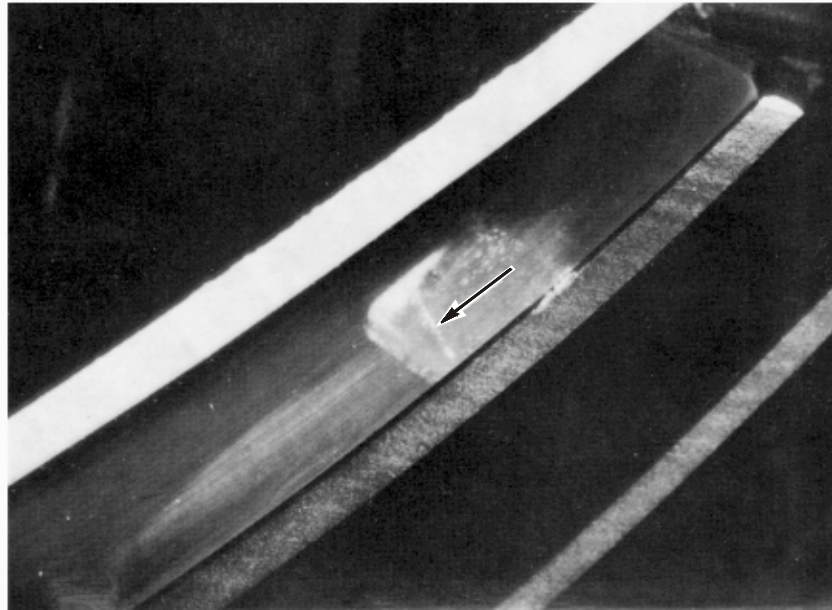

SPIRAL BEVEL GEAR (204-040-701) UNACCEPTABLE PATTERN

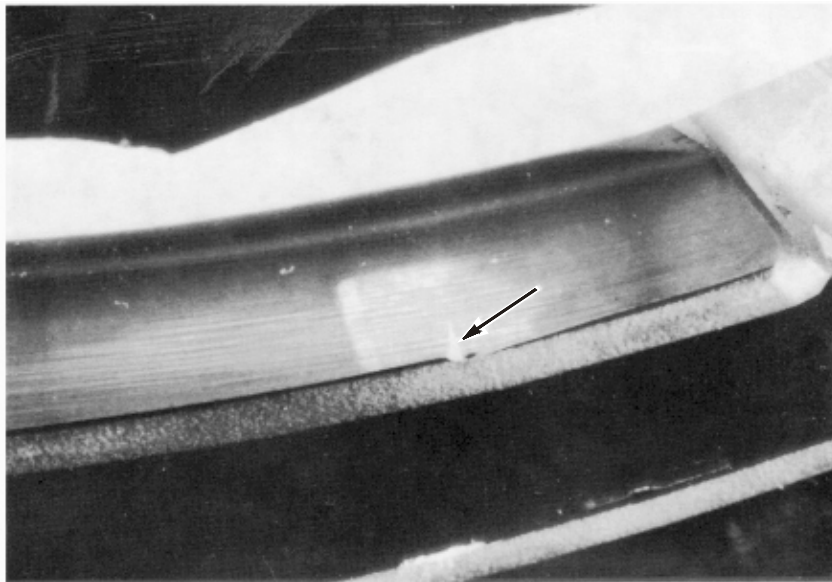

SPIRAL BEVEL GEAR (204-040-701) UNACCEPTABLE PATTERN

Figure 5-6. Inspection of Spiral Bevel Gear (Sheet 2 of 3)

212_MM_05_0005

REGISTRATION NO. _____

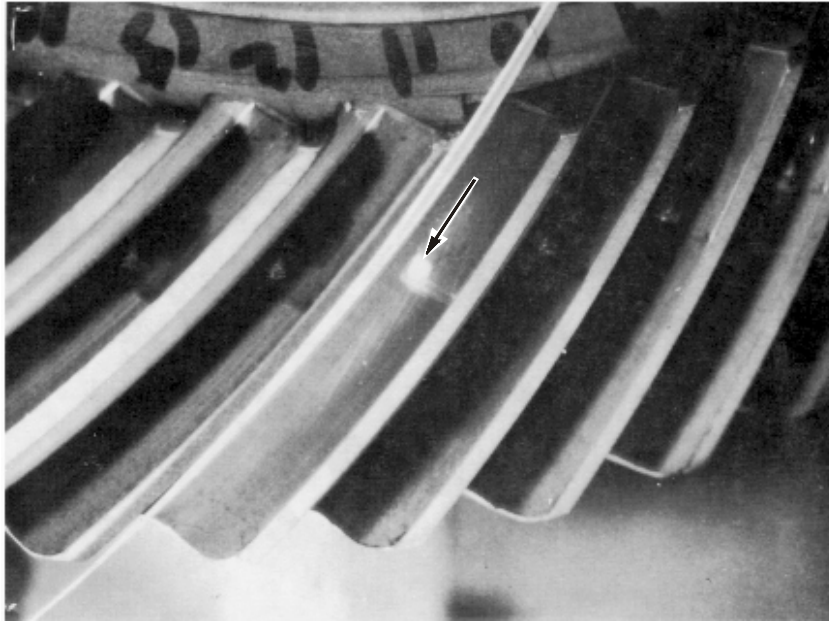

SPIRAL BEVEL GEAR (204-040-701) UNACCEPTABLE PATTERN

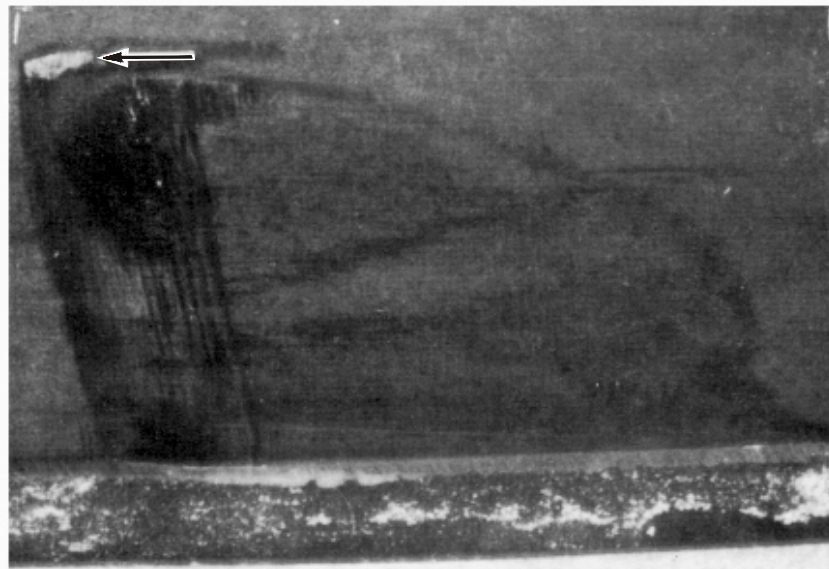

SPIRAL BEVEL GEAR (204-040-701) UNACCEPTABLE PATTERN

212_MM_05_0006

Figure 5-6. Inspection of Spiral Bevel Gear (Sheet 3 of 3)



SPECIAL INSPECTIONS

5-19. BETWEEN 5 AND 10 HOURS OF FLIGHT AFTER EACH INSTALLATION

DATA REFERENCE	INSPECTION TASK DESCRIPTION	INITIAL MECH OTHER	
<p>Chapter 62</p> <p>Chapter 64</p> <p>Chapter 65</p>	<p>DATE: _____ W.O. _____</p> <p>FACILITY: _____</p> <p>HELICOPTER S/N: _____</p> <p>REGISTRY NO.: _____</p> <p>TOTAL TIME: _____</p> <p>SIGNATURE: _____</p> <p style="text-align: center;">NOTE</p> <p style="text-align: center;">Accomplish between 5 and 10 hours of flight after each installation.</p> <p><u>MAIN ROTOR</u></p> <p>1. Torque check main rotor retaining nut 520 to 780 foot-pounds (705 to 1057 Nm).</p> <p>2. Main rotor hub blade attachment bolts, torque check nuts 260 to 300 foot-pounds (353 to 407 Nm).</p> <p><u>TAIL ROTOR HUB AND BLADE ASSEMBLY</u></p> <p>1. Torque check tail rotor retaining nut 900 inch-pounds (101.69 Nm).</p> <p><u>TAIL ROTOR GEARBOX</u></p> <p>Torque check tail rotor gearbox retaining nuts 200 to 235 inch-pounds (22.60 to 26.55 Nm). Using a 0.005 inch (0.127 mm) or less feeler gauge, verify no gap exists between gearbox input quill shim and gearbox case shim.</p>		

SPECIAL INSPECTIONS

5-19. BETWEEN 5 AND 10 HOURS OF FLIGHT AFTER EACH INSTALLATION (CONT)

DATA REFERENCE	INSPECTION TASK DESCRIPTION	INITIAL	
		MECH	OTHER
Chapter 65	<p><u>INTERMEDIATE GEARBOX</u></p> <p>Torque check intermediate gearbox retaining bolts 50 to 70 inch-pounds (5.65 to 7.91 Nm).</p>		

SPECIAL INSPECTIONS

5-20. FIN SPAR CAP INSPECTION EVERY 8 HOURS

DATA REFERENCE	INSPECTION TASK DESCRIPTION	INITIAL MECH OTHER	
ASB 212-00-110	<p>DATE: _____ W.O. _____</p> <p>FACILITY: _____</p> <p>HELICOPTER S/N: _____</p> <p>REGISTRY NO.: _____</p> <p>TOTAL TIME: _____</p> <p>SIGNATURE: _____</p> <p>1. Accomplish inspection of fin spar caps P/N 212-030-125-001, 212-030-447-001 and 212-030-447-101 every 8 flight hours.</p> <p>2. This special inspection is not required if fin spar cap P/N 212-030-447-117 has been installed as original equipment or in accordance with TB 212-00-184.</p> <p>3. Fin spar cap P/N 212-030-447-117 can be identified by the presence of decals that identify the cold-worked holes.</p> <p><u>FIN SPAR CAP 212-030-125-001 AND 212-030-447-001/101</u></p> <p>1. Carry out 8 hour recurring inspection in accordance with applicable section of ASB 212-00-110.</p> <p>2. Any discrepancies (cracks, corrosion, debonding, or other damage) are to be reported to Product Support Engineering before further flight.</p>		

SPECIAL INSPECTIONS

5-21. EACH 25 HOURS FOR THE NEXT FOUR INSPECTIONS

DATA REFERENCE	INSPECTION TASK DESCRIPTION	INITIAL MECH OTHER	
<p>ASB 212-95-95 Revision C</p>	<p>DATE: _____ W.O. _____</p> <p>FACILITY: _____</p> <p>HELICOPTER S/N: _____</p> <p>REGISTRY NO.: _____</p> <p>TOTAL TIME: _____</p> <p>SIGNATURE: _____</p> <p><u>TAIL ROTOR HANGER BEARINGS WITNESS MARKS</u></p> <p style="text-align: center;">NOTE</p> <p>Accomplish visual inspection of witness marks (only applicable to hanger bearings 204-040-623-003 and -005) each 25 flight hours for the next four inspections after installation or initial inspection of hanger bearings.</p> <p style="text-align: center;">NOTE</p> <p>All newly installed hanger bearings must contain a scribe or paint witness mark and will require an initial inspection.</p> <p>1. Perform helicopter run-up for 5 minutes. Shut down helicopter and inspect tail rotor hanger bearings for movement of the dust shields, identified by breakage of the witness marks. Remove any bearings from service that display dust shield movement.</p> <p>2. Hanger bearings not displaying movement at the run-up may remain in service, but must be inspected for dust shield movement at each of the next four mandatory 25 hour inspections, or any time the bearing is inspected between any of the 25 hour inspections. Bearings that do not display grease shield movement after the fourth 25 hour inspection may remain in service with no further inspection required. Record accomplishment of inspection in the helicopter log book.</p>		

SPECIAL INSPECTIONS

5-21. EACH 25 HOURS FOR THE NEXT FOUR INSPECTIONS (CONT)

DATA REFERENCE	INSPECTION TASK DESCRIPTION	INITIAL	
		MECH	OTHER
	3. Remove any hanger bearing from service where the witness marks indicate that the grease shield has moved.		

SPECIAL INSPECTIONS

5-22. EACH 25 HOURS OF FLIGHT OPERATION

DATA REFERENCE	INSPECTION TASK DESCRIPTION	INITIAL MECH OTHER	
Chapter 62	<p>DATE: _____ W.O. _____</p> <p>FACILITY: _____</p> <p>HELICOPTER S/N: _____</p> <p>REGISTRY NO.: _____</p> <p>TOTAL TIME: _____</p> <p>SIGNATURE: _____</p> <p style="text-align: center;">NOTE</p> <p style="text-align: center;">Accomplish each 25 flight hours of operation.</p> <p><u>SWASHPLATE GIMBAL RING BOLTS</u></p> <p style="text-align: center;">NOTE</p> <p>This swashplate gimbal ring bolt special inspection is applicable to helicopters on Part A scheduled inspection program only. The intent of this special inspection is included in the 25 hour/30 day inspection — Part B.</p> <p>Do not attempt to turn bolts or nuts. Bolt rotation will fail loctite in joint and permit bolt wear.</p> <p>The presence of black oxide powder will require investigation to determine the cause.</p> <p>— Inspect</p> <p>1. Grasp swashplate rotating ring, 204-011-403, and attempt to move it in a horizontal plane on an axis in line with gimbal ring attach points to support assembly, 204-011-404. Maximum allowable axial looseness across gimbal ring bearings and attaching bolts is 0.005 inch (0.127 mm).</p>		

SPECIAL INSPECTIONS

5-22. EACH 25 HOURS OF FLIGHT OPERATION (CONT)

DATA REFERENCE	INSPECTION TASK DESCRIPTION	INITIAL	
		MECH	OTHER
Chapter 62	<p>2. Repeat step 1 on axis 90° and attempt to detect looseness in line with gimbal ring attach points to inner ring. Maximum allowable axial looseness across the gimbal ring bearing and attaching bolts is 0.005 inch (0.127 mm).</p> <p><u>204-011-451 TRUNNION INSTALLED IN 204-011-403 SWASHPLATE ROTATING RING</u></p> <p>— Detailed Visual Inspection</p> <p>1. Check trunnions for excessive axial looseness.</p>		
Chapter 62 ASB 212-08-130	<p><u>MAIN ROTOR HUB GRIP 204-011-121</u></p> <p>— Detailed Visual Inspection</p> <p>1. Prepare both main rotor grip tangs for inspection by cleaning exposed surfaces with denatured alcohol (C-326) as per the BHT-ALL-SPM. Wipe dry.</p> <p>2. Inspect grip surfaces for evidence of hairline cracks on grip barrels and upper and lower tangs exposed surfaces. Pay particular attention to the lower tang lower surface from blade bolt bushing flange to the trailing and leading edge of the tang (Figure 5-4).</p> <p><u>MAIN ROTOR BLADE</u></p> <p>1. Wash upper and lower main rotor blade surfaces with a solution of cleaning compound (C-318) and water. Rinse thoroughly and wipe dry.</p> <p style="text-align: center;">NOTE</p> <p style="text-align: center;">Accomplishment of this inspection does not require removal of the blades from the main rotor hub.</p>		



SPECIAL INSPECTIONS

5-22. EACH 25 HOURS OF FLIGHT OPERATION (CONT)

DATA REFERENCE	INSPECTION TASK DESCRIPTION	INITIAL MECH OTHER	
	<div data-bbox="743 457 945 546" style="text-align: center;"> <p>CAUTION</p> </div> <p data-bbox="571 583 1195 751">FOR INSPECTION OF THE BLADE ON THE LOWER SIDE, THE BLADE MUST BE SUPPORTED AT THE TIP TO REMOVE ANY BOW. FAILURE TO SUPPORT THE BLADE ADEQUATELY MAY RENDER CHORDWISE CRACKS DIFFICULT TO DETECT.</p> <p data-bbox="508 793 1260 966">2. Inspect the main rotor blade upper and lower grip plates and doublers for their entire length and chord width. Inspect for signs of cracks, corrosion, and edge voids, paying particular attention to the bond lines between doublers, grip plates, and skin. Hair line cracks in the paint finish should be suspect for possible cracks/voids.</p> <p data-bbox="508 1003 1260 1092">3. Wipe the area between blade stations 24.5 and 85.0 with a clean cloth (C-516) soaked with isopropyl alcohol (C-385). Wipe dry with a clean cloth (C-516).</p> <div data-bbox="847 1140 925 1165" style="text-align: center;"> <p>NOTE</p> </div> <p data-bbox="571 1188 1195 1390">Accomplish step 4 immediately after carrying out the above alcohol wipe. Any potential cracks in the bond lines between doublers or grip plates will be indicated by the presence of excess alcohol bleeding out of an edge void. The excess alcohol in the void will appear as a dark line between the bond lines of the doublers.</p> <div data-bbox="847 1442 925 1467" style="text-align: center;"> <p>NOTE</p> </div> <p data-bbox="571 1491 1195 1633">When inspecting the blade for cracks, the strong light source should be applied at an oblique angle and perpendicular to the crack orientation we attempt to detect. For example, for a chordwise crack, the light source should be applied in a spanwise direction.</p> <div data-bbox="786 1688 987 1776" style="text-align: center;"> <p>CAUTION</p> </div> <p data-bbox="571 1799 1195 1887">DO NOT TO REMOVE ANY PARENT MATERIAL FROM THE SKIN/DOUBLERS DURING SANDING OPERATION.</p>		



SPECIAL INSPECTIONS

5-22. EACH 25 HOURS OF FLIGHT OPERATION (CONT)

DATA REFERENCE	INSPECTION TASK DESCRIPTION	INITIAL MECH OTHER	
	<p>4. Carry out a detailed visual inspection of the top and bottom of the blade between blade stations 24.5 and 85.0 using a 3X magnifying glass and a strong light source. Check for evidence of a dark line between doublers, grip plates, and skin with excess alcohol bleeding out of possible edge voids. Any cracks in the finish must be investigated further by removing paint in affected areas (sand with 180-220 grit abrasive paper (C-423) in a spanwise direction) to determine if the grip plate/doublers are cracked or voided. Any crack in paint finish that follows grip plate/doubler outline may indicate a possible edge void.</p> <p>5. Carry out a detailed visual inspection of the top and bottom of the blade between blade stations 26.0 and 30.0 in the blade bolt area with a 10X power magnifying glass and a strong light source. Inspect the leading edge and trailing edge sides of the blade at the blade bolt span station for evidence of cracks or dark lines in the grip plates going across the doublers. Any cracks in the finish must be investigated further by removing paint in the affected areas. Sand the affected area in a spanwise direction with an abrasive cloth or paper (C-406) 180 to 220 grit to determine if the grip plate/doublers are cracked or voided.</p> <p>6. If cracks in grip plate/doublers are found, immediately remove the main rotor blade from service and contact Product Support Engineering. If no cracks are detected, continue with step 7.</p> <div style="text-align: center;">  <p>CAUTION</p> <p>DO NOT TO REMOVE ANY PARENT MATERIAL FROM THE SKIN/DOUBLERS DURING SANDING OPERATION.</p> </div> <p>7. If edge voids between grip plate/doublers/skin are found, determine depth and length by using 0.0015 inch (0.038 mm) feeler gauge. If edge voids are near outboard tip of grip plate / doublers, also carefully tap inspect suspect area. Refer to BHT-212-CR&O, Chapter 62 for void repair limits and inspection/repair instructions. If no voids are detected, continue with step 8.</p>		



SPECIAL INSPECTIONS

5-22. EACH 25 HOURS OF FLIGHT OPERATION (CONT)

DATA REFERENCE	INSPECTION TASK DESCRIPTION	INITIAL MECH OTHER	
<p>Chapter 64</p> <p>ASB 212-96-100 and ASB 212-96-101</p>	<p>8. Refinish the sanded area as per BHT-212-MM-6, Chapter 62.</p> <p>9. Following the inspection, apply a light coat of preservative oil (C-125) to all surfaces of blade.</p> <p><u>TRANSMISSION MAIN CASE 204-040-353</u></p> <p>1. Inspect main case web above the input quill at the 12 o'clock position that has been previously reworked per the BHT-212-CR&O-3 by doing the following:</p> <p style="padding-left: 40px;">a. Visually inspect for signs of oil leakage in case wall. If noted, remove assembly and do an NDI on the case assembly.</p> <p style="padding-left: 40px;">b. If no leakage is noted, thoroughly clean the area with alcohol/naphtha and visually inspect with minimum 3X magnifying glass for signs of cracks.</p> <p style="padding-left: 40px;">c. Any crack is cause for immediate replacement of main case.</p> <p><u>TAIL ROTOR HUB ASSEMBLY</u></p> <p>— Detailed Visual Inspection</p> <p>1. Flapping bearings 212-010-723-001 or 212-010-768-001 exposed outer races for cracks using a 3X magnifying glass. Any crack is cause for immediate replacement of both bearings.</p> <p>2. Inspect tail rotor yoke 212-010-704, 212-010-744, or 212-011-702.</p> <p><u>TAIL ROTOR STATIC STOP</u></p> <p>1. Inspect flapping stop 212-010-738 or 212-011-713 for yielding as noted in Chapter 64, to determine if tail rotor yoke assembly may have been exposed to bending.</p> <p>If any doubt exists as to the serviceability of these components, contact Product Support Engineering.</p>		



SPECIAL INSPECTIONS

5-22. EACH 25 HOURS OF FLIGHT OPERATION (CONT)

DATA REFERENCE	INSPECTION TASK DESCRIPTION	INITIAL	
		MECH	OTHER
Chapter 64	<p><u>TAIL ROTOR BLADE</u></p> <ol style="list-style-type: none"> 1. Clean each tail rotor blade by hand using mild soap and cheesecloth (C-486) in a spanwise direction; dry thoroughly. 2. Carry out a detailed visual inspection of both sides of the entire blade with a 3X magnifying glass, or higher, and a bright light. Inspect the tail rotor blade skin, leading edge spar, doublers, grip plates, and trailing edge for cracks, corrosion, nicks, dents, and scratches. Refer to Chapter 64 for damage limits. 3. If any blistering, peeling, flaking, bubbling, or cracked paint is detected, remove the paint from the affected area and visually inspect the affected area for corrosion or a crack using a 10X magnifying glass, or higher. If any corrosion is found, measure the depth of the corrosion. 4. Only superficial corrosion that can be removed with aluminum wool or very fine grade abrasive pad (C-407) is permissible. Corrosion on the spar 0.003 inch (0.076 mm) deep or less is acceptable when polished out. Replace any blade that has corrosion on the spar greater than 0.003 inch (0.076 mm). 5. If a nick, scratch, or dent is found, visually inspect for crack using a 10X magnifying glass, or higher, and measure the depth of the damage. (A digital optical micrometer is one tool that can be used for this measurement). 6. Repair damage and/or corrosion found on tail rotor blades in accordance with Chapter 64. 7. Replace any blade that has a crack. No cracks are permitted. <p style="text-align: center;">NOTE</p> <p style="text-align: center;">Removal of the tail rotor blades is not required for the following inspection.</p>		
ASB 212-13-147	<ol style="list-style-type: none"> 8. Carry out a further detailed inspection of both sides of the blade between stations 20.00 to 35.00 (Figure 5-6A), with a 10X magnifying glass and a bright light. 		

SPECIAL INSPECTIONS

5-22. EACH 25 HOURS OF FLIGHT OPERATION (CONT)

DATA REFERENCE	INSPECTION TASK DESCRIPTION	INITIAL MECH OTHER	
	<p>9. If any blistering, peeling, flaking, bubbling, or cracked paint is detected, remove the paint from the affected area by sanding in a spanwise direction only with an abrasive cloth or paper (C-406) 240 grit or finer and a final sanding using an abrasive cloth or paper (C-406) 400-grit or finer. After paint removal, visually inspect the affected area for damage using a 10X magnifying glass. Damage beyond the limits given in Chapter 64 requires blade removal from service.</p> <p>10. Only superficial corrosion that can be removed with aluminum wool or very fine grade abrasive pad (C-407) is permissible. Corrosion on the spar 0.003 inch deep or less is acceptable when polished out. Replace any blade that has corrosion on the spar greater than 0.003 inch.</p> <p>11. If a nick, scratch, or dent is found, visually inspect for crack using a 10X magnifying glass, or higher, and measure the depth of the damage. (A digital optical micrometer is one tool that can be used for this measurement).</p> <p>12. Repair damage and/or corrosion found on tail rotor blades in accordance with Chapter 64.</p> <p>13. Replace any blade that has a crack. No cracks are permitted.</p> <p>14. If paint was removed during the above steps, carry out paint touch up/refinishing in accordance with Chapter 64.</p>		

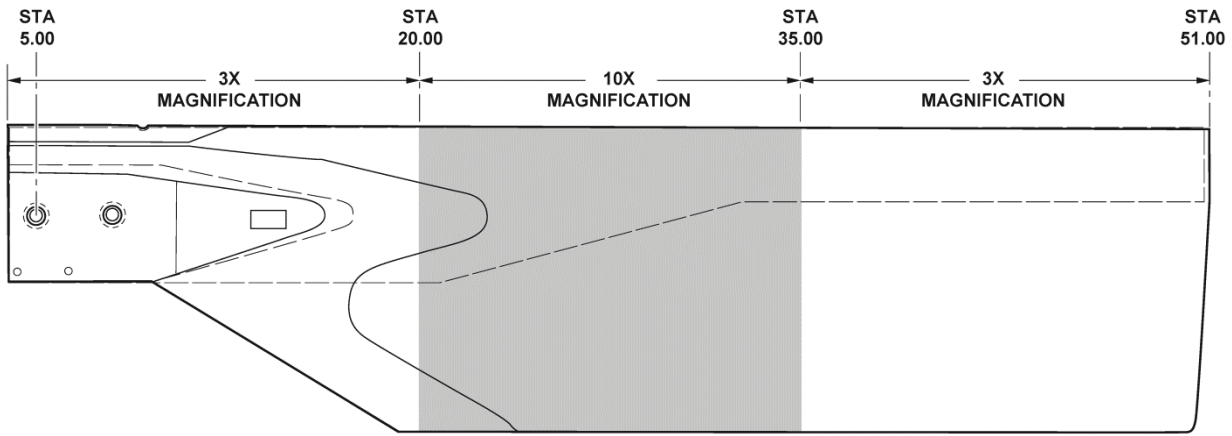

212_MM_05_0006a

Figure 5-6A. Tail Rotor Blade - Detailed Inspection



SPECIAL INSPECTIONS

5-23. EACH SEVEN DAYS IN A CORROSIVE ENVIRONMENT AND EACH 30 DAYS IN A NONCORROSIVE ENVIRONMENT

DATA REFERENCE	INSPECTION TASK DESCRIPTION	INITIAL	
		MECH	OTHER
Chapter 62	DATE: _____ W.O. _____ FACILITY: _____ HELICOPTER S/N: _____ REGISTRY NO.: _____ TOTAL TIME: _____ SIGNATURE: _____		
	<p style="text-align: center;">NOTE</p> <p>Accomplish each seven days in a corrosive environment and each 30 days in a noncorrosive environment.</p> <p><u>MAIN ROTOR BLADES 204-012-001 AND 212-015-501</u></p> <p>— Clean</p> <ol style="list-style-type: none"> 1. Wash upper and lower surfaces with a solution of cleaning compound (C-318) and water. Rinse thoroughly and wipe dry. 2. Inspect surfaces for condition. 3. Apply a light coat of preservative oil (C-125) to surfaces of blade, including areas between main rotor hub grip tangs. 		

SPECIAL INSPECTIONS

5-24. 50 HOURS AFTER INSTALLATION OF COMPONENTS

DATA REFERENCE	INSPECTION TASK DESCRIPTION	INITIAL	
		MECH	OTHER
	<p>DATE: _____ W.O. _____</p> <p>FACILITY: _____</p> <p>HELICOPTER S/N: _____</p> <p>REGISTRY NO.: _____</p> <p>TOTAL TIME: _____</p> <p>SIGNATURE: _____</p> <p style="text-align: center;">NOTE</p> <p style="text-align: center;">Accomplish 50 flight hours after installation of components.</p>		
Chapter 53	<p><u>TAILBOOM</u></p> <p>Torque check anti-torque bellcrank support 212-001-706-001/101 attachment nuts 75 to 95 inch-pounds (8.47 to 10.73 Nm).</p>		
Chapter 63	<p><u>ROTOR BRAKE</u></p> <p>1. Torque check brake assembly (caliper) attachment bolts 80 to 100 inch-pounds (9.04 to 11.30 Nm).</p> <p>2. Torque check brake disc attachment bolts 50 to 70 inch-pounds (5.65 to 7.91 Nm).</p>		

SPECIAL INSPECTIONS

5-25. EACH 50 HOURS OF COMPONENT OPERATION

DATA REFERENCE	INSPECTION TASK DESCRIPTION	INITIAL MECH OTHER	
Chapter 63	<p>DATE: _____ W.O. _____</p> <p>FACILITY: _____</p> <p>HELICOPTER S/N: _____</p> <p>REGISTRY NO.: _____</p> <p>TOTAL TIME: _____</p> <p>SIGNATURE: _____</p> <p style="text-align: center;">NOTE</p> <p style="text-align: center;">Accomplish each 50 hours of component operation.</p> <p><u>TRANSMISSION</u></p> <p>— Detailed Visual Inspection</p> <p>1. Transmission 212-040-001-115, -119, -123, and -127 — remove internal filter and sump chip detector. Visually inspect filter element and detector for metallic chips, particles, and contamination. If contamination or debris is found, investigate to determine cause. Thoroughly clean and reinstall detector and filter. Service transmission oil system (Chapter 12) to proper level.</p> <p style="text-align: center;">NOTE</p> <p style="text-align: center;">Accomplish each 50 hours of component operation.</p>		
Chapter 65	<p><u>TAIL ROTOR PITCH CHANGE SHAFT (CROSSHEAD) BEARING 212-010-762-001</u></p> <p>— Inspect</p> <p style="text-align: center;">NOTE</p> <p style="text-align: center;">The following inspection does not apply to helicopter S/N 30712 and subsequent or to helicopter S/N 30711 and prior, after modification by SI 212-49.</p>		

SPECIAL INSPECTIONS

5-25. EACH 50 HOURS OF COMPONENT OPERATION (CONT)

DATA REFERENCE	INSPECTION TASK DESCRIPTION	INITIAL MECH OTHER	
<p>TB 212-76-18 TB 212-86-92 TB 212-91-132</p>	<p>1. Visually inspect bearing for indications of lubricant depletion, metal contamination, and bearing for roughness when rotated by hand. Rough bearing or metal contamination is cause for immediate replacement.</p> <p><u>HELICOPTERS MODIFIED BY TB 212-91-138</u></p> <p>If Technical Bulletins 212-76-18, 212-86-92 and 212-91-132 have not been incorporated, the following listed inspection is mandatory.</p> <ol style="list-style-type: none"> 1. Inspect lift beam caps for cracks. 2. Inspect L/H spar cap, fin for cracks. 3. Inspect lift link fitting for cracks. 		

SPECIAL INSPECTIONS

5-26. EACH 100 HOURS OF MAIN ROTOR BLADE OPERATION — DELETED

DATA REFERENCE	INSPECTION TASK DESCRIPTION	INITIAL	
		MECH	OTHER
	<p style="text-align: center;">NOTE</p> <p>The Each 100 Hours of Main Rotor Blade Operation special inspection has been moved to the Each 25 Hours of Flight Operation special inspection.</p>		



SPECIAL INSPECTIONS

5-27. EACH 100 HOURS/12 MONTHS OF TRANSMISSION OPERATION

DATA REFERENCE	INSPECTION TASK DESCRIPTION	INITIAL MECH OTHER	
Chapter 63	<p>DATE: _____ W.O. _____</p> <p>FACILITY: _____</p> <p>HELICOPTER S/N: _____</p> <p>REGISTRY NO.: _____</p> <p>TOTAL TIME: _____</p> <p>SIGNATURE: _____</p> <p style="text-align: center;">NOTE</p> <p style="text-align: center;">Accomplish each 100 hours or 12 months of transmission operation, whichever occurs first.</p> <p><u>TRANSMISSION</u></p> <p>— General Visual Inspection</p> <p style="text-align: center;">NOTE</p> <p>Step 1 applicable to helicopters S/N 30501 to 31206 with 10-micron external oil filter elements installed (PRE-TB 212-83-78).</p> <p>1. Helicopters with 10-micron external oil filters installed accomplish the following:</p> <ul style="list-style-type: none"> a. Drain transmission oil system. b. Replace external oil filter element. c. Remove sump screen and inspect for debris. d. If debris is found, determine and correct cause. e. Thoroughly clean and reinstall sump screen. f. Service transmission to proper level (Chapter 12). 		



SPECIAL INSPECTIONS

5-27. EACH 100 HOURS/12 MONTHS OF TRANSMISSION OPERATION (CONT)

DATA REFERENCE	INSPECTION TASK DESCRIPTION	INITIAL MECH OTHER	
	<div style="text-align: center; border: 2px dashed black; padding: 5px; width: fit-content; margin: 0 auto;"> <p>CAUTION</p> </div> <p>DO NOT SUBSTITUTE 10 MICRON FOR 3 MICRON FILTER ELEMENT FOR HELICOPTERS S/N 31207 AND SUBSEQUENT (AND HELICOPTERS MODIFIED BY TB 212-83-78).</p> <p style="text-align: center;">NOTE</p> <p>Step 2 applicable to helicopters S/N 31207 and subsequent (and helicopters modified by TB 212-83-78) which use 3-micron external oil filter element. The oil change, external filter replacement, sump screen removal and inspection for debris are extended to 1/2 transmission TBO interval or 12 months, whichever occurs first.</p> <p>2. Helicopters with 3-micron external oil filters installed accomplish the following:</p> <ul style="list-style-type: none"> a. Drain transmission oil system. b. Replace external oil filter element. c. Remove sump screen and inspect for debris. d. If debris is found, determine and correct cause. e. Thoroughly clean and reinstall sump screen. f. Service transmission to proper level (Chapter 12). <p>3. Deleted.</p> <p>4. Visually inspect the main case, 204-040-353-023, for cracks in web above input quill bore (using dye penetrant method if case has been previously reworked). Any crack indication is cause for replacement of case.</p>		



SPECIAL INSPECTIONS

5-28. EACH 100 HOURS/12 MONTHS OF INTERMEDIATE GEARBOX OPERATION

DATA REFERENCE	INSPECTION TASK DESCRIPTION	INITIAL MECH OTHER	
Chapter 12	<p>DATE: _____ W.O. _____</p> <p>FACILITY: _____</p> <p>HELICOPTER S/N: _____</p> <p>REGISTRY NO.: _____</p> <p>TOTAL TIME: _____</p> <p>SIGNATURE: _____</p> <p style="text-align: center;">NOTE</p> <p>Accomplish each 100 hours or 12 months inspection of intermediate gearbox operation, whichever occurs first.</p> <p><u>INTERMEDIATE GEARBOX</u></p> <ol style="list-style-type: none"> 1. Deleted 2. Deleted 3. Change oil in 212-040-003-007. <p style="text-align: center;">NOTE</p> <p>Oil change interval for gearbox 212-040-003-023 is every 300 hours or 12 months, whichever occurs first.</p>		



SPECIAL INSPECTIONS

5-29. EACH 100 HOURS/12 MONTHS OF TAIL ROTOR GEARBOX OPERATION

DATA REFERENCE	INSPECTION TASK DESCRIPTION	INITIAL	
		MECH	OTHER
Chapter 12	<p>DATE: _____ W.O. _____</p> <p>FACILITY: _____</p> <p>HELICOPTER S/N: _____</p> <p>REGISTRY NO.: _____</p> <p>TOTAL TIME: _____</p> <p>SIGNATURE: _____</p> <p style="text-align: center;">NOTE</p> <p style="text-align: center;">Accomplish each 100 hours or 12 months inspection of tail rotor gearbox operation, whichever occurs first.</p> <p><u>TAIL ROTOR GEARBOX</u></p> <ol style="list-style-type: none"> 1. Deleted 2. Deleted 3. Change oil in gearbox 212-040-004-005. <p style="text-align: center;">NOTE</p> <p style="text-align: center;">Oil change interval for gearbox 212-040-004-009 is every 300 hours or 12 months, whichever occurs first.</p>		



SPECIAL INSPECTIONS

5-29A. FIN SPAR CAP INSPECTION EVERY 100 HOURS

DATA REFERENCE	INSPECTION TASK DESCRIPTION	INITIAL	
		MECH	OTHER
ASB 212-20-162 Chapter 53 Chapter 65	DATE: _____ W.O. _____ FACILITY: _____ HELICOPTER S/N: _____ REGISTRY NO.: _____ TOTAL TIME: _____ SIGNATURE: _____		
	<p style="text-align: center;">NOTE</p> <p>Accomplish inspection of fin spar cap P/N 212-030-447-117 every 100 flight hours.</p> <p>This special inspection is applicable only if fin spar cap P/N 212-030-447-117 has been installed as original equipment or in accordance with TB 212-00-184.</p> <p><u>FIN SPAR CAP 212-030-447-117</u></p> <ol style="list-style-type: none"> 1. Remove the vertical fin driveshaft cover and 42° gearbox cover to gain access to the spar cap angle. 2. Clean exposed area of spar cap. 3. Inspect both flanges of the spar cap between fin station 50.00 and 71.00 for cracks, loose rivets and other damages using a 10X magnifying glass and a bright light (Figure 5-6B). 4. Inspect the exterior area of fin skin P/N 212-030-099-105 in contact with the spar cap for cracks, loose rivets and/or distortion. 5. If no damage is found, reinstall the 42° gearbox cover and vertical fin driveshaft cover. 6. Any discrepancies (cracks, debonding, or other damage) is found, report to Product Support Engineering before further flight. 		

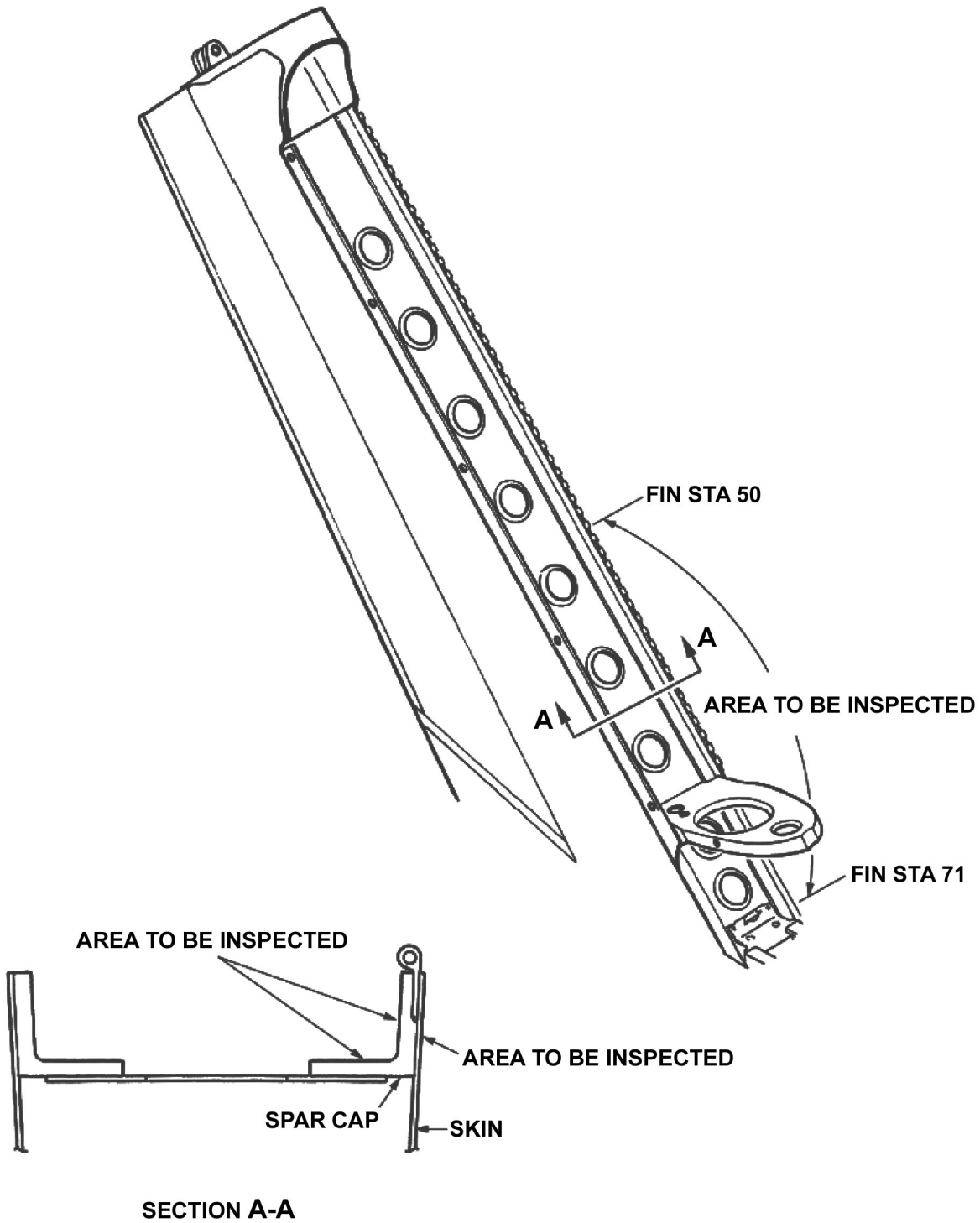

212_MM_05_0006b

Figure 5-6B. Spar Cap Inspection

SPECIAL INSPECTIONS

5-30. EACH 100 HOURS/12 MONTHS OF BATTERY SYSTEM OPERATION

DATA REFERENCE	INSPECTION TASK DESCRIPTION	INITIAL MECH OTHER	
<p>Chapter 96 and BHT-ALL-SPM</p>	<p>DATE: _____ W.O. _____</p> <p>FACILITY: _____</p> <p>HELICOPTER S/N: _____</p> <p>REGISTRY NO.: _____</p> <p>TOTAL TIME: _____</p> <p>SIGNATURE: _____</p> <p style="text-align: center;">NOTE</p> <p style="text-align: center;">Accomplish each 100 hours or 12 months inspection of battery system operation, whichever occurs first.</p> <p><u>BATTERY SYSTEM</u></p> <p>— Detailed Visual Inspection</p> <p>1. Service battery in accordance with the battery manufacturer's recommendations.</p> <p>— Operational Check</p> <p>1. Operationally check battery temperature sensor caution light system.</p>		

SPECIAL INSPECTIONS

5-31. 100 HOURS AFTER INSTALLATION OF TAILBOOM

DATA REFERENCE	INSPECTION TASK DESCRIPTION	INITIAL	
		MECH	OTHER
Chapter 53	<p>DATE: _____ W.O. _____</p> <p>FACILITY: _____</p> <p>HELICOPTER S/N: _____</p> <p>REGISTRY NO.: _____</p> <p>TOTAL TIME: _____</p> <p>SIGNATURE: _____</p> <p style="text-align: center;">NOTE</p> <p style="text-align: center;">Accomplish 100 hours inspection after each installation of tailboom.</p> <p><u>TAILBOOM</u></p> <p>— Torque</p> <p>Torque check tailboom attachment bolts.</p>		

SPECIAL INSPECTIONS

5-32. EACH 150 HOURS OF STARTER GENERATOR P/N 200SG119Q OPERATION

DATA REFERENCE	INSPECTION TASK DESCRIPTION	INITIAL	
		MECH	OTHER
<p>Chapter 71</p> <p>TM106 – Aircraft Parts Corp. Overhaul Instructions with Illustrated Parts Breakdown</p>	<p>DATE: _____ W.O. _____</p> <p>FACILITY: _____</p> <p>HELICOPTER S/N: _____</p> <p>REGISTRY NO.: _____</p> <p>TOTAL TIME: _____</p> <p>SIGNATURE: _____</p> <p style="text-align: center;">NOTE</p> <p>Accomplish each 150 hours of starter generator P/N 200SG119Q operation or more frequently if conditions warrant.</p> <p>P/N 200SG119Q refers to the starter generator without the QAD kit consisting of the mounting flange and ring clamp.</p> <p>This special inspection is not applicable to starter generator P/N 209-060-221-001.</p> <ol style="list-style-type: none"> 1. Remove starter generator P/N 200SG119Q. 2. Inspect starter generator brushes for wear. 3. If brushes are worn beyond allowable limits, refer to vendor manual and replace in accordance with manufacturer's instructions. 4. Install starter generator. 		

SPECIAL INSPECTIONS

5-33. FIN SPAR CAP INSPECTION EVERY 300 HOURS

DATA REFERENCE	INSPECTION TASK DESCRIPTION	INITIAL	
		MECH	OTHER
ASB 212-00-110	<p>DATE: _____ W.O. _____</p> <p>FACILITY: _____</p> <p>HELICOPTER S/N: _____</p> <p>REGISTRY NO.: _____</p> <p>TOTAL TIME: _____</p> <p>SIGNATURE: _____</p> <p style="text-align: center;">NOTE</p> <p>Accomplish inspection of fin spar caps P/N 212-030-125-001 and 212-030-447-101 every 300 flight hours.</p> <p>This special inspection is not required if fin spar cap P/N 212-030-125-001 has not been modified by retrofit kit 212-704-087 (ASB 212-01-73-1).</p> <p>This special inspection is not required if fin spar cap PN 212-030-447-117 has been installed as original equipment or in accordance with TB 212-00-184.</p> <p>Fin spar cap P/N 212-030-447-117 can be identified by the presence of decals that identify the cold-worked holes.</p> <p><u>FIN SPAR CAP 212-030-125-001 AND 212-030-447-101</u></p> <p>1. Carry out 300 hour recurring inspection in accordance with applicable section of ASB 212-00-110.</p> <p>2. Any discrepancies (cracks, corrosion, de-bonding, or other damage) are to be reported to Product Support Engineering before further flight.</p>		

SPECIAL INSPECTIONS

5-34. EACH 300 HOURS/12 MONTHS OF TRANSMISSION OPERATION

DATA REFERENCE	INSPECTION TASK DESCRIPTION	INITIAL MECH OTHER	
Chapter 63	<p>DATE: _____ W.O. _____</p> <p>FACILITY: _____</p> <p>HELICOPTER S/N: _____</p> <p>REGISTRY NO.: _____</p> <p>TOTAL TIME: _____</p> <p>SIGNATURE: _____</p> <p style="text-align: center;">NOTE</p> <p style="text-align: center;">Accomplish each 300 hours or 12 months inspection of transmission operation, whichever occurs first.</p> <p><u>TRANSMISSION</u></p> <p>— Detailed Visual Inspection</p> <ol style="list-style-type: none"> 1. Remove internal oil filter or internal full flow debris monitor as applicable (transmission 212-040-001-059, -131, -141, -191 and helicopters modified by TB 212-91-131). 2. Inspect internal oil filter or internal full flow debris monitor. If contamination, chips, or particles are found, determine and correct cause. <p>— Restoration</p> <ol style="list-style-type: none"> 1. Clean transmission internal oil filter or internal full flow debris monitor. 2. Service transmission oil system (Chapter 12) to proper level. <p>— Functional Check</p> <ol style="list-style-type: none"> 1. If installed, test internal full flow debris monitor chip detector electrical circuit. 		

SPECIAL INSPECTIONS

5-35. EACH 300 HOURS/3 MONTHS OF DRIVESHAFT OPERATION

DATA REFERENCE	INSPECTION TASK DESCRIPTION	INITIAL MECH OTHER	
<p>Chapter 12 Chapter 63 BHT-212-CR&O</p> <p>ASB 212-94-93</p>	<p>DATE: _____ W.O. _____</p> <p>FACILITY: _____</p> <p>HELICOPTER S/N: _____</p> <p>REGISTRY NO.: _____</p> <p>TOTAL TIME: _____</p> <p>SIGNATURE: _____</p> <p style="text-align: center;">NOTE</p> <p style="text-align: center;">Accomplish each 300 hours or 3 months of driveshaft operation, whichever occurs first.</p> <p><u>MAIN DRIVESHAFT 212-040-005-001 AND -011</u></p> <ol style="list-style-type: none"> 1. Remove main driveshaft assembly. 2. Visually inspect and lubricate. 3. Check date of manufacture of boot assembly (212-040-176-101). 		

SPECIAL INSPECTIONS

5-35A. EACH 300 HOURS/12 MONTHS INSPECTION OF TAIL ROTOR CONTROL TUBE AND BEARING

DATA REFERENCE	INSPECTION TASK DESCRIPTION	INITIAL	
		MECH	OTHER
ASB 212-15-154 Chapter 67	<p>DATE: _____ W.O. _____</p> <p>FACILITY: _____</p> <p>HELICOPTER S/N: _____</p> <p>REGISTRY NO.: _____</p> <p>TOTAL TIME: _____</p> <p>SIGNATURE: _____</p> <p style="text-align: center;">NOTE</p> <p style="text-align: center;">Accomplish each 300 flight hours or 12 months, whichever occurs first.</p> <p><u>TAIL ROTOR CONTROL TUBE 212-001-055-101 AND BEARING DAS4-14A1-512</u></p> <ol style="list-style-type: none"> 1. Gain access to the tail rotor control tube P/N 212-001-055-101 and bellcranks P/N 212-001-705-001 and P/N 212-001-759-101. 2. Disconnect both ends of the tail rotor control tube P/N 212-001-055-101 from the corresponding bellcranks. 3. Without removing the tail rotor control tube, visually inspect the flight control tube P/N 212-001-055-101 for cracks. If a crack is found, remove the tube from service. 4. Inspect both bearings P/N DAS4-14A1-512 for freedom of movement. Bearings shall be free to move in all directions and rotate freely. If a defective bearing is found, replace the defective bearing in accordance with the BHT-ALL-SPM. 5. Re-connect the tail rotor control tube in accordance with Chapter 67. 		

SPECIAL INSPECTIONS

5-36. MAIN ROTOR GRIP ULTRASONIC INSPECTION

DATA REFERENCE	INSPECTION TASK DESCRIPTION	INITIAL MECH OTHER	
	<p>DATE: _____ W.O. _____</p> <p>FACILITY: _____</p> <p>HELICOPTER S/N: _____</p> <p>REGISTRY NO.: _____</p> <p>TOTAL TIME: _____</p> <p>SIGNATURE: _____</p> <p style="text-align: center;">NOTE</p> <p>Main rotor grips P/N 204-011-121-009 with 15000 hours or more Time In Service (TIS) are to be ultrasonically inspected every 150 hours or 600 start/stop cycles, which ever occurs first.</p> <p>Main rotor grips P/N 204-011-121-009 with 4000 hours or more Time In Service (TIS) are to be ultrasonically inspected every 400 hours or 1600 start/stop cycles, which ever occurs first. Main rotor grips P/N 204-011-121-009 with less than 4000 hours TIS do not require inspection until reaching 4000 hours.</p> <p>Main rotor grips P/N 204-011-121-121 with 500 hours or more Time In Service (TIS) are to be ultrasonically inspected every 150 hours or 600 start/stop cycles, whichever occurs first. Main rotor grips P/N 204-011-121-121 with less than 500 hours TIS do not require inspection until reaching 500 hours.</p> <p>This inspection is not applicable to main rotor grips P/N 204-011-121-125.</p> <p>A start/stop cycle is defined as any time one or both of the helicopter engines are started followed by a shutdown.</p>		

SPECIAL INSPECTIONS

5-36. MAIN ROTOR GRIP ULTRASONIC INSPECTION (CONT)

DATA REFERENCE	INSPECTION TASK DESCRIPTION	INITIAL	
		MECH	OTHER
ASB 212-02-116 ASB 212-14-150 Chapter 62	<p><u>MAIN ROTOR GRIPS P/N 204-011-121-009 AND P/N 204-011-121-121</u></p> <ol style="list-style-type: none"> 1. Carry out ultrasonic inspection. 2. Any indication of a crack detected in accordance with the instructions will require the grip to be removed from service and a serviceable grip installed. If the grip was inspected by a level I special, the unserviceable grip is to be sent to a facility that has level II or III ultrasonic capability for further investigation. All grips that have a crack indication and have been inspected by a level II or III are to be sent to Bell Helicopter Textron. Refer to Information Letter IL GEN-04-98 for shipping instructions. 		

SPECIAL INSPECTIONS

5-37. EACH 500 HOURS/6 MONTHS OF BLADE SERVICE

DATA REFERENCE	INSPECTION TASK DESCRIPTION	INITIAL MECH OTHER	
Chapter 62	<p>DATE: _____ W.O. _____</p> <p>FACILITY: _____</p> <p>HELICOPTER S/N: _____</p> <p>REGISTRY NO.: _____</p> <p>TOTAL TIME: _____</p> <p>SIGNATURE: _____</p> <p style="text-align: center;">NOTE</p> <p>Accomplish each 500 hours or 6 months of blade inspection system (if installed), whichever occurs first.</p> <p><u>MAIN ROTOR BLADES</u></p> <p>Accomplish Blade Inspection System (BIS) check.</p>		

SPECIAL INSPECTIONS

5-38. EACH 600 HOURS OF TRANSMISSION OPERATION

DATA REFERENCE	INSPECTION TASK DESCRIPTION	INITIAL MECH OTHER	
	<p>DATE: _____ W.O. _____</p> <p>FACILITY: _____</p> <p>HELICOPTER S/N: _____</p> <p>REGISTRY NO.: _____</p> <p>TOTAL TIME: _____</p> <p>SIGNATURE: _____</p> <p style="text-align: center;">NOTE</p> <p>Accomplish each 600 hours inspection of transmission operation.</p> <p><u>TRANSMISSION ASSEMBLY 212-040-001-115, -119, -123, AND -127</u></p> <p>— Inspect</p> <p>1. Remove input pinion quill assembly and No. 2 hydraulic pump drive quill from transmission main case. Dimensionally inspect input pinion quill bore diameter of main case for out-of-round condition. Input quill bore shall be 6.7521 inches (171.5033 mm) and maximum out-of-round condition (maximum diameter — minimum diameter) shall be 0.0030 inch (0.0762 mm). Replace case assembly if bore diameter exceeds maximum conditions. Dimensionally inspect No. 2 hydraulic pump quill bore of main case assembly for out-of-round condition. Hydraulic drive quill bore maximum diameter shall be 5.0021 inches (127.05 mm) and maximum out-of-round condition shall be 0.0030 inch (0.0762 mm). Replace case assembly if bore diameter exceeds maximum conditions.</p>		

SPECIAL INSPECTIONS

5-38. EACH 600 HOURS OF TRANSMISSION OPERATION (CONT)

DATA REFERENCE	INSPECTION TASK DESCRIPTION	INITIAL	
		MECH	OTHER
BHT-212-CR&O	<p>2. Disassemble input pinion quill assembly sufficiently to ascertain whether triplex ball bearing outer races have rotated in sleeve. Note if etched V markings are still aligned. If bearing outer races have rotated, complete the disassembly of quill. Dimensionally inspect sleeve bore. If dimension is 5.51 inches (139.95 mm) or greater, replacement is required. Dimensionally inspect bearing outer diameter. If dimension is 5.51 inches (139.95 mm) or less, replacement is required.</p> <p>3. Inspect main input driven spiral bevel gear P/N 204-040-701-003 as follows:</p> <p style="padding-left: 40px;">a. Utilizing transmission case input quill port, inspect all 62 teeth of the main input driven spiral bevel gear convex side for unsatisfactory conditions such as scoring, hard lines, nicks, dents, chipping, metal deformation, etc.</p> <p style="text-align: center;">NOTE</p> <p style="padding-left: 40px;">Inspection mirrors and a suitable light are required. Turn rotor slowly to permit inspection of all gear teeth.</p> <p style="padding-left: 40px;">b. Inspect concave side of all 62 teeth. Refer to Figure 5-6 for unacceptable conditions on concave side.</p> <p style="padding-left: 40px;">c. Remove and replace any gear that does not meet inspection requirements.</p>		



SPECIAL INSPECTIONS

5-39. 600 HOURS/12 MONTHS OF TAIL ROTOR DRIVESHAFT COUPLING OPERATION

DATA REFERENCE	INSPECTION TASK DESCRIPTION	INITIAL MECH OTHER	
<p>BHT-212-CR&O Chapter 65</p>	<p>DATE: _____ W.O. _____</p> <p>FACILITY: _____</p> <p>HELICOPTER S/N: _____</p> <p>REGISTRY NO.: _____</p> <p>TOTAL TIME: _____</p> <p>SIGNATURE: _____</p> <p style="text-align: center;">NOTE</p> <p style="text-align: center;">Accomplish each 600 hours of component operation or 12 months, whichever occurs first. No Non-Destructive Inspection (NDI) required.</p> <p><u>TAIL ROTOR DRIVESHAFT COUPLINGS</u></p> <p>1. Remove tail rotor driveshaft assemblies.</p> <p style="text-align: center;">NOTE</p> <p style="text-align: center;">Disassemble flexible couplings only to the extent necessary to remove old grease and repack.</p> <p>2. Clean, visually inspect, and repack tail rotor hanger assembly flexible couplings.</p> <p>3. Clean, visually inspect, and repack intermediate gearbox flexible couplings.</p> <p>4. Clean, visually inspect, and repack tail rotor gearbox flexible coupling.</p> <p>5. Clean, visually inspect, and repack transmission tail rotor driveshaft flexible coupling.</p> <p>6. Install tail rotor driveshaft assemblies.</p>		

SPECIAL INSPECTIONS

5-40. 600 HOURS/12 MONTHS OF MAIN DRIVESHAFT OPERATION

DATA REFERENCE	INSPECTION TASK DESCRIPTION	INITIAL	
		MECH	OTHER
Chapter 63	<p>DATE: _____ W.O. _____</p> <p>FACILITY: _____</p> <p>HELICOPTER S/N: _____</p> <p>REGISTRY NO.: _____</p> <p>TOTAL TIME: _____</p> <p>SIGNATURE: _____</p> <p style="text-align: center;">NOTE</p> <p>Accomplish each 600 hours or 12 months of main driveshaft operation, whichever occurs first. No Non-Destructive Inspection (NDI) required.</p> <p style="text-align: center;"><u>MAIN DRIVESHAFT 212-040-005-003, -007, AND -103</u></p> <p>1. Remove main driveshaft.</p>		
	<p style="text-align: center;">NOTE</p> <p>Disassemble driveshaft only to the extent necessary to remove old grease and repack.</p> <p>2. Clean, visually inspect, and repack flexible couplings.</p> <p>3. Install main driveshaft.</p>		
BHT-212-CR&O			

SPECIAL INSPECTIONS

5-40A. EACH 600 HOURS/12 MONTHS INSPECTION OF MAGNETIC BRAKE ASSEMBLY

DATA REFERENCE	INSPECTION TASK DESCRIPTION	INITIAL MECH OTHER	
ASB 212-17-157	<p>DATE: _____ W.O. _____</p> <p>FACILITY: _____</p> <p>HELICOPTER S/N: _____</p> <p>REGISTRY NO.: _____</p> <p>TOTAL TIME: _____</p> <p>SIGNATURE: _____</p> <p style="text-align: center;">NOTE</p> <p>Accomplish the following inspection each 600 hours or 12 months, whichever occurs first.</p> <p>The following inspection is not required for helicopters equipped with IFR Kit P/N 212-706-106.</p> <p><u>MAGNETIC BRAKE ASSEMBLY P/N 204-001-376-003</u></p> <p>1. Perform a detailed visual inspection of the magnetic brake assembly in accordance with ASB 212-17-157.</p> <p>2. If the mechanical damage exceeds the limitation, contact Product Support Engineering.</p>		

SPECIAL INSPECTIONS

5-40B. EACH 600 HOURS/12 MONTHS INSPECTION OF FIRE EXTINGUISHER DISCHARGE TUBES

DATA REFERENCE	INSPECTION TASK DESCRIPTION	INITIAL	
		MECH	OTHER
ASB 212-12-146	<p>DATE: _____ W.O. _____</p> <p>FACILITY: _____</p> <p>HELICOPTER S/N: _____</p> <p>REGISTRY NO.: _____</p> <p>TOTAL TIME: _____</p> <p>SIGNATURE: _____</p> <p style="text-align: center;">NOTE</p> <p>Accomplish the following inspection each 600 hours or 12 months, whichever occurs first.</p> <p>The following inspection is not required if the discharge tubes 212-060-921-101 and 212-060-921-102 are installed in accordance with ASB 212-12-146.</p> <p><u>FIRE EXTINGUISHER DISCHARGE TUBES P/N 212-060-921-001FM AND -002FM</u></p> <p>1. Visually inspect the loop clamp AN735C16 installed on discharge tubes 212-060-921-001FM and 212-060-921-002FM for condition and security.</p>		

SPECIAL INSPECTIONS

5-41. EACH 1000 HOURS OF COMPONENT OPERATION

DATA REFERENCE	INSPECTION TASK DESCRIPTION	INITIAL	
		MECH	OTHER
	<p>DATE: _____ W.O. _____</p> <p>FACILITY: _____</p> <p>HELICOPTER S/N: _____</p> <p>REGISTRY NO.: _____</p> <p>TOTAL TIME: _____</p> <p>SIGNATURE: _____</p> <p style="text-align: center;">NOTE</p> <p style="text-align: center;">Accomplish each 1000 hours of component operation.</p>		
Chapter 29	<p><u>HYDRAULIC ACCUMULATORS</u></p> <p>1. Remove hydraulic accumulators.</p>		
BHT-212-CR&O	<p>2. Disassemble, clean, and visually inspect for corrosion and damage.</p> <p>3. Replace any unserviceable parts.</p> <p>4. Reassemble hydraulic accumulators.</p>		
Chapter 29	<p>5. Install hydraulic accumulators.</p>		
Chapter 79	<p><u>OIL COOLER BLOWERS</u></p> <p>1. Remove oil cooler blowers.</p>		
BHT-212-CR&O	<p>2. Disassemble, clean, and visually inspect for corrosion and damage.</p> <p>3. Replace bearings and any other unserviceable parts.</p> <p>4. Reassemble oil cooler blowers.</p>		





SPECIAL INSPECTIONS

5-41. EACH 1000 HOURS OF COMPONENT OPERATION (CONT)

DATA REFERENCE	INSPECTION TASK DESCRIPTION	INITIAL	
		MECH	OTHER
Chapter 79	5. Install oil cooler blowers.		

SPECIAL INSPECTIONS

5-42. FIRST 1000 HOURS OF COMPONENT TIME AND EACH 3000 HOURS THEREAFTER OF COMPONENT TIME

DATA REFERENCE	INSPECTION TASK DESCRIPTION	INITIAL	
		MECH	OTHER
ASB 212-76-6	<p>DATE: _____ W.O. _____</p> <p>FACILITY: _____</p> <p>HELICOPTER S/N: _____</p> <p>REGISTRY NO.: _____</p> <p>TOTAL TIME: _____</p> <p>SIGNATURE: _____</p> <p style="text-align: center;">NOTE</p> <p>Accomplish first 1000 hours inspection of component time and each 3000 hours thereafter of component time.</p> <p>Applicable to flight control tube assemblies: 204-001-957-001, 205-001-017-001/-007, 212-001-051-001, 212-001-060-001, and 212-076-151-001/-003/-005/-007/-009/-011. Supersedes ASB 212-76-6.</p> <p>Flight Control Tube Assemblies are identified by the following sub-assemblies:</p> <p>204-001-957-001 contains tube assembly 204-001-957-003 205-001-017-001 contains tube assembly 205-001-017-003 205-001-017-007 contains tube assembly 205-001-017-009 212-001-051-001 contains tube assembly 212-001-051-005 212-001-060-001 contains tube assembly 212-001-060-003 212-076-151-005 contains tube assembly 212-076-150-005 212-076-151-007 contains tube assembly 212-001-275-001 212-076-151-007 contains tube assembly 212-001-280-101  212-076-151-009 contains tube assembly 212-001-275-003 212-076-151-009 contains tube assembly 212-001-280-103  212-076-151-011 contains tube assembly 212-001-275-005 212-076-151-011 contains tube assembly 212-001-280-105 </p> <p> Control tube assemblies 212-001-280-101/-103/-105 are fabricated from corrosion Resistant Steel (CRES), special inspection not applicable.</p>		

SPECIAL INSPECTIONS

5-42. FIRST 1000 HOURS OF COMPONENT TIME AND EACH 3000 HOURS THEREAFTER OF COMPONENT TIME (CONT)

DATA REFERENCE	INSPECTION TASK DESCRIPTION	INITIAL	
		MECH	OTHER
BHT-212-CR&O	<p>1. Inspect flight control tube assemblies P/N 212-076-151-001/-003/-005/-007/-009/-011 as follows:</p> <ul style="list-style-type: none"> a. Measure and record overall length of control tube, and then remove adjustable clevis. b. Inspect control tube for internal corrosion using a borescope or equivalent. (Paint removal is not necessary.) Particular attention shall be given to threaded areas. Any paint anomalies such as blistering or discoloration will require paint removal and further inspection. Any sighted internal corrosion is cause for control tube rejection. If serviceable, refinish internal surface of control tube with two coats of lacquer (C-226) using fill and drain method. c. Visually inspect external surfaces of control tubes for mechanical damage and/or corrosion. Refer to the BHT-212-CR&O manual for limits. d. If serviceable, coat the control tube threaded area with corrosion preventive compound (C-101), reinstall clevis into control tube and adjust to recorded length. <p>2. Inspect P/N 204-001-957-001, 205-001-017-001 and -007, 212-001-051-001, 212-001-060-001 control tubes as follows:</p> <ul style="list-style-type: none"> a. Using a suitable container filled with 135 to 155°F (57 to 68°C) water, fully immerse the control tube for 2 minutes. b. Any air bubbles detected from the control tube as a result of the water immersion is cause for rejection of the tube. c. Provided no air bubbles are detected, the control tube may be considered serviceable. <p>3. Install flight control tubes and check rigging.</p>		

SPECIAL INSPECTIONS

5-42. FIRST 1000 HOURS OF COMPONENT TIME AND EACH 3000 HOURS THEREAFTER OF COMPONENT TIME (CONT)

DATA REFERENCE	INSPECTION TASK DESCRIPTION	INITIAL	
		MECH	OTHER
Chapter 67	<u>ELEVATORS</u>		
	— Inspect		
BHT-212-CR&O	1. Remove and Inspect elevators as follows:		
	a. Remove both elevators and inspect condition of ears on elevator horn 205-001-914 and mating ears on elevator attach fitting 205-030-475. Inspect ears by dye penetrant method. Replace horn or fitting if any cracks are evident.		
BHT-212-CR&O	b. Inspect elevators for general condition, cracks, and corrosion. Repair inboard rib if any cracks exist. The inboard rib shall be replaced if any cracks extend into rib flange.		

SPECIAL INSPECTIONS

5-43. EACH 1000 HOURS/12 MONTHS OF MAIN ROTOR BLADE OPERATION

DATA REFERENCE	INSPECTION TASK DESCRIPTION	INITIAL MECH OTHER	
<p>Chapter 62</p> <p>BHT-212-CR&O</p>	<p>DATE: _____ W.O. _____</p> <p>FACILITY: _____</p> <p>HELICOPTER S/N: _____</p> <p>REGISTRY NO.: _____</p> <p>TOTAL TIME: _____</p> <p>SIGNATURE: _____</p> <p style="text-align: center;">NOTE</p> <p style="text-align: center;">Accomplish each 1000 hours or 12 months of main rotor blade operation, whichever occurs first.</p> <p><u>MAIN ROTOR BLADES</u></p> <p>— Clean and Inspect</p> <p>1. Clean blade from an area starting at butt end of blade to several inches outboard of doublers on both upper and lower surfaces, using aliphatic naphtha (C-305) or equivalent.</p> <p style="text-align: center;">NOTE</p> <p style="text-align: center;">Inspection may be accomplished with blades installed on main rotor hub assembly.</p> <p>2. Inspect main rotor blade grip pads, grip plates, doublers, drag plates, and adjacent surfaces for voids, edge voids, corrosion, cracks, and condition of adhesive squeeze-out along bond lines. Refer to BHT-212-CR&O manual for inspection criteria and repair limits.</p>		



SPECIAL INSPECTIONS

5-44. EACH 1200 HOURS/24 MONTHS OF COMPONENT OPERATION

DATA REFERENCE	INSPECTION TASK DESCRIPTION	INITIAL MECH OTHER	
ASB 212-02-117 ASB 212-10-142 BHT-212-CR&O	<p>DATE: _____ W.O. _____</p> <p>FACILITY: _____</p> <p>HELICOPTER S/N: _____</p> <p>REGISTRY NO.: _____</p> <p>TOTAL TIME: _____</p> <p>SIGNATURE: _____</p> <p style="text-align: center;">NOTE</p> <p style="text-align: center;">Accomplish each 1200 hours or 24 months of listed component operation, whichever occurs first.</p> <p><u>MAIN ROTOR HUB PINS 204-012-104-003/-005 AND INBOARD STRAP FITTINGS 212-010-103-005/-007/-105</u></p> <ol style="list-style-type: none"> 1. Remove the four pins and two inboard strap fittings from the main rotor hub assembly. <ol style="list-style-type: none"> 1A. Do a detailed visual inspection of all the surfaces of the strap pin for mechanical or corrosion damage with a 10X magnifying glass. 1B. If mechanical damage or corrosion pitting is found on a strap pin, discard the pin. 2. Inspect pins and inboard strap fittings by magnetic particle method. 3. Magnetic particle indication interpreted as cracks are not acceptable and the pin or inboard strap fitting must be discarded. 4. If strap pins are found cracked, the mating strap fitting must also be discarded. 		



SPECIAL INSPECTIONS

5-44. EACH 1200 HOURS/24 MONTHS OF COMPONENT OPERATION (CONT)

DATA REFERENCE	INSPECTION TASK DESCRIPTION	INITIAL	
		MECH	OTHER
BHT 212-CR&O ASB 212-94-94	<p>5. If the pins are replaced (e.g., time expired), the mating fittings will be considered serviceable only after NDI inspection of the removed pins has confirmed they are not cracked.</p> <p>6. Reassemble main rotor hub assembly.</p> <p>7. Make an entry in the helicopter Historical Records (HR) to show that the main rotor hub pins and inboard strap fittings have been inspected in accordance with this special inspection.</p> <p><u>MAIN ROTOR YOKE 212-011-102-ALL</u></p> <p>— Detailed Visual Inspection</p> <p>1. Remove bearing races and spacers.</p>		
ASB 212-90-59	<p style="text-align: center;">NOTE</p> <p style="text-align: center;">Shield 204-012-116-107 does not need to be removed to accomplish the inspection procedure.</p> <p>2. Inspect yoke spindle for cracks and corrosion pits.</p> <p>3. Inspect yoke spindle bearing journals for wear.</p> <p>4. Any crack or wear beyond limits is cause for rejection of the yoke. Remove any corrosion.</p> <p>5. Assemble yoke.</p> <p><u>MAIN ROTOR DRAG BRACE 204-011-140-ALL</u></p> <p>— Inspect</p>		
BHT-212-CR&O	<p>1. Remove drag brace assemblies.</p> <p>2. Inspect drag brace assemblies for corrosion and mechanical damage.</p>		
BHT-ALL-SPM	<p>3. Perform a magnetic particle inspection.</p> <p>4. Install drag brace assemblies.</p>		





SPECIAL INSPECTIONS

5-44. EACH 1200 HOURS/24 MONTHS OF COMPONENT OPERATION (CONT)

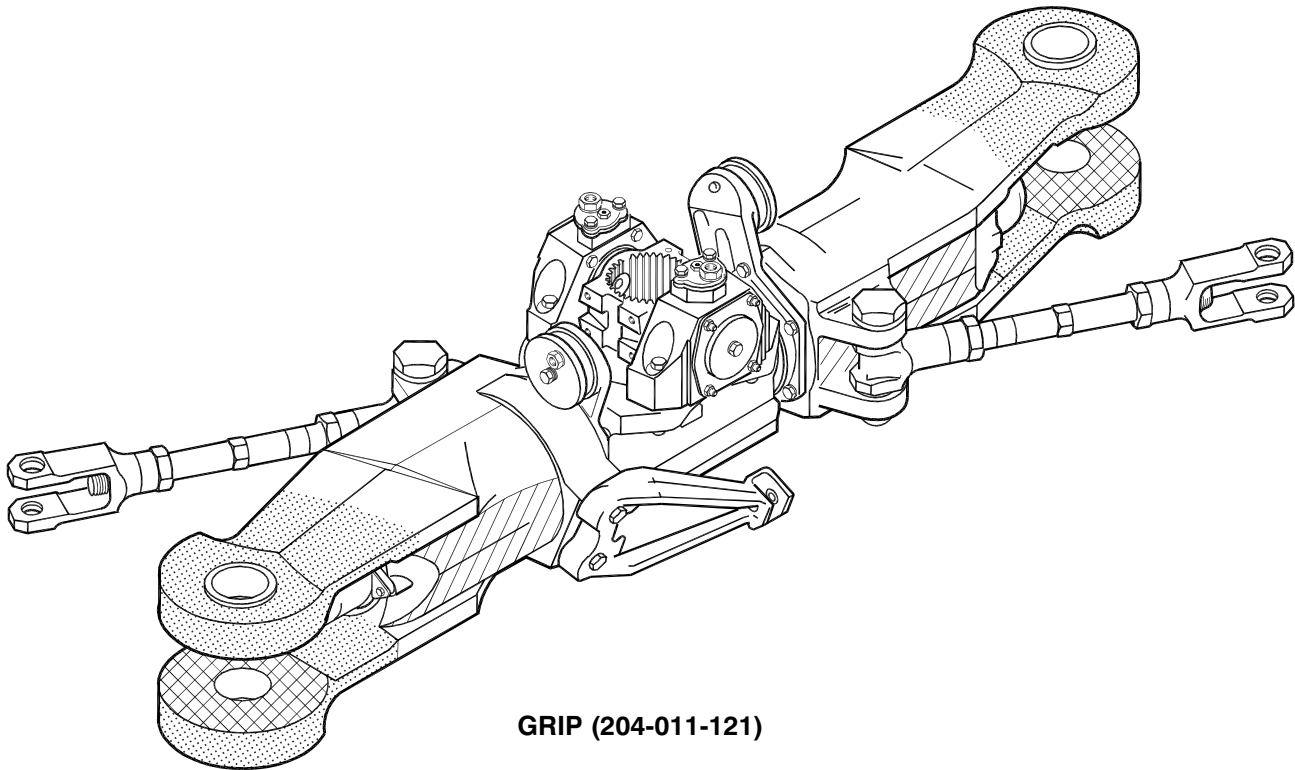
DATA REFERENCE	INSPECTION TASK DESCRIPTION	INITIAL	
		MECH	OTHER
BHT-212-CR&O	<p><u>MAIN ROTOR HUB GRIP 204-011-121-ALL</u></p> <p>— Detailed Visual Inspection</p> <ol style="list-style-type: none"> 1. Prepare both main rotor grip tangs for inspection by cleaning exposed surfaces with denatured alcohol (C-326) as per BHT-ALL-SPM. Wipe dry. 2. Inspect grip surfaces for evidence of hairline cracks on upper and lower tangs exposed surfaces. Pay particular attention to the lower tang lower surface from the blade bolt bushing flange to the trailing and leading edge of the tang. Crack indication requires the grip to be removed from service for further evaluation (Figure 5-7). 3. For main rotor grip 204-011-121-009, inspect grip barrels both leading and trailing sides for evidence of hairline cracks (Figure 5-7). 4. Check for gap (360°) between flange of blade bolt bushing and surface of grip tang. Maximum gap of 0.0025 inch (0.0635 mm) permitted. Noted gap greater than the maximum permitted requires bushing to be replaced. 5. Fit a blade bolt through both bushings simultaneously, bolt should be able to be turned with the fingers. If this cannot be accomplished, refer to BHT-212-CR&O, Chapter 62 for further inspection requirements. 6. Inspect buffer pads on tang inner surfaces for delamination. Any delamination will require buffer pad replacement (Figure 5-7). 		



GRIP (204-011-121)

-  **INSPECT BUFFER PAD FOR DELAMINATION (IF INSTALLED)**
-  **AREA TO BE INSPECTED UPPER AND LOWER TANGS ALL EXPOSED SURFACES**
-  **AREA TO BE INSPECTED GRIP BARREL LEADING AND TRAILING SIDES EXPOSED SURFACE (-009 GRIP ONLY)**

212_MM_05_0007

Figure 5-7. Inspection of Main Rotor Hub Grip (1200 Hours/24 Months)

SPECIAL INSPECTIONS

5-45. EACH 1200 HOURS OF MAIN ROTOR HUB PIN OPERATION — DELETED

DATA REFERENCE	INSPECTION TASK DESCRIPTION	INITIAL	
		MECH	OTHER
	<p style="text-align: center;">NOTE</p> <p>The Each 1200 Hours of Main Rotor Hub Pin Operation special inspection has been moved to the 1200 Hour/24 Months of Component Operation special inspection.</p>		

SPECIAL INSPECTIONS

5-45A. EVERY 12 MONTHS/2500 LANDINGS HIGH FORWARD CROSSTUBE DEFLECTION CHECK

DATA REFERENCE	INSPECTION TASK DESCRIPTION	INITIAL	
		MECH	OTHER
ASB 212-10-140	<p>DATE: _____ W.O. _____</p> <p>FACILITY: _____</p> <p>HELICOPTER S/N: _____</p> <p>REGISTRY NO.: _____</p> <p>TOTAL TIME: _____</p> <p>SIGNATURE: _____</p> <p style="text-align: center;">NOTE</p> <p>Accomplish the deflection check of the High Forward Crosstubes assemblies 205-050-403-031 and 412-050-046-101 at every 12 months or 2500 landings, whichever occurs first.</p> <p><u>HIGH FORWARD CROSSTUBES 205-050-403-031 AND 412-050-046-101</u></p> <p>1. Carry out the deflection check of the High Forward Crosstubes in accordance with ASB 212-10-140.</p>		

SPECIAL INSPECTIONS

5-45B. EVERY 12 MONTHS/5000 LANDINGS HIGH FORWARD CROSSTUBE FLUORESCENT PENETRANT INSPECTION

DATA REFERENCE	INSPECTION TASK DESCRIPTION	INITIAL	
		MECH	OTHER
ASB 212-10-140	<p>DATE: _____ W.O. _____</p> <p>FACILITY: _____</p> <p>HELICOPTER S/N: _____</p> <p>REGISTRY NO.: _____</p> <p>TOTAL TIME: _____</p> <p>SIGNATURE: _____</p> <p style="text-align: center;">NOTE</p> <p>Accomplish the fluorescent penetrant inspection of the High Forward Crosstubes assemblies 205-050-403-031 and 412-050-046-101 at every 12 months or 5000 landings, whichever occurs first.</p> <p><u>HIGH FORWARD CROSSTUBES 205-050-403-031 AND 412-050-046-101</u></p> <p>1. Carry out the fluorescent penetrant inspection of the High Forward Crosstubes in accordance with ASB 212-10-140.</p>		

SPECIAL INSPECTIONS

5-46. EACH 24 MONTHS OF FLIGHT CONTROL SYSTEM BOLT OPERATION

DATA REFERENCE	INSPECTION TASK DESCRIPTION	INITIAL	
		MECH	OTHER
Chapter 67	<p>DATE: _____ W.O. _____</p> <p>FACILITY: _____</p> <p>HELICOPTER S/N: _____</p> <p>REGISTRY NO.: _____</p> <p>TOTAL TIME: _____</p> <p>SIGNATURE: _____</p> <p style="text-align: center;">NOTE</p> <p>Accomplish each 24 months of flight control system bolt operation.</p> <p style="text-align: center;"><u>FLIGHT CONTROL SYSTEM BOLTS</u></p> <p style="text-align: center;">NOTE</p> <p>Refer to Chapter 4 for retirement life of flight control system bolts.</p> <p>— Inspect</p> <p>1. Remove the following flight control bolts:</p> <p style="padding-left: 40px;">a. Two fixed swashplate to right and left cyclic boost tube bolts P/N 20-057-5-24D.</p> <p style="padding-left: 40px;">b. One collective lever to collective boost tube bolt P/N 20-057-5-24D.</p> <p style="padding-left: 40px;">c. Three boost tube universal bolts P/N 20-057-24D.</p> <p style="padding-left: 40px;">d. Three universal to hydraulic cylinder tube bolts P/N 20-057-5-24D.</p> <p style="padding-left: 40px;">e. Two mixing lever to scissors tubes bolts P/N 20-057-5-27D.</p>		



SPECIAL INSPECTIONS

5-46. EACH 24 MONTHS OF FLIGHT CONTROL SYSTEM BOLT OPERATION (CONT)

DATA REFERENCE	INSPECTION TASK DESCRIPTION	INITIAL	
		MECH	OTHER
	<p>f. Two scissors tube to scissors bolts P/N 20-057-5-27D.</p> <p>g. Two pitch link to universal tube bolts P/N 20-057-6-27D.</p> <p>h. Two drive link to rotating swashplate bolts P/N 20-057-5-30D.</p> <p>i. Two pitch horn to pitch link bolts P/N 20-057-6-31D.</p> <p>j. Two universal to mixing lever bolts P/N 20-057-6-34D.</p> <p>k. Four mixing lever 204-011-301, pivot bolts P/N 20-057-6S20D.</p> <p>l. Four 20-057-6S24D mixing lever 212-010-302, pivot bolts P/N 20-057-6S23D or 20-057-6S24D.</p> <p>m. Two scissors to drive link bolts P/N 20-057-8S69D.</p> <p>n. Two scissors 204-011-406, pivot bolts P/N 20-057-8S90D.</p> <p>o. Two stabilizer bar pivot bolts P/N 20-057-10S27D or 20-057-10S29D.</p> <p>p. Three hydraulic cylinder to lower support bolts P/N 212-001-304-003 or 212-001-323-001.</p> <p>q. Two scissors 212-010-407, pivot bolts P/N 212-010-411-005 or 212-010-411-003-001 (ASB 212-89-56).</p> <p>r. Two stabilizer bar damper tube to damper wing shaft bolts P/N AN174-15.</p> <p>s. Two stabilizer bar damper tube to stabilizer bar bolts P/N AN174-20.</p> <p>t. Two collective lever to swashplate support bolts P/N AN178-22A.</p> <p>u. Deleted</p> <p>v. Deleted</p>		



SPECIAL INSPECTIONS

5-46. EACH 24 MONTHS OF FLIGHT CONTROL SYSTEM BOLT OPERATION (CONT)

DATA REFERENCE	INSPECTION TASK DESCRIPTION	INITIAL	
		MECH	OTHER
Chapter 67	<ul style="list-style-type: none">2. Clean bolts with cloth dampened with MEK (C-309).3. Inspect bolts for thread damage, shank wear, and corrosion. Replace any bolt that has damaged threads, detectable shank wear, or exhibits corrosion pitting.4. Apply corrosion preventive compound (C-104) to shanks of bolts only and install bolts.5. After bolts have been installed and nuts torqued and safetied, coat head of bolt, nuts, and lockwire with corrosion preventive compound (C-101).		

SPECIAL INSPECTIONS

5-47. EACH 3000 HOURS OF COMPONENT OPERATION

DATA REFERENCE	INSPECTION TASK DESCRIPTION	INITIAL MECH OTHER	
BHT-212-CR&O	<p>DATE: _____ W.O. _____</p> <p>FACILITY: _____</p> <p>HELICOPTER S/N: _____</p> <p>REGISTRY NO.: _____</p> <p>TOTAL TIME: _____</p> <p>SIGNATURE: _____</p> <p style="text-align: center;">NOTE</p> <p>Accomplish each 3000 hours of listed component operation.</p> <p><u>MAIN ROTOR MAST 204-040-366-021 AND 212-540-002-105</u></p> <p style="text-align: center;">NOTE</p> <p>Mast assembly 204-040-366-021 (installed in transmission prior to 212-040-001-059/-141) with no top case chip detector, overhaul interval is 2500 hours.</p> <p>Remove mast assembly from transmission and inspect inner and outer diameters of mast for corrosion and mechanical damage.</p> <p><u>TRANSMISSIONS 212-040-001-059, -137 AND SUBSEQUENT AND 212-540-002-103</u></p> <p>— Disassembly</p> <p>1. Visually inspect outside of transmission for evidence of corrosion, damage, and any oil leaks before disassembling transmission.</p>		

SPECIAL INSPECTIONS

5-47. EACH 3000 HOURS OF COMPONENT OPERATION (CONT)

DATA REFERENCE	INSPECTION TASK DESCRIPTION	INITIAL MECH OTHER	
BHT-212-CR&O	<p style="text-align: center;">NOTE</p> <p>Parts exhibiting evidence of wear or physical damage shall be checked dimensionally. Refer to BHT-212-CR&O manual for wear and damage limits.</p> <p>2. Disassemble transmission to accomplish the following:</p> <p style="padding-left: 20px;">a. Remove B4430 chip detector from 212-040-059 top case. Clean chip detector using drycleaning solvent (C-304). Visually inspect chip detector for cut packings, burrs, bent tube, and foreign material.</p> <p style="padding-left: 20px;">b. Remove 212-040-059 top case. Inspect mast assembly mating surface, pilot diameter and ring gear mating surface, pilot diameter for fretting and wear.</p> <p style="padding-left: 20px;">c. Planetary component removal:</p> <p style="padding-left: 40px;">(1) Remove 204-040-360 upper planetary assembly and 204-040-117 adapter as an assembly.</p> <p style="padding-left: 40px;">(2) Remove M27426-1220C retaining ring and 204-040-117 adapter from 204-040-360 planetary assembly. Do not disassemble 204-040-360 planetary assembly.</p> <p style="padding-left: 40px;">(3) Remove 204-040-337 liner and 204-040-135 bearing as an assembly. Do not disassemble.</p> <p style="padding-left: 40px;">(4) Remove 205-040-231 ring gear assembly.</p> <p style="padding-left: 40px;">(5) Remove 205-040-230 upper sun gear, 204-040-378 deflector, and RR687L retaining ring as an assembly.</p> <p style="padding-left: 40px;">(6) Remove 204-040-784 lower planetary assembly.</p> <p style="padding-left: 40px;">(7) Remove 204-040-338 liner, 204-040-135 bearing, and 204-040-257 liner as an assembly. Do not disassemble.</p> <p style="padding-left: 40px;">(8) Remove 205-040-229 lower sun gear.</p>		

SPECIAL INSPECTIONS

5-47. EACH 3000 HOURS OF COMPONENT OPERATION (CONT)

DATA REFERENCE	INSPECTION TASK DESCRIPTION	INITIAL	
		MECH	OTHER
BHT-212-CR&O	<p>3. Planetary component inspection:</p> <p>a. Visually inspect all parts of planetary assembly for evidence of wear and/or damage.</p> <p>b. Visually inspect gear tooth contact patterns on eight pinion assemblies in upper planetary assembly. It is normal for ring gear meshing side of planet pinions to have a double wear pattern. Check bearings for smoothness and freedom from binding by rotating the eight pinion assemblies. Visually inspect all lockwire provisions.</p> <p>c. Visually inspect external and internal spline teeth of 204-040-117 adapter for excessive wear and general condition.</p> <p>d. Check planetary support liners and 204-040-135 bearings for smoothness and freedom of rotation.</p> <p>e. Visually inspect upper flange surface and upper pilot diameter and lower flange surface and lower pilot diameter of 205-040-231 ring gear for fretting and wear. Visually inspect upper and lower gear teeth contact patterns for evidence of pitting, scoring, wear, or damage.</p>		
BHT-212-CR&O	<p>f. Visually inspect upper sun gear teeth for wear, damage, and contact pattern.</p>		
BHT-212-CR&O	<p>g. Disassemble 204-040-784 lower planetary to remove 204-040-785 spider.</p>		
BHT-ALL-SPM	<p>(1) Magnetic particle inspect 204-040-785 spider.</p> <p>(2) Visually inspect 204-040-785 spider spline for evidence of wear (i.e., step, end loading, etc.).</p>		
BHT-212-CR&O	<p>(3) Visually inspect gear tooth contact patterns on four pinion assemblies in lower planetary assembly. It is normal for ring gear meshing side of planetary pinions to have a double wear pattern. Check bearings for smoothness and freedom from binding by rotating the four pinion assemblies. Visually inspect all lockwire provisions.</p>		
BHT-212-CR&O	<p>h. Visually inspect 205-040-229 lower sun gear teeth for wear, damage, and contact pattern.</p>		

SPECIAL INSPECTIONS

5-47. EACH 3000 HOURS OF COMPONENT OPERATION (CONT)

DATA REFERENCE	INSPECTION TASK DESCRIPTION	INITIAL	
		MECH	OTHER
BHT-212-CR&O	<p>4. Remove B4429 chip detector from 212-040-053 case. Clean chip detector as required using drycleaning solvent (C-304). Visually inspect chip detector for cut packings, burrs, bent tube, and foreign material.</p> <p>5. Remove and inspect 204-040-393 manifold assembly. Remove, clean, and inspect 204-040-388 jet No. 7 for cut packing, burrs, and foreign material.</p> <p>6. Remove 204-040-362 quill assembly from 212-040-053 main case. Do not disassemble. Visually inspect mating flanges and pilot diameters for evidence of corrosion, fretting, and wear. Visually inspect all lockwire provisions. Check duplex bearing for smoothness and freedom of rotation by manually turning 204-040-701 gear. Visually check index marks on 204-040-701 gear and inner race of 205-040-245 bearing set for alignment.</p> <p style="text-align: center;">NOTE</p> <p>If index marks indicate movement between gear and inner race of bearing set, remove 204-040-701 gear, 204-040-357 plate, 204-040-348 shim, 205-040-245 bearing set, and 204-040-350 shim. Visually inspect inside diameter of 205-040-245 bearing set for signs of spinning. Visually inspect 205-040-245 bearing journal on 204-040-701 gear for sign of fretting. Inspect detail components to determine cause for inner race rotation.</p> <p>7. Using a torque wrench, check each of the 32 bevel gear retaining bolts 214-040-117-005, for minimum torque of 300 inch-pounds (33.895 Nm).</p> <p style="text-align: center;">NOTE</p> <p>Torque check is accomplished with increasing torque, not break away or loosening torque.</p> <p>a. If torque value of any one retaining bolt is less than 300 inch-pounds (33.895 Nm), remove bevel gear and inspect mating surfaces of gear 204-040-701, and shaft 204-040-324, for fretting damage.</p>		

SPECIAL INSPECTIONS

5-47. EACH 3000 HOURS OF COMPONENT OPERATION (CONT)

DATA REFERENCE	INSPECTION TASK DESCRIPTION	INITIAL	
		MECH	OTHER
BHT-212-CR&O	<p>b. The maximum acceptable depth of pitting is 0.0005 inch (0.0127 mm). Pitting is acceptable only in area on gear or shaft surface outside of diameter of bolt holes and is not acceptable within 0.100 inch (2.54 mm) of the edge of a bolt hole. Damage in excess of these limits is cause for rejection of part.</p> <p>c. Visually examine 204-040-701 gear teeth for evidence of wear, scoring, pitting, and contact pattern.</p> <p>d. Visually inspect roller bearing race on lower end of shaft for evidence of skidding, scoring, pitting, or damage.</p> <p>e. Visually inspect splines on upper and lower end of shaft for damage and/or wear.</p> <p>8. Visually inspect 204-040-700 pinion teeth for excessive wear, scoring, pitting, and contact pattern. Visually inspect vibro-etched index marks on 204-040-700 pinion and 214-040-118 bearing set for alignment. Inspection may be accomplished with input quill installed by viewing pinion shaft and bearing inner race between teeth and main case.</p> <p style="text-align: center;">NOTE</p> <p>If index marks indicate rotational movement between pinion and inner race of bearing set, 212-040-263 quill shall be removed from main case. Disassemble quill to remove 212-040-700 pinion and 214-040-118 bearing set.</p> <p>a. Visually inspect pinion bearing journal for signs of fretting and bearing inner race spinning.</p> <p>b. Clean 214-040-097 sleeve in drycleaning solvent (C-304).</p> <p>c. Visually ensure oil holes in 214-040-097 sleeve are free of any foreign material.</p> <p>d. Inspect detail components to determine cause for inner race rotation.</p>		



SPECIAL INSPECTIONS

5-47. EACH 3000 HOURS OF COMPONENT OPERATION (CONT)

DATA REFERENCE	INSPECTION TASK DESCRIPTION	INITIAL	
		MECH	OTHER
BHT-212-CR&O	<p>9. Remove tail rotor drive quill 212-040-365-025, to gain access to accessory drive and sump gears. Visually inspect accessory case input quill gear 212-040-150-005, and tail rotor drive quill gear 212-040-151-009, for general condition and wear pattern.</p>		
BHT-212-CR&O	<p>10. Inspect components in case assembly 212-040-054:</p> <ul style="list-style-type: none"> a. Visually inspect mating flange and pilot diameter of support case at main case joint for evidence of corrosion, fretting, and/or wear. b. Remove lift link fitting. c. Visually inspect lift link fitting pads for evidence of fretting and wear. d. Visually inspect bearing rollers for evidence of damage. e. Remove screws and washers from transmission support case lateral mounts, top and bottom. f. Visually inspect screws for corrosion and thread damage. g. Visually inspect washers for corrosion and thread damage. h. Visually inspect installed busings for corrosion and/or pitting. i. Visually inspect transmission support case lateral mount surfaces and threaded holes for mechanical and corrosion damage. 		
BHT-212-CR&O	<p>11. Assemble transmission.</p>		

SPECIAL INSPECTIONS

5-48. 10,000 HOUR TOTAL AIRFRAME TIME AND EACH 300 HOURS/12 MONTHS MAIN BEAM CAP OPERATION

DATA REFERENCE	INSPECTION TASK DESCRIPTION	INITIAL MECH OTHER	
	<p>DATE: _____ W.O. _____</p> <p>FACILITY: _____</p> <p>HELICOPTER S/N: _____</p> <p>REGISTRY NO.: _____</p> <p>TOTAL TIME: _____</p> <p>SIGNATURE: _____</p> <p style="text-align: center;">NOTE</p> <p>Accomplish at 10,000 hours total airframe time and each 300 hours or 12 months, whichever occurs first, thereafter.</p> <p><u>MAIN BEAM CAP</u></p> <p>This inspection is not required after main beam cap 205-030-186-101 is installed.</p> <p>Inspect main beam cap 205-030-186-005 in accordance with TB 212-88-106.</p>		



SPECIAL INSPECTIONS

5-48A. 10 YEARS COLLECTIVE STICK TUBE INSPECTION

DATA REFERENCE	INSPECTION TASK DESCRIPTION	INITIAL	
		MECH	OTHER
Chapter 67 BHT-212-CR&O BHT-212-SI-4 BHT-212-SI-89 TB 212-87-98	DATE: _____ W.O. _____ FACILITY: _____ HELICOPTER S/N: _____ REGISTRY NO.: _____ TOTAL TIME: _____ SIGNATURE: _____		
	<p style="text-align: center;">NOTE</p> <p style="text-align: center;">Accomplish inspection of pilot collective stick tube (212-001-181-001) and copilot collective stick tube (212-001-170-001) once every 10 years.</p> <p><u>FLIGHT CONTROLS</u></p> <ol style="list-style-type: none"> 1. Disassemble pilot and copilot (if installed) collective stick(s) to the extent necessary to remove throttle twist grips. 2. Referring to Figure 5-8, visually inspect stick tube for cracks using a 3X magnifying glass and a bright light. Pay particular attention to the base of the throttle slots that form the twist grip stops. 3. If a crack is found, replace stick tube. 4. Reassemble pilot and copilot (if installed) collective stick(s). 5. Check throttle controls for proper operation. 6. Check collective controls for proper operation. 		

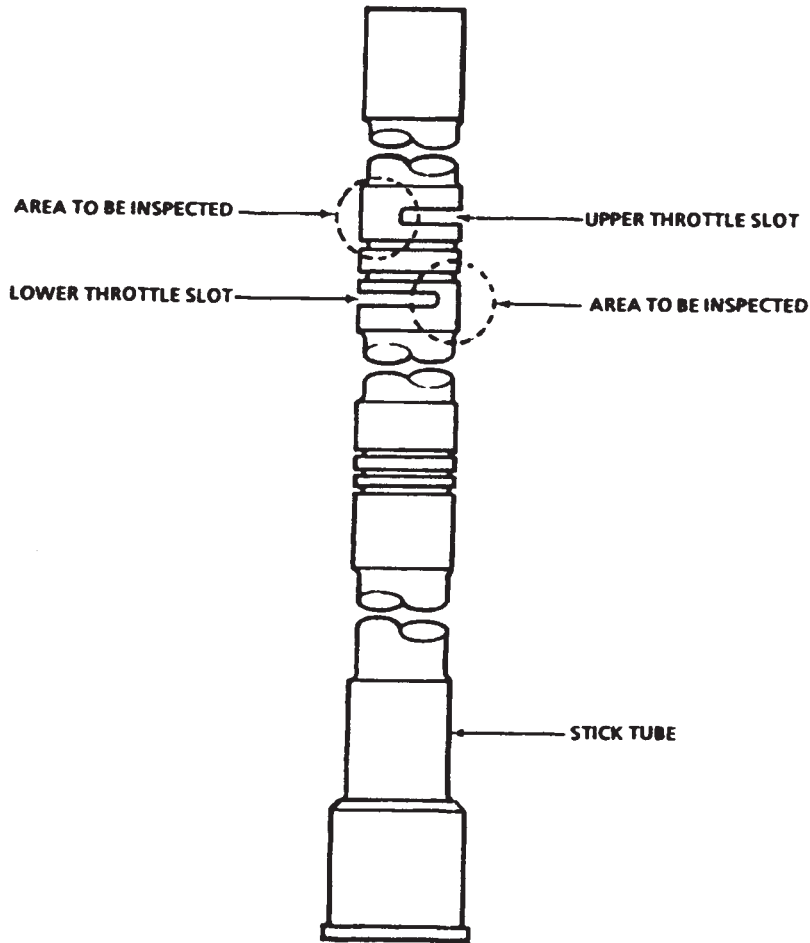

Figure 5-8. Collective Stick Tube

212_MM_05_0009

CONDITIONAL INSPECTIONS

5-49. CONDITION INSPECTION

1. Perform applicable conditional inspection of helicopter after hard landing, after blade strike or other rotating system torque spike, overspeed, overtorque, compressor stall or surge, lightning strikes, and after reduction (combining) gearbox clutch nonengagement, misengagement, or in-flight slippage ([paragraph 5-50](#) through [paragraph 5-56](#)).

2. If overhaul evaluation is specified, complete both the conditional inspection and normal inspection procedures (as applicable) for that component listed in BHT-212-CR&O manual.

3. If applicable conditional inspection does not provide complete information on a specific type of incident or if any doubt exists as to the serviceability of the helicopter or related components, contact:

Product Support Engineering

12800 rue de l'Avenir
Mirabel, Quebec J7J 1R4

Fax: (450) 433-0272

Tel: (450) 437-6201 or
800-363-8028 (U.S./Canada)

E-mail: psemedium@bh.com

CONDITIONAL INSPECTIONS

5-50. AFTER HARD LANDING

DATA REFERENCE	INSPECTION TASK DESCRIPTION	INITIAL MECH OTHER	
	<p>DATE: _____ W.O. _____</p> <p>FACILITY: _____</p> <p>HELICOPTER S/N: _____</p> <p>REGISTRY NO.: _____</p> <p>TOTAL TIME: _____</p> <p>SIGNATURE: _____</p> <p style="text-align: center;">NOTE</p> <p style="text-align: center;">Accomplish inspection after hard landing.</p> <p><u>AFTER HARD LANDING</u></p> <p style="text-align: center;">NOTE</p> <p>Evaluate components removed from a helicopter following a hard landing as an interrelated group. Make entries in component records of each removed component to cross reference part and serial numbers of other drive system components removed for evaluation.</p> <p>Hard landing is defined as any accident or incident in which ground impact of helicopter results in yielding or cracking of mounting lugs of transmission support case or noticeable yielding or cracking of fuselage pylon support structure, landing gear, or tailboom attachment structure. This definition is confined only to those accidents not involving sudden stoppage of main rotor or tail rotor.</p>		

CONDITIONAL INSPECTIONS

5-50. AFTER HARD LANDING (CONT)

DATA REFERENCE	INSPECTION TASK DESCRIPTION	INITIAL	
		MECH	OTHER
Chapter 32	<p>— Inspect</p> <p>1. If a hard landing is suspected, step a through step h shall be accomplished:</p> <p style="padding-left: 40px;">a. Inspect main and tail rotor blades for evidence of strike damage. If such evidence is found on either rotor, perform sudden stoppage — power on or off.</p> <p style="padding-left: 40px;">b. Visually inspect underside of fuselage and tailboom for evidence of ground contact.</p> <p style="padding-left: 40px;">c. Perform landing gear deflection check.</p> <p style="padding-left: 40px;">(1) If crosstubes have yielded, remove landing gear and inspect support and attaching structure for signs of yielding or other damage.</p> <p style="padding-left: 40px;">(2) If supports and attaching structure are not damaged, replace damaged landing gear components.</p> <p style="padding-left: 40px;">d. Inspect mast for evidence of hard rotor hub contact sufficient enough to yield or deform mast.</p> <p style="padding-left: 40px;">e. Inspect mast area around pylon mount for loose rivets or other damage.</p> <p style="padding-left: 40px;">f. Inspect tailboom and fuselage attachment for loose rivets, cracks, or other damage.</p> <p style="padding-left: 40px;">g. If no damage other than yielded landing gear crosstubes has been found at this point, it is reasonably certain a true hard landing did not occur. For helicopters on the Part A inspection program, complete a 100 hour /12 month inspection. For helicopters on the Part B inspection program, complete a 25 hour/15 day inspection and return helicopter to flight status provided no further evidence of damage is found.</p> <p style="padding-left: 40px;">h. If damage is more extensive than landing gear crosstube yielding, a hard landing has occurred. Comply with requirements of step 2 through step 4.</p>		

CONDITIONAL INSPECTIONS

5-50. AFTER HARD LANDING (CONT)

DATA REFERENCE	INSPECTION TASK DESCRIPTION	INITIAL MECH OTHER	
<p>ASB 212-96-100 and ASB 212-96-101</p>	<p>2. If a hard landing has occurred, the following steps shall be accomplished:</p> <p>a. Remove and perform an overhaul evaluation inspection of following components:</p> <p style="padding-left: 40px;">(1) Mast assembly</p> <p style="text-align: center;">NOTE</p> <p>If there is any yielding or deformation in area contacted by main rotor hub static stops or any other obvious damage, mast is unserviceable and non-repairable.</p> <p style="padding-left: 40px;">(2) Transmission</p> <p style="padding-left: 40px;">(3) Main driveshaft</p> <p>b. Perform a thorough visual inspection of following components that may be kept in service if no discrepancy or obvious damage is found. Replace any damaged component:</p> <p style="padding-left: 40px;">(1) Main rotor blades</p> <p style="padding-left: 40px;">(2) Main rotor hub</p> <p style="padding-left: 40px;">(3) Tail rotor blades</p> <p style="padding-left: 40px;">(4) Tail rotor hub</p> <p style="text-align: center;">NOTE</p> <p>Inspect trunnion assembly 212-010-738 or flapping stop 212-011-713 for yielding as noted in Chapter 64 to determine if tail rotor yoke assembly may have been exposed to bending.</p> <p style="padding-left: 40px;">(5) Tail rotor static stop</p> <p style="padding-left: 40px;">(6) Tail rotor yoke</p> <p style="padding-left: 40px;">(7) Intermediate gearbox</p>		

CONDITIONAL INSPECTIONS

5-50. AFTER HARD LANDING (CONT)

DATA REFERENCE	INSPECTION TASK DESCRIPTION	INITIAL MECH OTHER	
	<p>(8) Tail rotor gearbox</p> <p>(9) Tail rotor driveshafts</p> <p>(10) Tail rotor driveshaft hangers</p> <p>(11) Swashplate and support assembly</p> <p>(12) Scissors and sleeve assembly and collective levers</p> <p>(13) Stabilizer bar assembly</p> <p>(14) Helicopter structure directly supporting damaged components identified in previous inspections</p> <p>c. Check all cowling and doors for proper fit and alignment. Remove cowling and inspect all attachment fittings.</p> <p style="text-align: center;">NOTE</p> <p>If significant damage has been found in any area of airframe, inspection shall be expanded in those areas until it extends beyond zone of damage.</p> <p>d. Make a complete inspection, using a 10X magnifying glass, of pylon support structure for loose or sheared rivets, cracked brackets, buckled or cracked support angles and webs. Pay particular attention to pylon mounts attaching points.</p> <p>e. Make a complete inspection of lift link, lift link attachment fittings, and lift beam for cracks and other evidence of damage. Remove lift link and replace with like serviceable item, if damaged.</p> <p>f. Remove both pylon dampers, disassemble and check for internal yielding. Assemble dampers and install if no evidence of damage exists. Replace with like serviceable item if any damage is found.</p> <p>g. Install serviceable mast, transmission assembly, and main driveshaft assembly. Install removed pylon control components.</p>		

CONDITIONAL INSPECTIONS

5-50. AFTER HARD LANDING (CONT)

DATA REFERENCE	INSPECTION TASK DESCRIPTION	INITIAL	
		MECH	OTHER
Pratt & Whitney Canada PT6T-3/-3B Maintenance Manual	<p>h. Check all engine mount fittings and bolts for damage and looseness.</p> <p>i. Inspect engine firewalls for evidence of warping, crushing, or other damage.</p> <p>j. Make a complete inspection of area where tailboom is attached to forward fuselage section. This includes both sets of attachment fittings and longerons, beam caps, skins, webs, bulkhead flanges, and other structural members. Check torque on attachment bolts to determine if yielding has occurred.</p> <p>k. Completely inspect flight control system from pilot (and copilot) controls to rotor head for bent or damaged tubes, bellcranks, bellcrank supports, and for damaged control system bearings. Particular attention should be given to pylon controls, lower cylinder attachment support fitting, and adjacent airframe structure.</p> <p>l. Pressurize hydraulic systems and check for leaks, interference, binding, and satisfactory operation.</p> <p>m. Inspect fuel, oil, and pneumatic system for damage. Make engine ground run and visually check fuel, oil, and pneumatic lines for leaks.</p> <p>3. Inspect power plant in accordance with Pratt & Whitney Canada PT6T-3/-3B Maintenance Manual.</p> <p>4. If no significant damage has been found, no further inspection is necessary.</p>		

CONDITIONAL INSPECTIONS

5-51. AFTER BLADE STRIKE OR OTHER ROTATING SYSTEM TORQUE SPIKE

DATA REFERENCE	INSPECTION TASK DESCRIPTION	INITIAL MECH OTHER	
	<p>DATE: _____ W.O. _____</p> <p>FACILITY: _____</p> <p>HELICOPTER S/N: _____</p> <p>REGISTRY NO.: _____</p> <p>TOTAL TIME: _____</p> <p>SIGNATURE: _____</p> <p style="text-align: center;">NOTE</p> <p>To be accomplished after a main rotor blade or tail rotor blade strike or any drive system failure that inhibits free rotation of drive system.</p> <p><u>AFTER BLADE STRIKE OR OTHER ROTATING SYSTEM TORQUE SPIKE</u></p> <p style="text-align: center;">NOTE</p> <p>If the blade strike or rotating system torque spike is the result of crash damage or results in crash damage, all rotating system components shall be considered unserviceable and non-repairable.</p> <p>Crash damage is any damage sustained beyond the scope of that identified in the After Hard Landing conditional inspection (paragraph 5-50).</p>		

CONDITIONAL INSPECTIONS

5-51. AFTER BLADE STRIKE OR OTHER ROTATING SYSTEM TORQUE SPIKE (CONT)

DATA REFERENCE	INSPECTION TASK DESCRIPTION	INITIAL MECH OTHER	
	<p style="text-align: center;">NOTE</p> <p>Components removed from a helicopter for evaluation following a sudden stoppage shall be evaluated as an interrelated group. Removal records accompanying each component shall cross-reference part and serial numbers of other drive system components removed for evaluation.</p> <p>Sudden stoppage is defined as any rapid deceleration of drive system whether caused by seizure within helicopter transmission or by contact of main or tail rotor blades with the ground, water, snow, dense vegetation, trees, or other objects of sufficient density to cause rapid deceleration. Main or tail rotor blade damage, when caused by striking some object sufficient to require blade replacement (defined as removal for repair or scrap), is considered sudden stoppage. When sudden stoppage occurs, inspect helicopter and replace components as follows:</p> <p>1. Perform a sudden stoppage inspection as follows:</p> <p style="text-align: center;">NOTE</p> <p>If sudden stoppage inspection is the result of a tail rotor strike or main rotor blades striking the tail rotor driveshaft, comply with step g through step n.</p> <p>a. Main rotor blades.</p> <p>(1) Visually inspect both main rotor blades for evidence of damage. Check closely for wrinkled skin.</p> <p>(2) If any blade is damaged sufficiently to require blade repair, return both blades to an authorized overhaul facility. Make an entry in component record to show reason for removal was sudden stoppage.</p> <p>(3) If no evidence of damage is found on either blade, both blades may be retained in service.</p>		

CONDITIONAL INSPECTIONS

5-51. AFTER BLADE STRIKE OR OTHER ROTATING SYSTEM TORQUE SPIKE (CONT)

DATA REFERENCE	INSPECTION TASK DESCRIPTION	INITIAL	
		MECH	OTHER
BHT-212-CR&O	<p>b. Main rotor hub.</p> <p>(1) If main rotor blades were not damaged sufficiently to require blade replacement, hub may be retained in service.</p> <p>(2) If a main rotor blade is damaged sufficiently to require blade replacement, perform overhaul inspection on main rotor hub. If any doubt exists, contact Product Support Engineering.</p> <p>(3) If a main rotor blade is damaged beyond repair, scrap 204-011-121 grips and perform overhaul evaluation on main rotor hub. Make entry in component record to show reason for removal was sudden stoppage.</p>		
BHT-212-CR&O	<p>c. Pylon control components.</p> <p>(1) If one or more of the following discrepancies in step (a) through step (f) are found, swashplate assembly, stabilizer bar assembly, and scissors and sleeve assembly shall be removed and an overhaul evaluation performed.</p> <p>(a) Severe main rotor blade damage sufficient to require replacement.</p> <p>(b) Pitch horn failure.</p> <p>(c) Yielded stabilizer bar tube.</p> <p>(d) Control tube buckled or broken.</p> <p>(e) Transmission main support case mounting leg broken.</p> <p>(f) Damaged isolation mounts.</p> <p>If no condition exists as listed in preceding step (1), perform a close visual inspection. If no evidence of damage is found, the swashplate assembly, stabilizer bar assembly, and scissors and sleeve assembly may remain in service.</p> <p>d. Replace all bolts in rotating controls. Discard removed bolts.</p>		

CONDITIONAL INSPECTIONS

5-51. AFTER BLADE STRIKE OR OTHER ROTATING SYSTEM TORQUE SPIKE (CONT)

DATA REFERENCE	INSPECTION TASK DESCRIPTION	INITIAL	
		MECH	OTHER
BHT-212-CR&O	<p>e. Remove and inspect main driveshaft visually. If evidence of yielding or deformation is noted, scrap driveshaft assembly and attaching bolts. If no visual evidence of damage is detected, perform an overhaul evaluation. Make an entry in component record to show reason for removal and sudden stoppage.</p> <p>f. Transmission and mast assembly.</p> <p>(1) The following criteria are established to determine the need for removal and overhaul of the transmission and mast assembly. If any doubt exists contact Product Support Engineering.</p> <p>(a) Damage to the main rotor blades due to striking a foreign object requiring removal to repair or scrap blades.</p> <p>(b) Damage to the main rotor hub due to the main rotor blades striking a foreign object.</p> <p>(c) Damage or shearing of main rotor mast.</p> <p>(d) Seizure of drive system components.</p> <p style="text-align: center;">NOTE</p> <p>The transmission and mast assembly must be evaluated for serviceability as a set when removed for inspection requirements due to sudden stoppage. Inspect in accordance with the BHT-212-CR&O manual, ensuring both conditional and normal inspections are accomplished.</p>		
BHT-212-CR&O	<p style="text-align: center;">NOTE</p> <p>If mast has evidence of torsional yielding (defined as excessive runout, bending, deformation or spline misalignment), mast assembly (including mast bearing), transmission top case, transmission lower planetary spider, lower mast bearing, and pylon mounts shall be scrapped. The transmission shall be overhaul evaluated. If the main case is magnesium it shall be scrapped.</p>		

CONDITIONAL INSPECTIONS

5-51. AFTER BLADE STRIKE OR OTHER ROTATING SYSTEM TORQUE SPIKE (CONT)

DATA REFERENCE	INSPECTION TASK DESCRIPTION	INITIAL	
		MECH	OTHER
BHT-212-CR&O	<p>If mast assembly does not exhibit evidence of torsional yielding and transmission has no obvious damage that would render it non-repairable, perform an overhaul evaluation on both the transmission and mast assembly.</p> <p>If transmission is considered non-repairable as a result of sudden stoppage, the mast assembly shall be scrapped.</p> <p>If a main rotor blade is damaged beyond repair, main rotor mast assembly (204-011-450-ALL) shall be scrapped.</p> <p>In all cases, make an entry in component records to show reason for component removal was sudden stoppage.</p> <p>g. Tail rotor driveshaft hanger assemblies:</p> <p>(1) If a tail rotor driveshaft has been damaged beyond limits due to contact with a main rotor blade or other similar circumstance, the hanger assemblies to which the damaged shaft was attached shall be scrapped. If a tail rotor driveshaft fails as a result of torsional overload, all hanger assemblies and shafts shall be scrapped.</p> <p>(2) If inspection reveals no damage that would render hanger assemblies non-repairable, hanger assemblies shall have an overhaul evaluation performed. Make an entry in component record to show reason for removal is blade strike or torque spike.</p>		
Chapter 65	<p>h. Tail rotor driveshaft.</p> <p>(1) Remove tail rotor driveshafts and inspect for following conditions. If one or more of conditions listed in step (a) through step (e) are noted, all driveshafts and bearing hangers shall be considered unserviceable and non-repairable and shall be scrapped.</p> <p>(a) Curvic faces distorted.</p> <p>(b) Evidence of overload.</p>		

CONDITIONAL INSPECTIONS

5-51. AFTER BLADE STRIKE OR OTHER ROTATING SYSTEM TORQUE SPIKE (CONT)

DATA REFERENCE	INSPECTION TASK DESCRIPTION	INITIAL MECH OTHER	
	<p>(c) Cracks.</p> <p>(d) Loose or sheared rivets.</p> <p>(e) Scratches in excess of limits.</p> <p>(2) If inspection reveals no condition as previously listed in step (a) through step (e) exists, driveshaft may remain in service.</p> <p>i. Tail rotor hub and blade assembly.</p> <p style="text-align: center;">NOTE</p> <p>Nicks, scratches, or dents on top or bottom of blade (nonleading edge) that do not require removal of blades for replacement may not require the tail rotor assembly to be scrapped. If any doubt exists, contact Product Support Engineering.</p> <p>(1) Tail rotor hub and blade assembly: If sudden stoppage originated at tail rotor blades, tail rotor hub assembly shall be considered unserviceable and non-repairable and must be discarded.</p> <p>(a) If sudden stoppage originated at main rotor or main rotor transmission, tail rotor hub and blade assembly may remain in service provided there is no visible external damage. If visible damage is noted on tail rotor hub and blade assembly, an overhaul of the tail rotor hub shall be performed. Make an entry in component records to show reason for removal was sudden stoppage.</p> <p>(b) If sudden stoppage originated at tail rotor driveshaft, intermediate gearbox, or tail rotor gearbox remove tail rotor hub and blade assembly and perform an overhaul of the tail rotor hub. Make an entry in component record to show reason for removal was sudden stoppage.</p> <p>(c) If either tail rotor blade is damaged sufficiently to require blade repair, return both blades to an authorized overhaul facility. Make an entry in component record to show that reason for removal was sudden stoppage.</p>		

CONDITIONAL INSPECTIONS

5-51. AFTER BLADE STRIKE OR OTHER ROTATING SYSTEM TORQUE SPIKE (CONT)

DATA REFERENCE	INSPECTION TASK DESCRIPTION	INITIAL MECH OTHER	
BHT-212-CR&O	<p>(d) If no evidence of damage is found on either tail rotor blade, both blades may remain in service.</p> <p>(2) Tail rotor hubs with 212-011-702 yoke assembly and 212-011-713-103 flapping stop, reference ASB 212-96-101. Tail rotor hubs with 212-010-704-ALL yoke assembly or 212-010-744-ALL yoke assembly and 212-010-738-001 trunnion assembly, reference ASB 212-96-100.</p> <p>(a) Inspect 212-011-713 and 212-010-738 flapping stops for yielding, to determine if tail rotor yoke assembly may have been exposed to bending. A yielded flapping stop requires removal of the tail rotor yoke and flapping stop, and they shall be considered unserviceable and non-repairable, and must be discarded.</p> <p>j. Tail rotor rotating controls.</p> <p>(1) Perform a close visual inspection of the tail rotor rotating controls. If no evidence of damage is found, the tail rotor rotating control may remain in service. Replace all tail rotor rotating control bolts. If damage to the tail rotor rotating controls is found, perform an overhaul of the tail rotor rotating controls. Make an entry in component record to show that reason for removal was sudden stoppage.</p> <p>k. Tail rotor gearbox.</p> <p>(1) Remove tail rotor gearbox. Check for cracks, sheared or bent attaching studs, and evidence of case distortion. If any of these conditions are noted, gearbox is unserviceable and non-repairable and shall be scrapped.</p> <p>(2) If inspection reveals no condition as listed in previous step (1), perform an overhaul evaluation. Make an entry in component record to show reason for removal was sudden stoppage.</p> <p>l. Intermediate gearbox.</p> <p>(1) Remove intermediate gearbox. Check for cracks, case distortion, or broken lugs. If any of these conditions are noted, gearbox is unserviceable and non-repairable and shall be scrapped.</p>		

CONDITIONAL INSPECTIONS

5-51. AFTER BLADE STRIKE OR OTHER ROTATING SYSTEM TORQUE SPIKE (CONT)

DATA REFERENCE	INSPECTION TASK DESCRIPTION	INITIAL	
		MECH	OTHER
BHT-212-CR&O	<p>(2) If inspection reveals no condition as listed in previous step (1), perform an overhaul. Make an entry in component record to show reason for removal was sudden stoppage.</p> <p>m. Transmission sump case.</p> <p style="text-align: center;">NOTE</p> <p>If no evidence of damage was found in step g through step k, or step l, omit following step (1) through step (3).</p> <p>(1) If damage was found on bearing hangers, tail rotor driveshaft, intermediate gearbox, or tail rotor gearbox, remove tail rotor drive output quill from transmission sump case assembly.</p> <p>(2) Inspect output quill pinion for unusual load patterns on both sides of teeth. If no damage is found, reinstall quill. Transmission may be retained in service.</p>		
BHT-212-CR&O	<p>(3) If tail rotor quill reveals discrepancies, remove transmission and perform an overhaul evaluation. Make an entry in component record to show reason for removal was sudden stoppage.</p> <p>n. Reinstall or replace, as applicable, all removed components with serviceable components.</p>		
Pratt & Whitney Canada PT6T-3/-3B Maintenance Manual	<p>o. Inspect engine in accordance with Pratt & Whitney Canada PT6T-3/-3B Maintenance Manual.</p>		

CONDITIONAL INSPECTIONS

5-52. AFTER OVERSPEED

DATA REFERENCE	INSPECTION TASK DESCRIPTION	INITIAL MECH OTHER	
<p>Pratt & Whitney Canada PT6T-3/-3B Maintenance Manual</p>	<p>DATE: _____ W.O. _____</p> <p>FACILITY: _____</p> <p>HELICOPTER S/N: _____</p> <p>REGISTRY NO.: _____</p> <p>TOTAL TIME: _____</p> <p>SIGNATURE: _____</p> <p style="text-align: center;">NOTE</p> <p style="text-align: center;">Accomplish inspection after overspeed.</p> <p><u>AFTER OVERSPEED</u></p> <p style="text-align: center;">NOTE</p> <p>Components removed from a helicopter for evaluation following an overspeed shall be evaluated as an interrelated group. Removal records accompanying each component shall cross-reference part and serial numbers of other drive system components removed for evaluation.</p> <p>Overspeed is defined as any incident in which 110% main rotor RPM is exceeded.</p> <p>1. Perform overspeed inspection as follows:</p> <p style="padding-left: 40px;">a. Refer to Pratt & Whitney Canada PT6T-3/-3B Maintenance Manual for engine overspeed and inspection requirements.</p> <p style="padding-left: 40px;">b. Main rotor hub assembly.</p> <p style="padding-left: 80px;">(1) Remove main rotor hub. Remove main rotor blades.</p>		

CONDITIONAL INSPECTIONS

5-52. AFTER OVERSPEED (CONT)

DATA REFERENCE	INSPECTION TASK DESCRIPTION	INITIAL	
		MECH	OTHER
BHT-212-CR&O	<p>(2) Perform an overhaul conditional evaluation inspection. Make an entry in component record to show reason for removal was overspeed. Include amount of overspeed and duration, if known.</p>		
BHT-212-CR&O	<p>(3) Inspect main rotor blade retention bolts and drag brace bolts.</p> <p>c. Main rotor blades.</p> <p>(1) Inspect main rotor blades skin for wrinkles and deformation.</p> <p>(2) If no discrepancies are found in inspections outlined in step (1), main rotor blades may be retained in service.</p> <p>(3) If discrepancies are found in step (1), return both blades to an authorized blade repair station. Make an entry in component record to show reason for removal was overspeed. Include amount of overspeed and duration, if known.</p> <p>d. Tail rotor hub and blades.</p> <p>(1) Remove tail rotor hub and blade assembly.</p> <p>(2) Remove tail rotor blades.</p> <p>(3) Replace tail rotor blade retention bolts.</p> <p>e. Tail rotor blades.</p>		
BHT-212-CR&O	<p>(1) Perform major overspeed inspection of tail rotor blades. Make an entry in component record to show reason for removal was overspeed.</p> <p>f. Perform a close inspection of the following components. If no visual damage is found, components may be retained in service.</p> <p>(1) Main transmission.</p> <p>(2) Intermediate gearbox. Check gearbox for security and retaining bolts.</p>		

CONDITIONAL INSPECTIONS

5-52. AFTER OVERSPEED (CONT)

DATA REFERENCE	INSPECTION TASK DESCRIPTION	INITIAL MECH OTHER	
	<p>(3) Tail rotor gearbox. Check gearbox for security and retorque retaining nuts.</p> <p>(4) Main rotor mast.</p> <p>(5) Main input driveshaft.</p> <p>(6) Tail rotor driveshafts.</p> <p>(7) Tail rotor driveshaft hangers.</p> <p>(8) Stabilizer bar.</p> <p>(9) Swashplate.</p> <p>(10) Scissors and sleeve.</p> <p>(11) Tail rotor hub.</p> <p>g. Install a serviceable main rotor hub and blade assembly. Install serviceable tail rotor blades. Balance and install tail rotor hub and blade assembly.</p>		

CONDITIONAL INSPECTIONS

5-53. AFTER OVERTORQUE

DATA REFERENCE	INSPECTION TASK DESCRIPTION	INITIAL MECH OTHER	
<p>Pratt & Whitney Canada PT6T-3/-3B Maintenance Manual</p>	<p>DATE: _____ W.O. _____</p> <p>FACILITY: _____</p> <p>HELICOPTER S/N: _____</p> <p>REGISTRY NO.: _____</p> <p>TOTAL TIME: _____</p> <p>SIGNATURE: _____</p> <p style="text-align: center;">NOTE</p> <p style="text-align: center;">Accomplish inspection after overtorque.</p> <p><u>AFTER OVERTORQUE</u></p> <p style="text-align: center;">NOTE</p> <p>Components removed from a helicopter for evaluation following an overtorque shall be evaluated as an interrelated group. Removal records accompanying each component shall cross-reference part and serial numbers of other drive system components removed for evaluation.</p> <p>Overtorque is defined as any incident in which torsional loads are introduced into the helicopter dynamic system in excess of established limits.</p> <p>1. Refer to Pratt & Whitney Canada PT6T-3/-3B Maintenance Manual for engine overtorque inspection limits.</p> <p style="text-align: center;">NOTE</p> <p>To assist with determining engine overtorque inspection requirements, the following table provides a comparison between Bell Helicopter cockpit torque gauge % values and Pratt & Whitney Canada Maintenance Manual FT LB values.</p>		

CONDITIONAL INSPECTIONS

5-53. AFTER OVERTORQUE (CONT)

DATA REFERENCE	INSPECTION TASK DESCRIPTION	INITIAL MECH OTHER																								
	<table border="1" data-bbox="483 464 1094 835"> <thead> <tr> <th colspan="2">PT6T-3</th> <th colspan="2">PT6T-3B</th> </tr> <tr> <th>BELL % TORQUE</th> <th>P&WC FT LB</th> <th>BELL % TORQUE</th> <th>P&WC FT LB</th> </tr> </thead> <tbody> <tr> <td>87.6</td> <td>900</td> <td>89.1</td> <td>915</td> </tr> <tr> <td>83.6</td> <td>859</td> <td>85.2</td> <td>875</td> </tr> <tr> <td>77.8</td> <td>800</td> <td>79.4</td> <td>815</td> </tr> <tr> <td>71.8</td> <td>738</td> <td>71.8</td> <td>738</td> </tr> </tbody> </table> <p data-bbox="412 888 1162 1045">2. When overtorque has not exceeded 104% (108% for helicopters with TB 212-91-138 incorporated), perform thorough visual inspection of the following components. If inspection does not reveal any discrepancies or obvious damage to components, the components may be retained in service.</p> <ul style="list-style-type: none"> <li data-bbox="469 1081 704 1108">a. Tail rotor blades. <li data-bbox="469 1146 688 1173">b. Main rotor hub. <li data-bbox="469 1211 672 1239">c. Tail rotor hub. <li data-bbox="412 1276 1162 1339">d. Intermediate gearbox. Check gearbox for security and retorquer retaining bolts. <li data-bbox="412 1377 1162 1440">e. Tail rotor gearbox. Check gearbox for security and retorquer retaining nuts. <li data-bbox="469 1478 753 1505">f. Tail rotor driveshafts. <li data-bbox="469 1543 846 1570">g. Tail rotor driveshaft hangers. <li data-bbox="469 1608 789 1635">h. Stabilizer bar assembly. <li data-bbox="469 1673 656 1701">i. Swashplate. <li data-bbox="469 1738 870 1766">j. Scissors and sleeve assembly. <li data-bbox="469 1803 699 1831">k. Main driveshaft. 	PT6T-3		PT6T-3B		BELL % TORQUE	P&WC FT LB	BELL % TORQUE	P&WC FT LB	87.6	900	89.1	915	83.6	859	85.2	875	77.8	800	79.4	815	71.8	738	71.8	738	
PT6T-3		PT6T-3B																								
BELL % TORQUE	P&WC FT LB	BELL % TORQUE	P&WC FT LB																							
87.6	900	89.1	915																							
83.6	859	85.2	875																							
77.8	800	79.4	815																							
71.8	738	71.8	738																							

CONDITIONAL INSPECTIONS

5-53. AFTER OVERTORQUE (CONT)

DATA REFERENCE	INSPECTION TASK DESCRIPTION	INITIAL	
		MECH	OTHER
	<p>l. Mast.</p> <p>m. Transmission.</p> <p>3. When overtorque exceeds 104% (108% for helicopters with TB 212-91-138 incorporated), but does not exceed 112% perform the following:</p> <p>a. Perform thorough visual inspection of components listed in step 2.</p> <p>b. Inspect main transmission chip detector(s).</p> <p>c. Inspect main transmission internal filter or full flow debris monitor (as applicable).</p> <p>(1) If metal particles are found, indicating internal failure, remove transmission for overhaul evaluation. Make an entry in the component record explaining reason for removal was overtorque. Remove all transmission system oil lines. Flush and reinstall oil lines. Replace external oil filter element. Remove and scrap oil cooler. Install new oil cooler.</p> <p>(2) If chip detector(s) and internal filter or full flow debris monitor (as applicable) appear normal and there is no evidence of internal failure, return helicopter to service. Operate normally for 5 hours and then check chip detector(s) and internal filter or full flow debris monitor. If no metal particles are found indicating internal failure, normal scheduled inspection intervals may then be followed. If metal particles are present prior to or at the 5 hour check, or if there is any evidence of internal failure, remove transmission for overhaul evaluation. Make an entry in the component record explaining reason for removal was overtorque. Remove all transmission system oil lines. Flush and reinstall oil lines. Replace external oil filter element. Remove and scrap oil cooler. Install new oil cooler.</p> <p>d. Remove fifth mount bolts and remove fifth mount. Perform a thorough inspection of bolts and fifth mount support. Check for bent bolts and bent fifth mount support. Check for bolt hole alignment between transmission and fifth mount support.</p>		

CONDITIONAL INSPECTIONS

5-53. AFTER OVERTORQUE (CONT)

DATA REFERENCE	INSPECTION TASK DESCRIPTION	INITIAL MECH OTHER	
	<p>4. When overtorque has exceeded 112% perform the following:</p> <p style="padding-left: 40px;">a. Return the following components to an overhaul facility for overhaul evaluation.</p> <p style="text-align: center;">NOTE</p> <p>Component removal record of dynamic components shall reflect overtorque as reason for removal. Include amount of overtorque and duration, if known.</p> <p style="padding-left: 40px;">(1) Transmission.</p> <p style="padding-left: 40px;">(2) Main driveshaft.</p> <p style="padding-left: 40px;">(3) Main rotor hub.</p> <p style="padding-left: 40px;">(4) Mast.</p> <p style="padding-left: 40px;">(5) Perform thorough visual inspection of other components outlined in step 2.</p> <p style="padding-left: 40px;">b. Remove fifth mount bolts and remove fifth mount. Perform a thorough inspection of bolts and fifth mount support. Check for bent bolts and bent fifth mount support. Check for bolt hole alignment between transmission and fifth mount support.</p>		

CONDITIONAL INSPECTIONS

5-54. AFTER ENGINE COMPRESSOR STALL OR SURGE

DATA REFERENCE	INSPECTION TASK DESCRIPTION	INITIAL	
		MECH	OTHER
	<p>DATE: _____ W.O. _____</p> <p>FACILITY: _____</p> <p>HELICOPTER S/N: _____</p> <p>REGISTRY NO.: _____</p> <p>TOTAL TIME: _____</p> <p>SIGNATURE: _____</p> <p style="text-align: center;">NOTE</p> <p>Accomplish inspection after engine compressor stall or surge.</p> <p style="text-align: center;"><u>AFTER ENGINE COMPRESSOR STALL OR SURGE</u></p> <p style="text-align: center;">NOTE</p> <p>Discuss circumstances of reported compressor stall with pilot, if possible. Determine N₁ (GAS PROD) speed at which reported stall occurred. Check helicopter and engine logs for any pertinent history.</p> <p>Engine compressor stall or surge is characterized by a sharp rumble or a series of loud sharp reports, severe engine vibration and a rapid rise in Interturbine Temperature (ITT), depending on severity of surge. When a surge has been reported, progressively perform the following inspections as dictated by discrepant conditions.</p> <p>Components removed from a helicopter for evaluation following a compressor stall or surge shall be evaluated as an interrelated group. Removal records accompanying each component shall cross-reference part and serial numbers of other drive system components removed for evaluation.</p>		

CONDITIONAL INSPECTIONS

5-54. AFTER ENGINE COMPRESSOR STALL OR SURGE (CONT)

DATA REFERENCE	INSPECTION TASK DESCRIPTION	INITIAL	
		MECH	OTHER
<p>Pratt & Whitney Canada PT6T-3/-3B Maintenance Manual</p> <p>Pratt & Whitney Canada PT6T-3/-3B Maintenance Manual</p> <p>Pratt & Whitney Canada PT6T-3/-3B Maintenance Manual</p> <p>Pratt & Whitney Canada PT6T-3/-3B Maintenance Manual</p>	<p>1. Power plant.</p> <p>a. Examine inlet screen for blockage.</p> <p>b. Inspect engine compressor region for salt, dust, oil, or other contaminants. If contaminants are found, clean and perform a power check in accordance with Pratt & Whitney Canada PT6T-3/-3B Maintenance Manual.</p> <p>c. Inspect for visible Foreign Object Damage (FOD) to visible compressor blades.</p> <p>d. If compressor stall (surge) occurred during acceleration, refer to Pratt & Whitney Canada PT6T-3/-3B Maintenance Manual for inspection procedures.</p> <p>e. Perform test on pneumatic sense lines.</p> <p>f. If step a through step e do not reveal cause of surge, perform a hot end inspection in accordance with Pratt & Whitney Canada PT6T-3/-3B Maintenance Manual.</p> <p>2. Power train.</p> <p>a. If compressor stall occurs below 85% N1 (GAS PROD) speed, comply with step b and step c.</p> <p>b. Remove magnetic chip detectors from transmission, intermediate gearbox, and tail rotor gearbox. Inspect for metal particles.</p> <p>c. If no evidence of damage is found on tailboom pylon and no indication of metal particles are found on chip detectors, clean chip detectors and reinstall. Return helicopter to flight status and repeat chip detector inspection after 5 to 10 operating hours. If positive indication of damage is found on tailboom pylon or metal chips are found on chip detectors, during initial or 5 to 10 hour inspection, comply with the following step e through step i.</p> <p>d. If compressor stall occurs at 85% N₁ (GAS PROD) or above, comply with the following step e through step i.</p>		



CONDITIONAL INSPECTIONS

5-54. AFTER ENGINE COMPRESSOR STALL OR SURGE (CONT)

DATA REFERENCE	INSPECTION TASK DESCRIPTION	INITIAL	
		MECH	OTHER
Chapter 65	<p>e. Remove and inspect tail rotor driveshaft.</p> <p>f. Remove input and output drive quill from intermediate gearbox and inspect gear teeth on pinion and gear for damage with a 10X magnifying glass. If no evidence of scoring or scuffing is found, and there is no mechanical damage that would render gearbox unserviceable, reassemble and return to service. If gear teeth are scuffed or scored, or gearbox has sustained other damage, gearbox shall be replaced with a like, serviceable item and the following step g and step h accomplished.</p> <p>g. Remove tail rotor gearbox from helicopter and remove input quill. Inspect gear teeth on pinion and gear for damage with a 10X magnifying glass. If no evidence of scoring or scuffing is found, and there is no other damage that would render gearbox unserviceable, it may be reassembled and reinstalled for continued use. If gear teeth are scored or scuffed, or there is other damage that would render gearbox unserviceable, replace gearbox with a like, serviceable item.</p> <p>h. Remove tail rotor drive quill from transmission and inspect gear teeth for damage with a 10X magnifying glass. If there is no indication of scoring or scuffing, and there is no other damage that would render transmission unserviceable, it is suitable for continued use. If gear teeth are scored or scuffed, or there is other damage and that would render transmission unserviceable, replace transmission with a like, serviceable item and comply with step j.</p> <p>i. Install serviceable tail rotor driveshaft if transmission is not to be replaced.</p> <p>j. If transmission is to be replaced, the following components shall also be replaced (step (1) through step (3) and procedures outlines in step (4) through step (8) performed).</p> <p style="padding-left: 40px;">(1) Tail rotor bearing hanger assemblies.</p> <p style="padding-left: 40px;">(2) Tail rotor driveshafts.</p> <p style="padding-left: 40px;">(3) Tail rotor hub and blade assembly. Perform an overhaul. Make an entry in component record to show reason for removal was compressor stall.</p>		
BHT-212-CR&O			

CONDITIONAL INSPECTIONS

5-54. AFTER ENGINE COMPRESSOR STALL OR SURGE (CONT)

DATA REFERENCE	INSPECTION TASK DESCRIPTION	INITIAL	
		MECH	OTHER
BHT-212-CR&O	<p>(4) Remove inboard and outboard drag brace bolts. Check bolts for deformation and perform magnetic particle inspection. If satisfactory, return to service.</p> <p>(5) Visually inspect stabilizer bar outer tubes for bending. (Allowable deflection is 0.150 inch (3.81mm) in each tube.)</p> <p>(6) Remove main rotor pillow blocks from main rotor yoke and check for deformation of bushings and bushing holes in pillow blocks and yoke.</p> <p>(7) Perform close visual inspection of all other main rotor components.</p> <p>(8) If any discrepancies are noted as a result of inspection in step (4) through step (7), remove and replace main rotor hub and blade assembly, stabilizer bar assembly, and mast assembly. Removed assemblies shall have an overhaul evaluation performed. Make an entry in component records to show reason for removal was compressor stall.</p> <p>3. Airframe.</p> <p>a. Check tailboom fin for evidence of damaged skin panels and/or structure and rivets for looseness and/or sheared heads. If inspection shows no indication of damage, return helicopter to flight status. If positive evidence of damage is found, comply with step b through step e.</p> <p>b. Remove skin from tailboom fin adjacent to tail rotor gearbox mounting. Inspect all support structures in this area and repair as required. Install new skin.</p> <p>c. Make close visual inspection of complete tailboom structure for distortion, buckles, skin cracks, and sheared or loose rivets, paying particular attention to tailboom attachment points at FS 241.43 to 243.9 and adjacent fuselage to tailboom structure and intermediate gearbox support structure.</p> <p>d. Make close visual inspection of main pylon support and engine mount attachment structure for distortion, buckles, cracks, sheared, or loose rivets, etc.</p>		

CONDITIONAL INSPECTIONS

5-54. AFTER ENGINE COMPRESSOR STALL OR SURGE (CONT)

DATA REFERENCE	INSPECTION TASK DESCRIPTION	INITIAL	
		MECH	OTHER
	<p>e. If discrepancies found during inspection in step b through step d cannot be repaired by standard procedures, replace discrepant assembly.</p>		

CONDITIONAL INSPECTIONS

5-55. AFTER LIGHTNING STRIKES

DATA REFERENCE	INSPECTION TASK DESCRIPTION	INITIAL	
		MECH	OTHER
	<p>DATE: _____ W.O. _____</p> <p>FACILITY: _____</p> <p>HELICOPTER S/N: _____</p> <p>REGISTRY NO.: _____</p> <p>TOTAL TIME: _____</p> <p>SIGNATURE: _____</p> <p style="text-align: center;">NOTE</p> <p style="text-align: center;">Accomplish inspection after lightning strikes.</p> <p><u>AFTER LIGHTNING STRIKES</u></p> <p style="text-align: center;">NOTE</p> <p>In all instances in the following inspections, if significant damage has been found in any area, inspection shall be expanded in those areas until it extends beyond zone of damage. Any damage found anywhere on helicopter shall be recorded in detail and copies of these records shall be provided along with any component returned for overhaul to assist overhauling facility in evaluating component.</p> <p>When helicopter is suspected of receiving a lightning strike, the following precautions shall be followed:</p> <p>1. Visually inspect all external surfaces with particular attention to main rotor blades and hub, transmission and mast assembly, tail rotor blades and hub, tail rotor gearbox, and vertical fin. Check electrical instruments and systems. Verify magnetic compass accuracy.</p>		

CONDITIONAL INSPECTIONS

5-55. AFTER LIGHTNING STRIKES (CONT)

DATA REFERENCE	INSPECTION TASK DESCRIPTION	INITIAL	
		MECH	OTHER
BHT-212-CR&O	<p>2. If visual indications of damage are present, proceed as follows:</p> <p style="padding-left: 40px;">a. Remove main rotor blades and visually inspect. If blades show any of the following indications, scrap blades.</p> <p style="padding-left: 80px;">(1) Inspect blades for signs of burns. Burn marks can be very minute.</p> <p style="padding-left: 80px;">(2) Inspect blades for debond in all bonded areas.</p> <p style="padding-left: 40px;">b. Remove main rotor hub and forward to an overhaul facility for overhaul. Tag hub stating lightning strike as reason for removal. Inspect main rotor hub and rotating controls for indication of arcing or burning.</p> <p style="padding-left: 40px;">c. Remove main driveshaft for inspection.</p> <p style="padding-left: 80px;">(1) Disassemble to the same extent required for coupling. Repack and clean couplings.</p> <p style="padding-left: 80px;">(2) Visually inspect couplings for any evidence of arc burning or pitting. Pay special attention to tips, roots, and profiles of male and female coupling teeth. Any evidence of arc burning or pitting is cause for rejection.</p>		
BHT-212-CR&O	<p style="padding-left: 40px;">d. Remove tail rotor output coupling for inspection.</p> <p style="padding-left: 80px;">(1) Disassemble to same extent required for coupling. Repack and clean couplings.</p> <p style="padding-left: 80px;">(2) Visually inspect couplings for any evidence of arc burning or pitting. Pay special attention to the tips, roots, and profiles of male and female coupling teeth. Any evidence of arc burning or pitting is cause for rejection.</p>		

CONDITIONAL INSPECTIONS

5-55. AFTER LIGHTNING STRIKES (CONT)

DATA REFERENCE	INSPECTION TASK DESCRIPTION	INITIAL	
		MECH	OTHER
Chapter 63	<p>e. If main rotor blades, main rotor hub, main driveshafts, or tail rotor output coupling exhibit evidence of damage that can be attributed to a lightning strike, remove transmission and mast assembly for overhaul. Tag components stating lightning strike as reason for removal. If no evidence of damage is noted on above mentioned components, partially remove and inspect main transmission as follows:</p> <p>(1) Remove and inspect all transmission chip detectors.</p> <p>(2) If any evidence of arc burning or pitting is noted, or excessive debris is found, remove transmission and mast assembly for overhaul. Tag components stating lightning strike as reason for removal.</p>		
Chapter 63	<p>(3) If no evidence of arc burning or pitting is noted, ground run light on skids for 1 hour. Reinspect chip detectors and remove and inspect oil filter. Repeat these inspections after accumulating 5 flight hours but prior to 10 flight hours.</p>		
Chapter 65	<p>f. Inspect tail rotor blades and hub. Scrap blades if indications of burns or debonding are present. Remove tail rotor hub for overhaul. Tag hub stating lightning strike as reason for removal.</p> <p>g. Remove and inspect tail rotor gearbox chip detector and intermediate gearbox chip detector.</p> <p>h. If the tail rotor blades, tail rotor hub, or tail rotor output coupling exhibit evidence of damage, which can be attributed to a lightning strike, or excessive debris is found on chip detectors, remove tail rotor gearbox, intermediate gearbox and tail rotor driveshaft hangers for overhaul. Tag components stating lightning strike as reason for removal. Additionally, the tail rotor driveshaft tubes, disc pack couplings, and attaching hardware shall be visually inspected for evidence of arc burns or pitting. Any evidence of arc burns or pitting is cause for rejection.</p> <p>i. If no evidence of arc burns or pitting is noted, operate helicopter light on skids for 1 hour. Reinspect chip detector. Repeat this inspection after accumulating 5 flight hours but prior to 10 flight hours.</p>		

CONDITIONAL INSPECTIONS

5-55. AFTER LIGHTNING STRIKES (CONT)

DATA REFERENCE	INSPECTION TASK DESCRIPTION	INITIAL	
		MECH	OTHER
Chapter 63	<p>3. If no visual indications of damage are present, proceed as follows:</p> <p>a. Remove and inspect all transmission chip detectors.</p> <p>(1) If excessive debris is found on chip detectors, remove transmission and mast assembly for overhaul.</p> <p>(2) If little or no debris is found, operate helicopter light on skids for 1 hour. Reinspect chip detectors and remove and inspect oil filter. Repeat these inspections after accumulating 5 flight hours but prior to 10 flight hours.</p>		
Chapter 63 BHT-212-CR&O	<p>(1) Visually inspect bearings for signs of electrical arcing, burning, or delamination.</p> <p>(2) Visually inspect pitch change links at drive assembly connections for arcing burns.</p> <p>(3) If indications of arcing or burning are present, overhaul main rotor hub and drive assembly. Replace affected pitch change link, including attaching hardware.</p> <p>(4) If no indications are found, reassemble main rotor hub.</p>		
BHT-212-CR&O	<p>4. Prior to first flight after a suspected or confirmed lightning strike, verify proper function of all drive system component chip detectors as follows:</p> <p>a. Remove electrical connector from chip detector.</p> <p>b. Remove chip detector and reinstall connector.</p> <p>c. With helicopter electrical power on, bridge chip detector gap with a clean conductive object (screwdriver).</p> <p>d. Verify proper indication on the CHIP indicator panel and caution panel. Verify illumination of MASTER CAUTION light.</p> <p>e. Using a single strand of steel wool to bridge gap of one chip detector, verify proper function of chip burn off system.</p>		

CONDITIONAL INSPECTIONS

5-55. AFTER LIGHTNING STRIKES (CONT)

DATA REFERENCE	INSPECTION TASK DESCRIPTION	INITIAL MECH OTHER	
	<p>f. Make repairs as required.</p> <p>5. When established that lightning has struck helicopter, inspections of electrical and instrument systems that follow are mandatory to ensure safety of flight.</p> <p>a. Inspect all electrical wiring, bundles, and connectors for burning or electrical arcing. Unplug all connectors and inspect pins and housing for electrical arcing or burning. Inspect interior of all circuit breaker panels for burning or electrical arcing. Replace any wires, connectors, or circuit breakers found to be damaged.</p> <p>b. inspect main rotor blade and control links, transmission system, driveshafts, gearboxes, and tailboom structure for magnetization. Using a magnetometer with a range no larger than ± 5 gauss, place arrow or red dot (depending on magnetometer model) within 0.5 inch (12.7 mm) of item being checked, and point it directly at item. If any items or components have a reading greater than 1 gauss, those items shall be degaussed.</p> <p style="text-align: center;">NOTE</p> <p>Do not test chip detectors for magnetization. If transmission or gearbox magnetic readings are greater than 1 gauss near chip detector, remove chip detector from housing and repeat test.</p> <p>c. Remove and bench test voltage regulator(s). Operationally check DC generator, starter generator, and inverter(s) for proper operation. Visually inspect generator, starter generator, and inverter(s) for burns or electrical arcing. If damaged, remove for internal inspection and bench test.</p> <p>d. Perform operational check of bussing system.</p> <p>e. Inspect transmission and tail rotor gearbox chip detectors for proper operation. Remove chip detectors found inoperative.</p> <p>f. Perform operational check of interior and exterior lighting system. Replace lamps, bulbs, and lighting assemblies as required.</p>		

CONDITIONAL INSPECTIONS

5-55. AFTER LIGHTNING STRIKES (CONT)

DATA REFERENCE	INSPECTION TASK DESCRIPTION	INITIAL MECH OTHER	
Chapter 32	<p>g. Perform operational check on all instruments. Remove and repair/replace instruments and sensor found to be defective.</p> <p>h. Perform operational check on all caution messages for proper operation.</p> <p>6. When it has been established that lightning has struck the helicopter, the inspections of structure that follow are mandatory to ensure safety of flight:</p> <p style="text-align: center;">NOTE</p> <p>Arcing damage on metal components of airframe structure, when cleaned out to twice its visible depth, shall be treated as mechanical damage. Damage limits establish repairability and/or scrapping of component. Any other structural damage, tears, voids, rupture, etc., directly or indirectly related to lightning strike, shall also be treated as mechanical damage.</p> <p>a. Check sandwich panels in suspect areas for voids or debond. If damage is apparent, proceed with normal maintenance procedures.</p> <p>b. Check fixed controls and support system components for possible arcing damage. Bearings in rod ends, bellcranks, and supports should be most susceptible to arcing damage. Check bearings for smooth rotation. Visibly inspect attaching hardware of support for signs of lightning damage, damaged finish and/or burns. If damage is evident, remove supports and inspect mounting holes and mating surfaces for arcing damage. Arcing damages shall be blended out to twice its visible depth, and repaired damages shall not exceed mechanical damage limits.</p> <p>c. When apparent lightning has grounded through skid landing gear, remove entire landing gear assembly and inspect crosstubes and airframe support fittings for possible arcing damage. Specifically, inspect attaching holes and mating surfaces of the crosstubes directly beneath landing gear bearing/retaining supports. Clean out arcing damage to twice its visible depth. The damage, after cleanup, shall not exceed allowable mechanical damage limits.</p>		

CONDITIONAL INSPECTIONS

5-55. AFTER LIGHTNING STRIKES (CONT)

DATA REFERENCE	INSPECTION TASK DESCRIPTION	INITIAL MECH OTHER	
	<p>d. Any airframe metal parts not specifically identified above, but are suspect, shall be noted in maintenance log and shall be reinspected prior to next 100 hours of flight.</p>		

CONDITIONAL INSPECTIONS

5-56. AFTER ENGINE COMBINING GEARBOX CLUTCH NONENGAGEMENT, MISENGAGEMENT, OR IN-FLIGHT SLIPPAGE

DATA REFERENCE	INSPECTION TASK DESCRIPTION	INITIAL	
		MECH	OTHER
Pratt & Whitney Canada PT6T-3/-3B Maintenance Manual	<p>DATE: _____ W.O. _____</p> <p>FACILITY: _____</p> <p>HELICOPTER S/N: _____</p> <p>REGISTRY NO.: _____</p> <p>TOTAL TIME: _____</p> <p>SIGNATURE: _____</p> <p style="text-align: center;">NOTE</p> <p>Accomplish inspection after engine combining gearbox clutch nonengagement, misengagement, or in-flight slippage.</p> <p><u>AFTER ENGINE COMBINING GEARBOX CLUTCH NONENGAGEMENT, MISENGAGEMENT, IN-FLIGHT SLIPPAGE</u></p> <p style="text-align: center;">NOTE</p> <p>A nonengaged engine is indicated by near zero torque, higher N₂, and much cooler ITT as compared to engaged engine.</p> <p>— Inspect</p> <p>1. Nonengagement.</p> <p>Perform inspection in accordance with Pratt & Whitney Canada PT6T-3/-3B Maintenance Manual.</p>		

CONDITIONAL INSPECTIONS

5-56. AFTER ENGINE COMBINING GEARBOX CLUTCH NONENGAGEMENT, MISENGAGEMENT, OR IN-FLIGHT SLIPPAGE (CONT)

DATA REFERENCE	INSPECTION TASK DESCRIPTION	INITIAL	
		MECH	OTHER
<p>Pratt & Whitney Canada PT6T-3/-3B Maintenance Manual</p> <p>SI 212-6 and Chapter 63</p> <p>SI 212-6 and BHT-212-CR&O</p>	<p>2. Misengagement.</p> <p style="text-align: center;">NOTE</p> <p>If a sprag clutch has failed to engage, and/or subsequently engages with or without audible or physical (helicopter jolt) indications, proceed as follows:</p> <p style="padding-left: 40px;">a. Combining gearbox shall be removed and inspected in accordance with Pratt & Whitney Canada PT6T-3/-3B Maintenance Manual.</p> <p style="padding-left: 40px;">b. Inspect transmission spiral bevel gear as follows:</p> <p style="padding-left: 80px;">(1) Gain access to left side of transmission and remove rotor brake and quill assembly.</p> <p style="padding-left: 80px;">(2) Utilizing rotor brake quill port opening, inspect all 62 teeth of main spiral bevel gear convex side for unsatisfactory conditions such as scoring, hard lines, nicks, dents, chipping, metal deformation, etc. Inspect all 62 teeth on spiral bevel gear concave side. Refer to Figure 5-6 for unacceptable conditions of spiral bevel gear.</p> <p style="text-align: center;">NOTE</p> <p>Inspection mirrors and a suitable light are required. Turn rotor slowly to permit inspection of all gear teeth.</p> <p style="padding-left: 80px;">(3) Remove and replace any gear that does not meet inspection requirements set forth in step (2). Overhaul rotor brake quill.</p>		

CONDITIONAL INSPECTIONS

5-56. AFTER ENGINE COMBINING GEARBOX CLUTCH NONENGAGEMENT, MISENGAGEMENT, OR IN-FLIGHT SLIPPAGE (CONT)

DATA REFERENCE	INSPECTION TASK DESCRIPTION	INITIAL MECH OTHER	
<p>SI 212-6 and Chapter 63</p> <p>BHT-212-CR&O</p>	<p style="text-align: center;">NOTE</p> <p>Components removed from a helicopter for evaluation following combining gearbox clutch nonengagement, misengagement, or in-flight slippage shall be evaluated as an interrelated group. Removal records accompanying each component shall cross-reference part and serial numbers of other drive system components removed for evaluation.</p> <p>(4) Install rotor brake and quill.</p> <p>(5) Install cowling and inspection panels.</p> <p>(6) Perform a 15 minute ground run to determine if any oil leaks are present at rotor brake quill assembly.</p> <p>c. Perform inspection in accordance with compressor stall or surge inspection (paragraph 5-52), except drive train shall be inspected as follows:</p> <p>(1) Visually inspect main rotor mast and controls for damage. If signs of yielding are evident, transmission and mast assembly and any other damaged components shall be replaced.</p> <p>(2) Visually inspect tail rotor driveshaft for damage.</p> <p>(3) Remove output quill from tail rotor gearbox and inspect both sides of gear teeth for scoring, scuffing, or other damage or marks indicating excessive load.</p>		

CONDITIONAL INSPECTIONS

5-56. AFTER ENGINE COMBINING GEARBOX CLUTCH NONENGAGEMENT, MISENGAGEMENT, OR IN-FLIGHT SLIPPAGE (CONT)

DATA REFERENCE	INSPECTION TASK DESCRIPTION	INITIAL MECH OTHER	
<p>Pratt & Whitney Canada PT6T-3/-3B Maintenance Manual</p>	<p style="text-align: center;">NOTE</p> <p>If a tail rotor driveshaft has failed or yielded, all tail rotor driveshafts, hanger assemblies, intermediate gearbox, and tail rotor gearbox shall be replaced, and tail rotor drive quill in transmission shall be removed and inspected for damage in accordance with the compressor stall inspection (paragraph 5-46). If scoring, scuffing, or other damage or marks indicate excessive load are found in intermediate gearbox or tail rotor gearbox, but tail rotor driveshafts are serviceable, gearbox(es) that are not serviceable shall be replaced.</p> <p>3. In-flight clutch slippage.</p> <p style="text-align: center;">NOTE</p> <p>If clutch slippage is confirmed or suspected, proceed as follows:</p> <p>a. Combining gearbox shall be removed and inspected in accordance with Pratt & Whitney Canada PT6T-3/-3B Maintenance Manual.</p> <p>b. Inspect spiral bevel gear in accordance with misengagement inspection step b, substep (2). If spiral bevel gear is damaged, perform misengagement inspection given in step c.</p>		

COMPONENT OVERHAUL SCHEDULE

5-57. COMPONENT OVERHAUL SCHEDULE

The Component Overhaul Schedule (Table 5-1) provides the time interval between overhaul for each applicable helicopter component.

WARNING

DO NOT APPLY TOLERANCES TO PARTS WITH A LIMITED AIRWORTHINESS LIFE (CHAPTER 4).

WARNING

DO NOT EXCEED RETIREMENT LIFE FOR CRITICAL COMPONENTS. REFER TO AIRWORTHINESS LIMITATIONS SCHEDULE (CHAPTER 4).

SOME PARTS INSTALLED AS ORIGINAL EQUIPMENT ON MILITARY HELICOPTERS MAY HAVE A LOWER AIRWORTHINESS LIFE AND/OR OVERHAUL SCHEDULE THAN WHEN USED ON A COMMERCIAL HELICOPTER. CONSEQUENTLY, PARTS THAT HAVE BEEN USED ON MILITARY HELICOPTERS SHOULD NOT BE USED ON COMMERCIAL HELICOPTERS.



OVERHAUL SCHEDULE FOR SOME KIT COMPONENTS AND/OR PARTS IS NOT COVERED IN THIS SCHEDULE. REFER TO APPLICABLE SERVICE INSTRUCTIONS FOR KIT COMPONENTS SCHEDULE.

NOTE

Refer to paragraph 5-1 for information on inspection and overhaul tolerance.

NOTE

Neither assignment of a time period for overhaul of a component or failure to assign a time period for overhaul of a component constitutes a warranty of any kind. The only warranty applicable to helicopter and any component is that warranty included in the Purchase Agreement for the helicopter or component.

The overhaul interval specified for any given part number contained in this Component Overhaul Schedule applies to all successive dash numbers (or suffixes) for that item unless otherwise specified.

Refer to Pratt & Whitney Canada PT6T-3/-3B bulletins for engine and related component overhaul intervals.

Table 5-1. Component Overhaul Schedule



NOMENCLATURE	PART NUMBER 	OVERHAUL INTERVAL (HOURS)
ROTORS		
Stabilizer Bar Assembly	204-011-326-013	 1000 hours/ On-condition
Swashplate and Support Assembly	204-011-400-017	On-condition

Table 5-1. Component Overhaul Schedule (Cont)















NOMENCLATURE	PART NUMBER 	OVERHAUL INTERVAL (HOURS)
ROTORS (CONT)		
Scissors and Sleeve Assembly	204-011-401-019	On-condition
Main Rotor Hub Assembly	204-012-101-009	2400 hours
Main Rotor Hub Assembly	212-510-001-103	 2400 hours
Tail Rotor Hub Assembly	212-010-701-001	1000 hours
Tail Rotor Hub Assembly	212-011-701-001	2500 hours
Tail Rotor Installation	209-011-700-003	
Tail Rotor Installation	212-011-700-001	
POWER TRAIN		
Rotor Brake Quill	412-040-123-101	3000 hours
Transmission	212-040-001-115, -119, -123, and -127	 1000 hours
Transmission	212-040-001-131	 1500 hours
Transmission	212-040-001-059, -137, and Subsequent	  6000 hours
Transmission	212-540-002-103	   6000 hours
Quill Assembly, Auxiliary Equipment	212-040-703-105	 1000 hours
Intermediate Gearbox Assembly	212-040-003-007	3000 hours
Intermediate Gearbox Assembly	212-040-003-023	5000 hours
Intermediate Gearbox Assembly	212-540-001-105	 5000 hours
Tail Rotor Gearbox Assembly	212-040-004-005	3000 hours
Tail Rotor Gearbox Assembly	212-040-004-009	5000 hours
Tail Rotor Gearbox Assembly	212-540-001-107	 5000 hours



Table 5-1. Component Overhaul Schedule (Cont)









NOMENCLATURE	PART NUMBER 	OVERHAUL INTERVAL (HOURS)
POWER TRAIN (CONT)		
Engine to Transmission (Main) Driveshaft	212-040-005-003	1000 hours
Engine to Transmission (Main) Driveshaft	212-040-005-007	3000 hours
Mast Assembly with 204-040-136-009 Bearing	204-040-366-015	1000 hours
Mast Assembly with 212-040-136-001 Bearing		2500 hours
Mast Assembly	204-040-366-017	2500 hours
Mast Assembly	204-040-366-021	 5000 hours
Mast Assembly	212-540-002-105	  5000 hours
Tail Rotor Driveshaft Hanger Assembly	212-040-600-001	3000 hours
Tail Rotor Hub Assembly	212-011-701-125	 2500 hours
HYDRAULIC		
Cylinder Assembly (Servo Actuator)	212-076-004-003	 1000 hours/ On-condition
Cylinder Assembly (Servo Actuator)	212-076-004-005	On-condition
Cylinder Assembly (Flight Control)	212-076-005-007	2500 hours
POWER PLANT		
Engine Combining (Reduction) Gearbox	PT6T3/-3B	 3500 hours
Starter Generator	209-060-221-001	1000 hours
Starter Generator	200SG119Q	1000 hours
Fire Extinguisher Container	209-062-908-001	 5 years

Table 5-1. Component Overhaul Schedule (Cont)**NOTES:**

- ① Operating time specified for overhaul of any given part number in this schedule applies to all successive dash numbers (or suffixes), unless otherwise specified.
- ② If tube assemblies 212-010-311-ALL or 540-011-319-001 are installed on stabilizer bar assembly 204-011-326, overhaul interval is conditional.
- ③ Overhaul the following items every 2500 hours of operation:
- a. Idler assembly 209-011-711-ALL
 - b. Lever assembly 209-011-712-ALL
 - c. Nut 212-010-706-ALL
 - d. Crosshead 212-010-707-ALL or 212-010-775-ALL
 - e. Link assembly 209-011-713-ALL
- ④ Overhaul schedule of transmission quills is same as transmission in which quills are installed, with exception of rotor brake quill.
- ⑤ Special inspection is required at 3000 hours, and overhaul is 6000 hours.
- ⑥ Special inspection is required at 3000 hours and overhaul is 5000 hours. If mast assembly 204-040-366-021 is installed in transmission 212-040-001-115, -123, and -131, mast assembly TBO is 2500 hours.
- ⑦ If cylinders have Greene, Tweed type seals installed, overhaul is conditional. Cylinders with assembly date of April 30, 1974 or later were fitted with Greene, Tweed type seals at manufacturer. However, cylinders without Greene, Tweed type seals shall be overhauled at 1000 hours.
- ⑧ Engine combining gearboxes that have incorporated the preceding referenced Pratt & Whitney Canada Service Bulletin numbers 5119, 5177, 5185, 5186, 5198, and 5199 are increased to 4000 hours TBO.
- ⑨ Refer to TB 212-91-138.
- ⑩ Refer to BHT-212-SI-87 for maintenance information.
- ⑪ Hydrostatic test in accordance with specification DOT-4 DA, DOT-4 DS700, or DOT-SP-7945, as marked on the reservoir, every 5 years or prior to refill after leakage or discharge. Extensions to this item are not permitted.