



A Textron Company

ALERT SERVICE BULLETIN

214-12-73
25 May 2012

MODEL AFFECTED: 214B/B-1

SUBJECT: MAIN ROTOR HUB ASSEMBLY SPINDLE ASSEMBLY, P/N 214-010-103, MANDATORY INSPECTION AND OVERHAUL REQUIREMENTS.

HELICOPTERS AFFECTED: Serial number 28001 through 28070.

COMPLIANCE: PART I: At the next 25 Hour Inspection and at each subsequent 25 Hour Inspection.

PART II: At P/N 214-010-103 Spindle Assembly Overhaul (2500 hours)

DESCRIPTION:

THIS ASB CANCELS AND SUPERSEDES TECHNICAL BULLETIN 214-02-93 DATED 8-30-2002.

As the result of the investigation of a cracked spindle assembly, BHTI has determined that additional inspection and overhaul tasks are necessary and should be considered mandatory.

The 25 Hour Inspection requirement is expanded (PART I of this bulletin) to include a specific visual inspection of the spindle for cracks and bushing wear at the four spindle to yoke attachment holes.

In addition, the spindle to yoke attachment hole bushings must be removed at spindle assembly overhaul (2500 hours), the spindle hole bores inspected for condition/wear, and new bushings reinstalled (PART II of this bulletin). Because this is a critical task involving specialized tooling and processes, bushing removal/installation and hole bore inspection will be accomplished only by Bell Helicopter.

These changes have been incorporated into both the maintenance and component repair and overhaul manuals as appropriate. Refer to the Accomplishment Instructions for a summary of the changes to each publication.

PART III of this bulletin provides information for returning spindles to Bell Helicopter for the 2500 hour overhaul bushing replacement.

APPROVAL:

The engineering design aspects of this bulletin are FAA/ODA approved.

CONTACT INFO:

For any questions regarding this bulletin, please contact:

Bell Helicopter Product Support Engineering - Medium Military Helicopters
Tel: 817-280-3548 / mts-medium@bellhelicopter.textron.com

MANPOWER:

Approximately 1.0 man-hour is required to complete this bulletin. This estimate is based on hands-on time, and may vary with personnel and facilities available.

WARRANTY:

There is no warranty credit applicable for parts or labor associated with this bulletin.

MATERIAL:

None required.

SPECIAL TOOLS:

None required.

WEIGHT AND BALANCE:

Not affected

ELECTRICAL LOAD DATA:

Not affected.

REFERENCES:

BHT-214B-IPB Illustrated Parts Breakdown, Chapter 62
BHT-214B-MM-1 Maintenance Manual, Chapters 5 and 65
BHT-214B-CR&O Component Repair and Overhaul Manual, Chapter 65
Information Letter GEN-04-98 Rev C

PUBLICATIONS AFFECTED:

None affected

ACCOMPLISHMENT INSTRUCTIONS:

PART I - REVISION TO MAINTENANCE MANUAL.

-NOTE-

The following maintenance manual changes were incorporated at revision 7.

1. Chapter 5, Paragraph 5-9, 25-Hour Inspection:

MAIN ROTOR HUB

Inspect main rotor hub spindle assembly bushings.

2. Chapter 65, paragraph 65-17:

65-17. MAIN ROTOR HUB SPINDLE ASSEMBLIES – INSPECTION

NOTE

Required each 25 hours per Chapter 5

Inspect the visible areas of the main rotor spindles for general condition and the following:

NOTE

Refer to BHT-214B-CR&O-1 for damage limits.

1. Cracks at the four spindle to yoke attachment holes. Cracked spindles are non-airworthy and must be replaced.
2. Evidence of looseness/movement of the spindle to yoke attachment hole bushings. If bushing looseness/movement is verified or suspected, remove spindle for overhaul inspection/repair.

PART II - REVISION TO COMPONENT REPAIR AND OVERHAUL MANUAL.

-NOTE-

The following component repair and overhaul manual changes were incorporated at revision 3.

1. Chapter 65, paragraph 65-12.2.c.(2) and (3):

c. Inspect spindle (7, Figure 65-5) as follows:

(2) Yoke to spindle attachment bushings for fretting/looseness. Bushings exhibiting evidence of fretting, looseness, or movement must be replaced.

CAUTION

THE FOLLOWING PROCEDURE MAY ONLY BE
ACCOMPLISHED BY BELL HELICOPTER

(3) At each 2500 hour overhaul, remove yoke to spindle attachment bushings, inspect spindle bores for damage, and install new bushings.

2. Figure 65-7 (sheet 4)

See page 6 of this bulletin.

3. Figure 65-8 (sheet 2)

See page 7 of this bulletin.

4. Figure 65-8 (sheet 3)

See page 8 of this bulletin.

5. Figure 65-9 (sheet 1)

See page 9 of this bulletin.

6. Paragraph 65-13.4:

4. Spindle Repair

NOTE

Removal/installation of bushings and spindle bore inspection may only be accomplished by Bell Helicopter

- a. Refer to preceding step 3 for general repair.
- b. Worn or loose spindle to yoke attachment bushings must be replaced and the spindle bores inspected for damage.

PART III – PARTS RETURN TO BELL HELICOPTER TEXTRON

1. Spindles being returned to Bell Helicopter for the 2500 hour overhaul bushing replacement/inspection are to be returned with an RMA. Refer to Information Letter GEN-04-98 Rev C for return procedures.

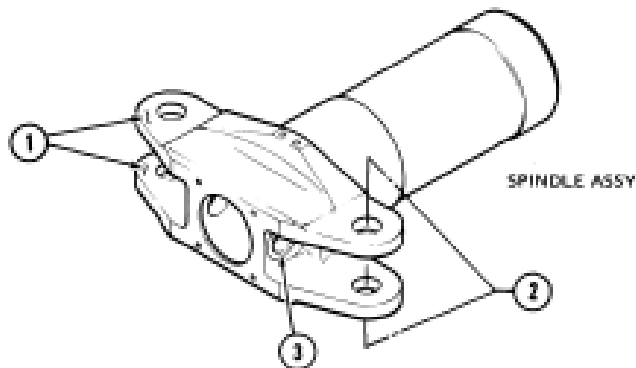

NO.	ITEM	REUSE SPINDLE	SCRAP SPINDLE-STRAPS-PINS	SCRAP HUB ASSY
	NOMENCLATURE			
1	Spindle lug faces, eight places	No visible deformation on lug face when checked with a straight edge	Any visible deformation on both sides of a lug when checked with a straight edge	
2	Spindle to yoke attachment bushings	Unworn 214-040-129 pin shall fit through the spindle tangs without interference. Hole round within 0.0005 inch.	Any significant bind or looseness. Out-of-round exceeds 0.0005 inch.	
3	Strap Pin Hole	Hole round within 0.0005 inch.	Out-of-round exceeds 0.0005 inch.	Out-of-round exceeds 0.0015 inch with larger dimension in a spanwise direction.

214Bcrs_65_0004

Figure 65-7. Main Rotor Hub Conditional Inspection (Sheet 4 of 6)

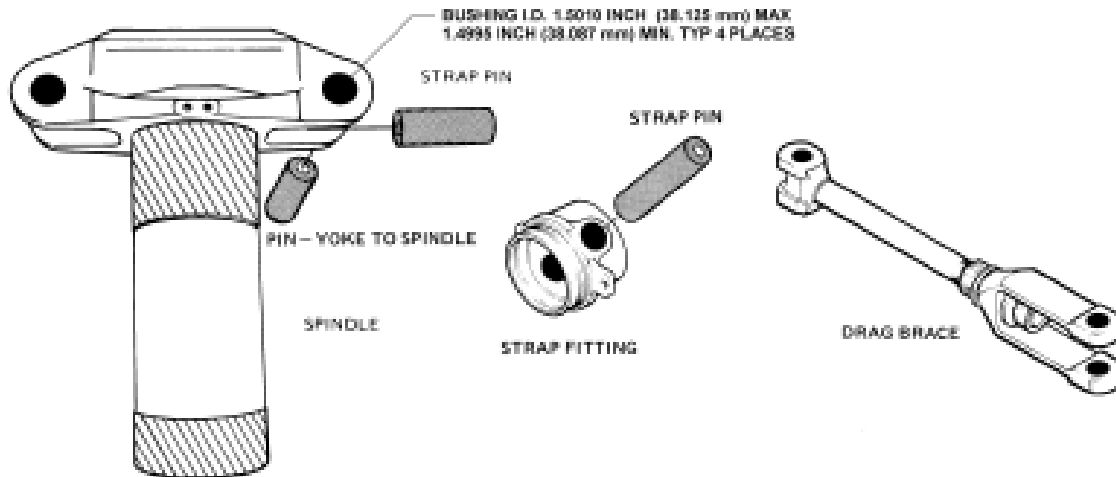

DAMAGE AREA REPAIR SYMBOLS





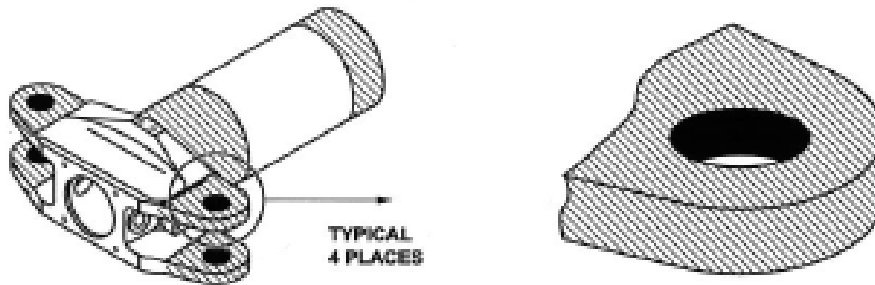

TYPE OF DAMAGE	MAXIMUM DEPTHS AND REPAIR AREAS		
	0.001 Inch (0.0254 mm)	0.010 Inch (0.254 mm)	0.004 (0.1016 mm)
MECHANICAL DAMAGE	0.001 Inch (0.0254 mm)	0.010 Inch (0.254 mm)	0.004 (0.1016 mm)
CORROSION DAMAGE	0.001 Inch (0.0254 mm)	0.010 Inch (0.254 mm)	0.004 (0.1016 mm)
MAXIMUM AREA PER FULL DEPTH REPAIR	0.50 Inch Square (322.88 mm sq)	Not Critical	0.50 Inch Square (322.88 mm sq)
NUMBER OF REPAIRS	Two	Not Critical	Two Per Shaded Area
EDGE CHAMFER	0.010 Inch (0.254 mm)	0.040 Inch (1.016 mm)	0.010 Inch (0.254 mm)
MOUNT BOLT BORE DAMAGE:	0.001 Inch for 1/4 of Circumference, size limits apply.		
CRACKS:	No cracks allowed.		

Figure 65-8. Main Rotor Hub Mechanical and Corrosion Damage Limits (Sheet 2 of 7)



DAMAGE AREA REPAIR SYMBOLS

TYPE OF DAMAGE	MAXIMUM DEPTH AND REPAIR AREAS	
		
MECHANICAL DAMAGE	0.010 INCH (0.254 mm)	0.004 INCH (0.1016 mm)
CORROSION DAMAGE	0.010 INCH (0.254 mm)	0.004 INCH (0.1016 mm)
MAXIMUM AREA PER FULL DEPTH REPAIR	NOT CRITICAL	0.50 SQ. INCH (322.588 sq. mm)
NUMBER OF REPAIRS	NOT CRITICAL	TWO PER SHADED AREA
EDGE CHAMFER	0.040 INCH (1.016 mm)	0.010 INCH (0.254 mm)
BUSHING BORE DAMAGE: ● DAMAGE MAY BE WORKED TO DIMENSIONS SHOWN BELOW ONLY.		
BORE DIAMETER		
(BUSHING REMOVED) - STANDARD 1.6875 to 1.6980 INCH (42.862 to 42.875 mm)  		
- OVERSIZE 1.7075 to 1.7180 INCH (43.376 to 43.383 mm)		
CRACKS:	NO CRACKS ALLOWED	

NOTES

-  Measured twice (90° apart) at top and bottom of each hole.
-  Typical 4 places.

214B_001_00_0000

Figure 65-8. Main Rotor Hub Mechanical and Corrosion Damage Limits (Sheet 3 of 7)

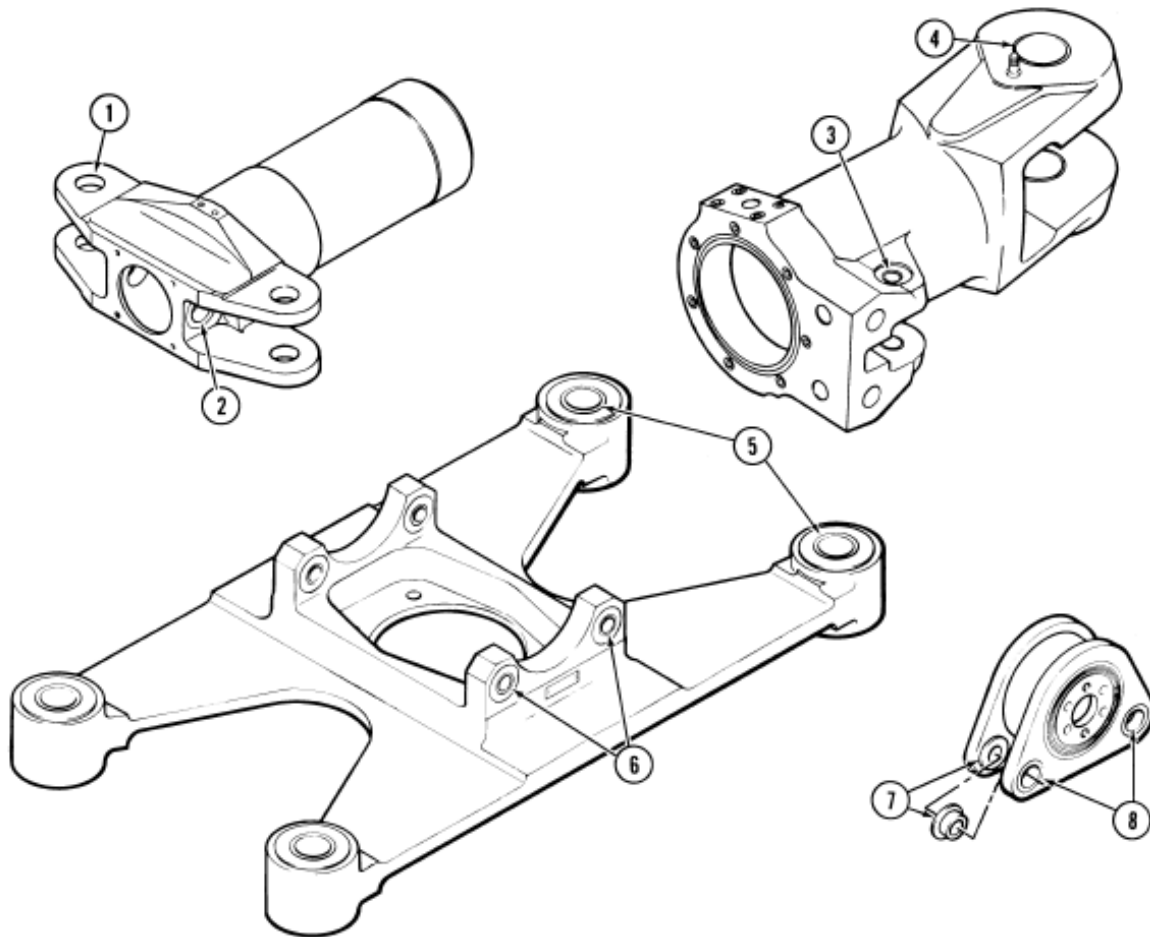

HOLE NO.	NOMENCLATURE	HOLE DIAMETER	
		MIN.	MAX.
1	Bushings, Spindle to Yoke	1.4995	1.5010
2	Hole, Strap Pin	1.625	1.6265
3	Bushings, Drag Brace Installation	1.000	1.002
4	Bushings, Main Blade Bolt	2.875	2.877
5	Bushings, Spindle Installation	1.4995	1.5005
6	Bushing, Bearing Installation	0.7495	0.7505
7	Bushing, Bearing to Yoke	0.7495	0.7510
8	Bushing, Slip Bushing Installation	1.0000	1.0015

214010-120

Figure 65-9. Main Rotor Hub Hole Wear Limits (Sheet 1 of 2)

21 MAR 2008 Rev. 3 65-27