



A Textron Company

## **ALERT SERVICE BULLETIN**

**206-23-142**

27 February 2023

Revision A, 27 March 2023

**MODEL AFFECTED:** 206A/B and TH-67

**SUBJECT:** PILOT CYCLIC STICK ASSEMBLY P/N 206-001-344-001/-101/-105, INSPECTION AND REPAIR OF

**HELICOPTERS AFFECTED:** Serial numbers 4 through 4690 and 5101 through 5313.

**COMPLIANCE:**

**PART I:** Within 100 flight hours or 90 days, whichever occurs first, following the release date of this bulletin.

**PART II:** Prior to next flight as required by **PART I**.

**PART III:** Within 300 flight hours or 6 months, whichever occurs first, after accomplishment of **PART II**, and every 300 flight hours or 6 months whichever occurs first thereafter until accomplishment of **PART V**.

**PART IV:** Within 1200 flight hours or 24 months whichever occurs first after accomplishment of **PART I** and every 1200 flight hours or 24 months thereafter.

**PART V:** Within 24 months after accomplishment of **PART II**.

### **DESCRIPTION:**

Bell has recently received a report of a fractured pilot cyclic stick found while performing the Interior and Prestart Check of the 407 Rotorcraft Flight Manual (RFM). The fracture originated at the upper slotted area near the lower base of the cyclic stick. Consequently, helicopters of a mixed fleet were inspected, and additional cyclic sticks were found cracked on 407 helicopters.

ASB 206-23-142RA

Page 1 of 16

Approved for public release.

The cyclic sticks inspected on 206 series did not reveal any cracks; however, some sticks were found with corrosion damage that could lead to cracking.

This bulletin mandates an initial 10X magnifying glass inspection of the lower 4.0 inches (101.6 mm) of the pilot cyclic stick and provides a repair of cracked cyclic stick tube assemblies 206-001-342-001/-101.

The bulletin also replaces the current 1200 hour inspection of the cyclic control stick with a 1200 hour or 24 month whichever comes first 10 X magnifying glass inspection.

**PART I** of this bulletin mandates a 10X magnifying glass inspection of the lower four inches of the cyclic stick tube assembly (1, Figure 1).

**PART II** of this bulletin provides a repair for a cracked 206-001-342-001/-101 cyclic stick tube assembly consisting of a stop drill procedure. This repair can only be performed for cracks initiating in the upper slot on the lower part of the stick tube. The maximum repairable crack length is shown in Figure 2 of this bulletin.

**PART III** of this bulletin introduces a 300 flight hour or 6 month, whichever occurs first, 10X magnifying glass visual inspection of the cyclic stick tubes that have been repaired per **PART II**. This inspection is a recurring inspection until accomplishment of **PART V**.

**PART IV** of this bulletin replaces the 1200 hour inspection of the cyclic control stick (BHT-206A/B-SERIES-MM, Chapter 5, para 5-30).

**PART V** of this bulletin mandates the replacement of the repaired cyclic stick tube 206-001-342-001FM or 206-001-342-101FM accomplished in **PART II**.

**Revision A** of this bulletin requires customers to contact Bell Product Support when finding a cracked cyclic stick tube assembly. Figures with drill bushings revised to allow a final ream of .1875-inch (4.763mm).

Applicability of this bulletin to any spare part must be determined prior to its installation on an affected helicopter.

#### **APPROVAL:**

The engineering design aspects of this bulletin are Transport Canada Civil Aviation (TCCA) approved.

#### **CONTACT INFO:**

For any questions regarding this bulletin, please contact:

Bell Product Support Engineering  
Tel: 1-450-437-2862 / 1-800-363-8023 / [productsupport@bellflight.com](mailto:productsupport@bellflight.com)

**MANPOWER:**

Approximately 4.0 man-hours are required to complete **PART I** of this bulletin.  
 Approximately 6.0 man-hours are required to complete **PART II** of this bulletin.  
 Approximately 2.0 man-hours are required to complete **PART III** of this bulletin.  
 Approximately 2.0 man-hours are required to complete for **PART IV** of this bulletin.  
 Approximately 2.0 man-hours are required to complete **PART V** of this bulletin.

This estimate is based on hands-on time and may vary with personnel and facilities available.

**WARRANTY:**

There is no warranty credit applicable for parts or labor associated with this bulletin.

**MATERIAL:****Required Material:**

The following material is required for the accomplishment of this bulletin and may be obtained through your Bell Supply Center.

<u>Part Number</u>	<u>Nomenclature</u>	<u>Qty (Note)</u>
206-001-342-001	Cyclic Stick Tube Assy	1 (1,2)
206-001-342-101	Cyclic Stick Tube Assy	1 (1,3)

**NOTES:**

1. Only required if the cyclic stick tube exceeds the mechanical and/or corrosion damage limits of **PART I**.
2. Used on helicopter serial number 4 through 3566.
3. Used on helicopter serial number 3567 through sub and 5101 through 5313.

**Consumable Material:**

The following material is required to accomplish this bulletin, but may not require ordering, depending on the operator's consumable material stock levels. This material may be obtained through your Bell Supply Center.

<u>Part Number</u>	<u>Nomenclature</u>	<u>Qty (Note)</u>	<u>Reference *</u>
2900-05806-00	Aluminum oxide abrasive cloth or paper (400 grit)	A/R	C-406
2230-05806-00	Paint Remover	1(1)	C-436
2230-00425-00	Primer, Epoxy Polyamide	1(1)	C-204
2230-06023-00	Coating, Polyurethane	1(1)	C-245
2100-00006-00	Cleaning Compound	1(1)	C-318

\* C-XXX numbers refer to the consumables list in the BHT-ALL-SPM, Standard Practices Manual

**NOTE 1:** The quantity indicated is the format the product is delivered in. Actual quantity required to accomplish the instructions in this bulletin may be less.

**SPECIAL TOOLS:**

Locally manufactured drill guide (Figure 4).  
Drill bushings for drill guide may be procured locally or through McMaster-Carr or Carr-Lane.

**WEIGHT AND BALANCE:**

Not affected.

**ELECTRICAL LOAD DATA:**

Not affected.

**REFERENCES:**

BHT-206A/B-SERIES-IPB Illustrated Parts Breakdown, Chapter 67  
BHT-206A/B-SERIES-MM Maintenance Manual, Chapter 67  
BHT-206B3-CR&O Component Repair and Overhaul Manual, Chapter 67  
BHT-ALL-SPM Standard Practices Manual, Chapter 6

**PUBLICATIONS AFFECTED:**

BHT-206A/B-SERIES-MM Maintenance Manual, Chapter 5 and 67  
BHT-206B3-CR&O Component Repair and Overhaul Manual, Chapter 67

**ACCOMPLISHMENT INSTRUCTIONS:**

**PART I: 206-001-342-001/-101 Cyclic Stick Tube Inspection**

-NOTE-

The cyclic stick tubes 206-001-342-001/-101 are currently on manual allocation due to limited quantities available.

1. Prepare the helicopter for maintenance.
2. Remove the pilot cyclic control stick (BHT-206A/B-SERIES-MM, Chapter 67).

-NOTE-

The lower 4.0 inches (101.6 mm) of cyclic stick assembly must be inspected using a 10X magnifying glass. The 3X magnifying glass inspection of the pilot cyclic stick in BHT-206B3-CR&O Chapter 67 will be revised to a 10X inspection in a future revision of the CR&O.

3. Clean the lower 4.0 inches (101.6 mm) of the removed cyclic stick assembly with cleaning compound (C-318) before inspection (1, Figure 1).
4. Visually inspect the lower 4.0 inches (101.6 mm) of the cyclic stick assembly for cracks with a 10X magnifying glass. Pay particular attention to the area adjacent to the two slots in the tube where the two bolts secure the tube when installed in the pivot assembly. As per Figure 2, cracks that extend past the edge of the slotted area are not repairable.
5. If no cracks are found, go to step 9 of this bulletin.
6. If a crack is found or suspected using the 10X magnifying glass visual inspection, disassemble the cyclic stick assembly by removing the cyclic stick grip assembly (BHT-206B3-CR&O, Chapter 67)
7. Remove the paint and primer with paint remover (C-436) and thoroughly inspect the lower end of the cyclic stick tube (1, Figure 1) using the fluorescent penetrant inspection (FPI) method (BHT-ALL-SPM, Chapter 6).
  - a. If a crack is found, accomplish **PART II** prior to next flight or replace the cracked cyclic stick tube assembly with a serviceable part meeting the intent of the bulletin.
  - b. The following inspection criteria apply to a cracked cyclic stick tube assembly eligible for the accomplishment of **PART II**:
    1. Cracks that extend past the edges of the slot are not permitted (Figure 2).
    2. Cracked slot lengths longer than 0.791 inch (20.09 mm) are not permitted.
  - c. If the crack length in the cyclic stick assembly exceeds the criteria of step 7.b, the cyclic stick tube assembly will be considered unserviceable and must be replaced by a serviceable cyclic stick tube assembly meeting the intent of this bulletin prior to next flight.
8. Customers finding a cracked cyclic stick tube must send an email to Bell Product Support Engineering at [productsupport@bellflight.com](mailto:productsupport@bellflight.com) with the following information:

- a. Subject Line: Helicopter model, serial number and ASB number.

**Example email subject line:**

206 (0004) – ASB 206-23-142RA

- b. The email shall include the following information:
  - (1) Total time in-service.
  - (2) Cyclic stick tube part number. Ex: 206-001-342-001 or (-101) as applicable.
  - (3) Clear in-focus pictures of the damaged cyclic stick tube assembly.
9. If no cracks are found, thoroughly clean the cyclic stick tube with water and mild detergent (C-318) to completely remove residual penetrant and developer.
  - a. Dry the cyclic stick assembly completely.
  - b. Restore removed primer (C-204) and organic finish with polyurethane coating (C-245) before installation of stick into pivot assembly (BHT-ALL-SPM, Chapter 4).
10. Reassemble the pilot cyclic stick assembly (BHT-206B3-CR&O, Chapter 67).
11. Install the pilot cyclic stick assembly (BHT-206A/B-SERIES-MM, Chapter 67).
12. Make an entry in the helicopter logbook and historical service records indicating compliance with **PART I** of this Alert Service Bulletin.

**PART II: Pilot cyclic stick assembly stop drill repair**

1. For cyclic stick tubes with cracks in the slotted area not exceeding the limits of Figure 2, carry out the following stop drill procedure:

-NOTE-

The maximum repairable crack length that can be stop drilled cannot be beyond the outside edge of the slot (Figure 2). The pilot hole for the stop drill must be in the full thickness of the tube, centered along the centerline of the slot and no further than 0.010-inch (.25 mm) from the edge of the slot (Figure 3, Sheet 1 of 2).

- a. Use an automatic center punch to mark the edge of the slot (Figure 3, Sheet 1 of 2).

## CAUTION

The location and orientation of the stop drill is critical. It is important to properly secure the cyclic stick tube prior to drilling to ensure the drill bit is oriented exactly through the centerline of the tube. Preferably the cyclic stick tube should be held in place in a fixing head and drilled on a milling machine. However, since this is not always achievable, Figure 4 shows an example of a drill guide that can be locally manufactured to ensure a clean and well-oriented stop drill hole. Figure 5 shows the installed workaid with the addition of various drill bushings for precise drilling and reaming.

- b. Locally manufacture a workaid (Figure 4) and procure drill bushings or have the cyclic stick tube stop-drilled in a milling machine.
- c. Install the drill guide on the cyclic stick tube (Figure 5) and line up with the center punch mark using the smallest drill bushing.
- d. Secure the drill guide by tightening the nuts only enough to stop the drill guide from moving. Confirm that the drill bushing hole is exactly in line with the center punch mark. Do not over-tighten nuts and bolts to avoid damaging the cyclic stick tube.
- e. Drill a pilot hole using the smallest drill guide. Use a drill stop to limit the drilling depth to avoid damaging the opposite side of the tube.

## -NOTE-

Stop drill holes must be free of all sharp edges and deburred.

- f. Increase the stop drill hole diameter until a final ream of 0.1875-inch (4.76 mm) is achieved. Deburr holes.
- g. Once the stop drill procedure is completed, carry out a fluorescent penetrant inspection (FPI) of the repaired area to ensure the crack is removed and there are no cracks in the stop drill bore. (BHT-ALL-SPM, Chapter 6).
- h. Thoroughly clean the cyclic stick tube with water and mild detergent (C-318) to completely remove residual penetrant and developer.
- i. Dry the cyclic stick assembly completely.

- j. Touch up the repaired area with epoxy polyamide primer (C-204). Refinish the repaired area as required to match the original finish with polyurethane coating (C-245) (BHT-ALL-SPM, Chapter 4).
2. The repaired cyclic stick tube assembly must be identified as follows:
    - a. Identify the lower part of the cyclic stick tube assembly directly above the pivot assembly by hand marking or stencil marking part number 206-001-342-001FM or 206-001-342-101FM (as applicable) with white or silver lettering. The size of the alpha-numeric lettering must be approximately 0.25 inch (6.35 mm) in height.
  3. Reassemble the pilot cyclic stick assembly (BHT-206B3-CR&O, Chapter 67).
  4. Install the pilot cyclic control stick (BHT-206A/B-SERIES-MM, Chapter 67).
  5. **PART III** and **PART V** of this bulletin are mandatory after completing **PART II**.
  6. Make an entry in the helicopter logbook and historical service records indicating compliance with **PART II** of this Alert Service Bulletin.

**PART III: Recurring inspection of cyclic stick tubes 206-001-342-001FM/101FM**

1. Prepare the helicopter for maintenance.
2. Remove the pilot cyclic control stick (BHT-206A/B-SERIES-MM, Chapter 67).
3. Clean the lower 4.0 inches (101.6 mm) of the removed cyclic stick assembly with cleaning compound (C-318) before inspection (1, Figure 1).
4. Inspect the lower 4.0 inches (101.6 mm) of the cyclic stick assembly using a 10X magnifying glass. Pay particular attention to the stop-drilled repair area.

-NOTE-

Cracks in the circled areas of the inner sleeve inboard of the stop-drilled holes as shown in Figure 3 (Sheet 2 of 2) are not cause for rejection.

- a. If any cracks are found, remove the cyclic control stick assembly from service and replace with a serviceable cyclic stick assembly meeting the intent of this bulletin.
  - b. If no cracks are found, install the cyclic control stick (BHT-206A/B-SERIES-MM, Chapter 67).
5. Make an entry in the helicopter logbook and historical service records indicating compliance with **PART III** of this Alert Service Bulletin.



6. Repeat **PART III** every 300 flight hours or 6 months, whichever occurs first until accomplishment of **PART V**.

**PART IV: Introduction of a new 1200 Hour / 24 Month Scheduled Inspection of the cyclic control stick assembly.**

-NOTE-

The following inspection replaces the 1200 HOUR CYCLIC CONTROL STICK inspection (BHT-206A/B-SERIES-MM, Chapter 5).

1. Remove the pilot cyclic control stick assembly (BHT-206A/B-SERIES-MM, Chapter 67).
2. Clean the lower 4.0 inches (101.6 mm) of the removed cyclic stick tube assembly with cleaning compound (C-318) before inspection (1, Figure 1).
3. Visually inspect the pilot cyclic stick tube assembly for cracks with a 10X magnifying glass. Pay particular attention to the area adjacent to the slots in the tube where the two bolts secure the tube in the pivot assembly.
4. If a crack is suspected using the 10X magnifying glass visual inspection, disassemble the cyclic stick assembly by removing the cyclic stick grip assembly (BHT-206B3-CR&O, Chapter 67).
5. Remove the paint and primer with paint remover (C-436) and thoroughly inspect lower end of the cyclic stick tube assembly using the fluorescent penetrant inspection (FPI) method (BHT-ALL-SPM, Chapter 6).
6. If any cracks are found, replace the cyclic stick tube assembly, or perform the repair as per **PART II** of this bulletin.
7. If no cracks are found, inspect the cyclic stick tube assembly for mechanical and corrosion damage as follows:
  - a. Damaged and repaired areas must be separated by 1.0-inch (25 mm) minimum.
  - b. Mechanical damage must not exceed 0.005-inch (0.127 mm) depth and 1/3 of the tube circumference.
  - c. Corrosion damage must not exceed 0.0025-inch (0.0635 mm) depth before, and 0.005-inch (0.127 mm) after repair and 1/3 of the tube circumference.
  - d. Identify as unserviceable any cyclic stick tube that does not meet these criteria.

8. Inspect the bore of the cyclic pivot assembly where the stick tube is installed for mechanical and corrosion damage. Bore damage must not exceed 0.002-inch (0.051 mm) for ¼ of the circumference. Limit of one repair per bore. Repair or replace pivot assembly as required.
9. For cyclic stick tubes inspected and found serviceable, polish out any acceptable damage using 400 to 600 grit abrasive cloth or paper (C-406).
10. Thoroughly clean cyclic stick tube with water and mild soap (C-318) to completely remove residual penetrant and developer. Dry part completely.
11. Touch up area with epoxy polyamide primer (C-204). Refinish paint as required to match the original finish with polyurethane coating (C-245).
12. If the pilot cyclic stick assembly was disassembled, re-assemble the pilot cyclic stick assembly (BHT-206B3-CR&O, Chapter 67).
13. Install pilot cyclic stick assembly (BHT-206A/B-SERIES-MM, Chapter 67).
14. Make an entry in the helicopter logbook and historical service records indicating compliance with **PART IV** of this Alert Service Bulletin.

#### **PART V: Replacement of the stop-drilled cyclic stick tube**

1. Prepare the helicopter for maintenance.
2. Remove the cyclic stick tube 206-001-342-001FM or 206-001-342-101FM that was repaired per **PART II** of this bulletin.
3. Install a serviceable 206-001-342-001 or 206-001-342-101 cyclic stick tube assembly as applicable (BHT-206A/B-SERIES-MM, Chapter 67).
4. Make an entry in the helicopter logbook and historical service records indicating compliance with **PART V** of this Alert Service Bulletin.

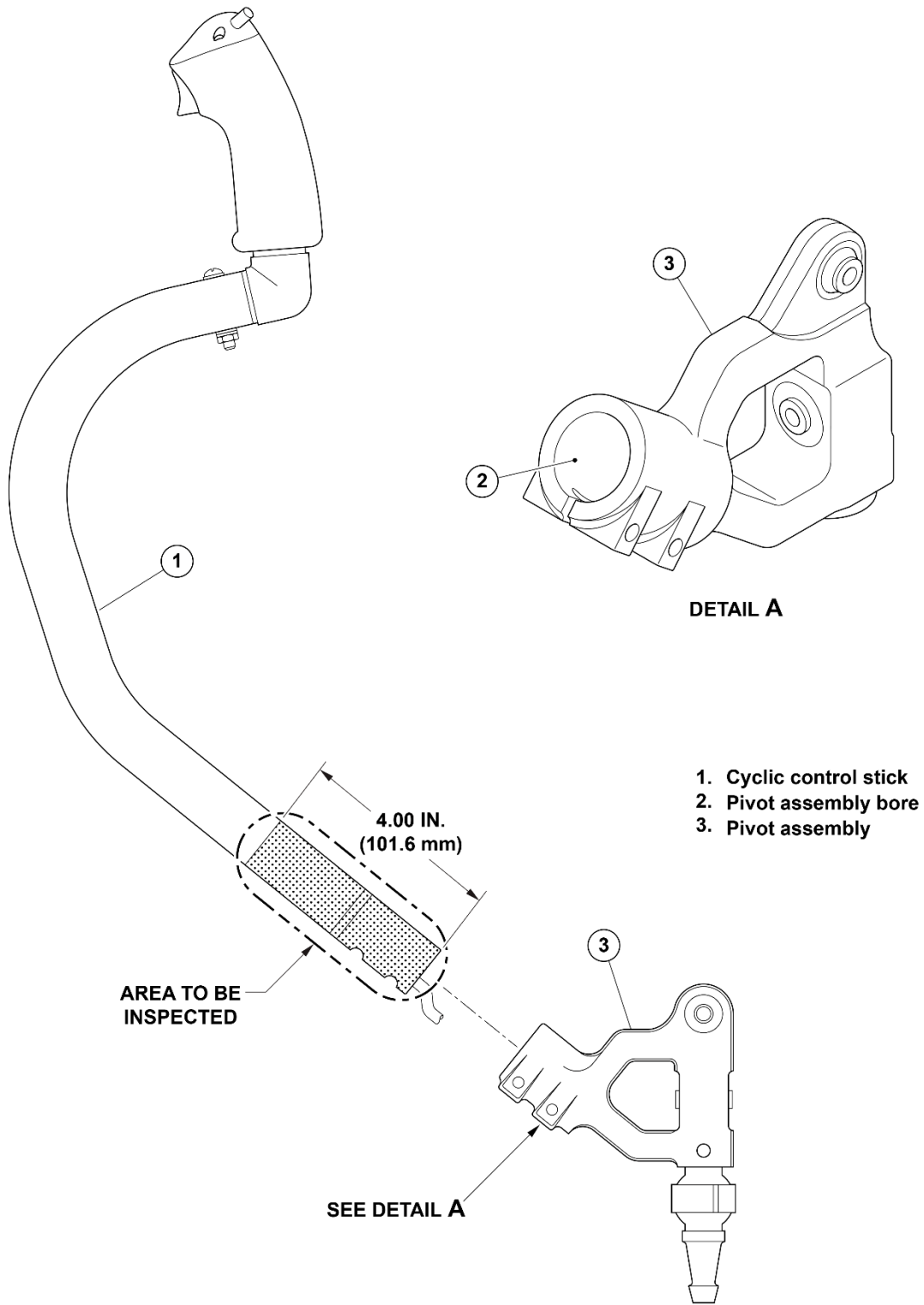

- 1. Cyclic control stick
- 2. Pivot assembly bore
- 3. Pivot assembly

22568\_001

**Figure 1 – Pilot Cyclic Stick – 10X Magnifying Glass Inspection Area**

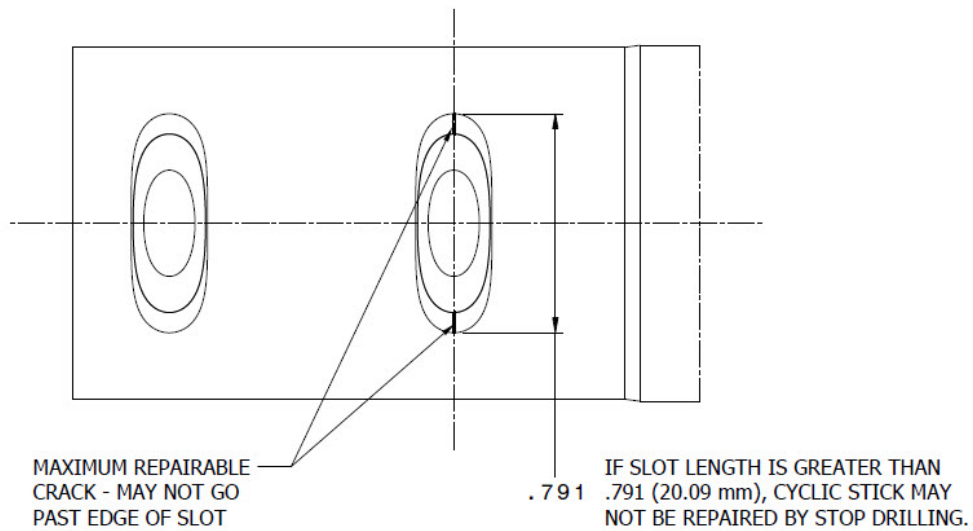
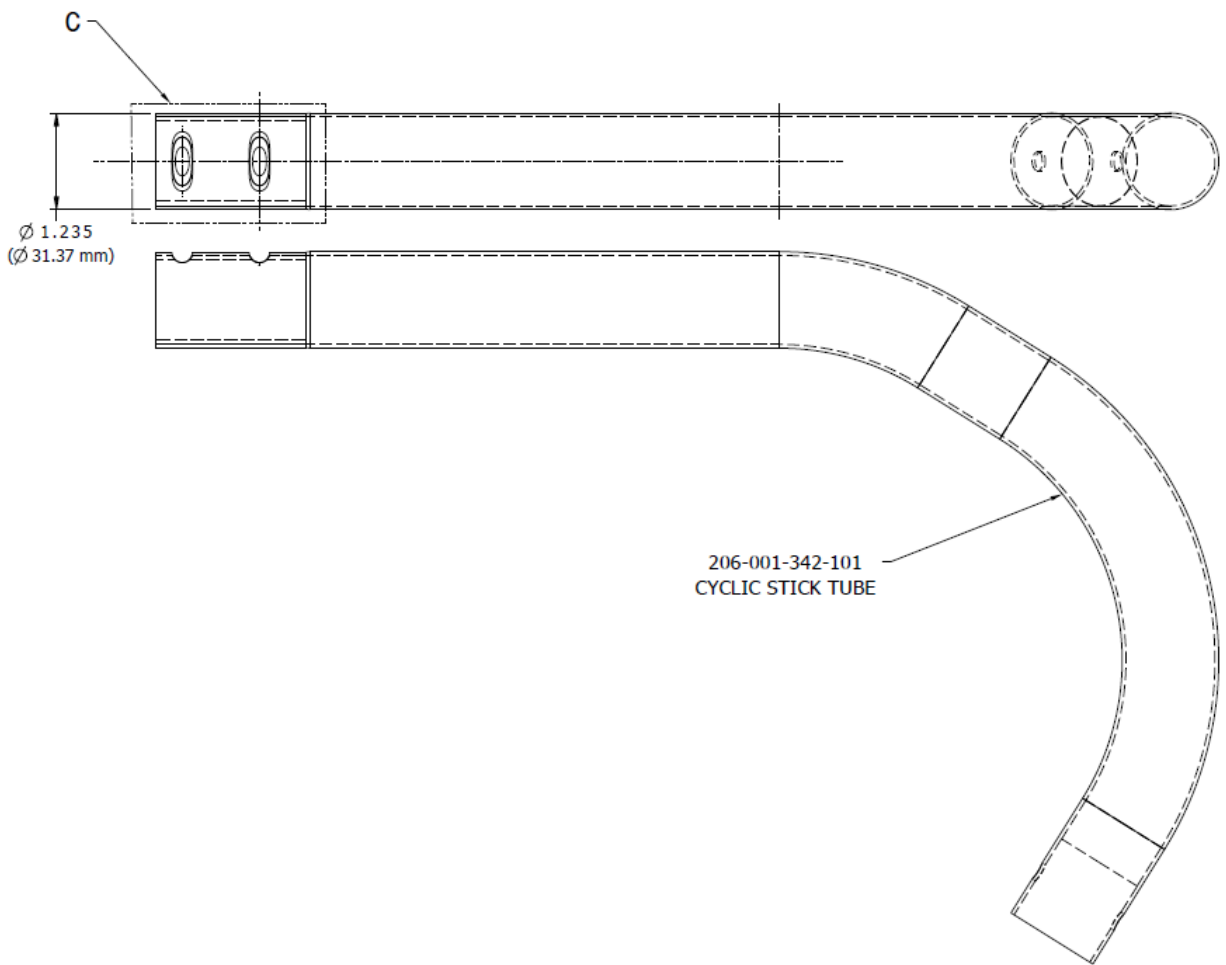

DETAIL C

Figure 2- Typical Crack Location and Maximum Repairable Crack Length

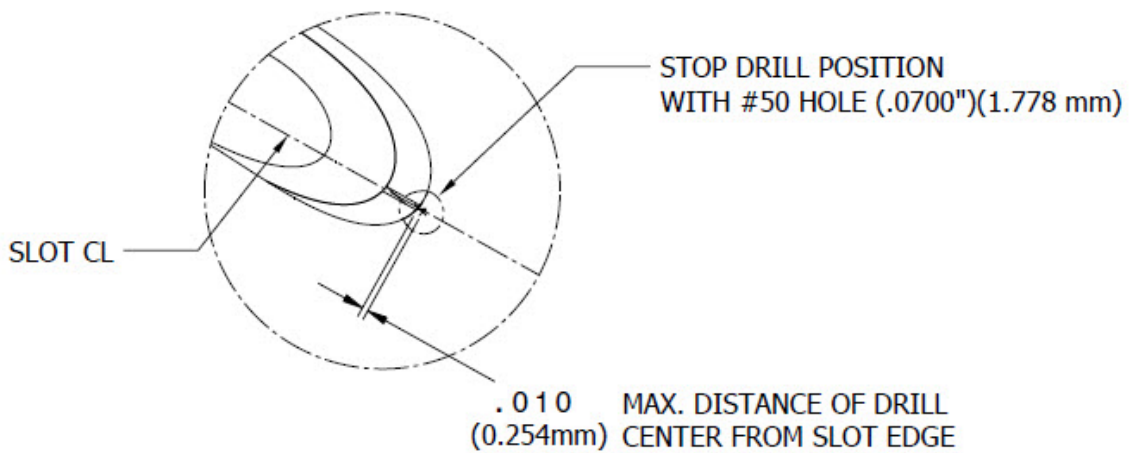
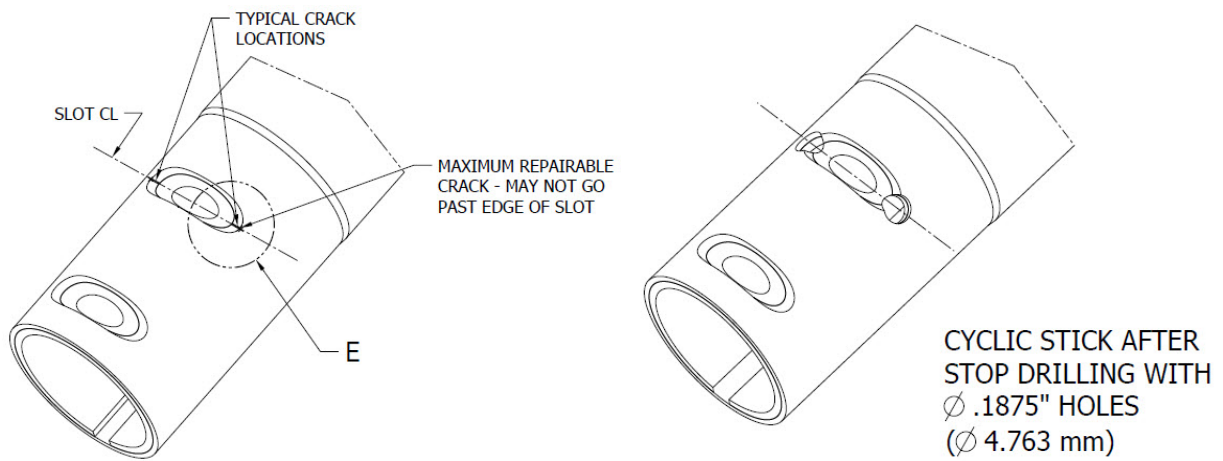

**DETAIL E**

**Figure 3 (Sheet 1 of 2) – Pilot Hole Location for Stop Drill**

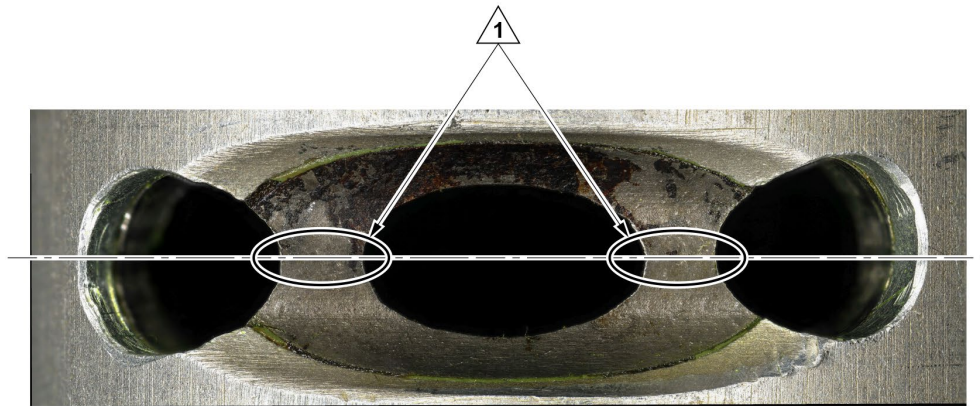

DETAIL A

**NOTE**

 Cracks in the circled areas of the inner sleeve inboard of the stop-drilled holes are not cause for rejection.

22568\_003

**Figure 3 (Sheet 2 of 2) – Stop-Drilled Holes and Inner Sleeve**

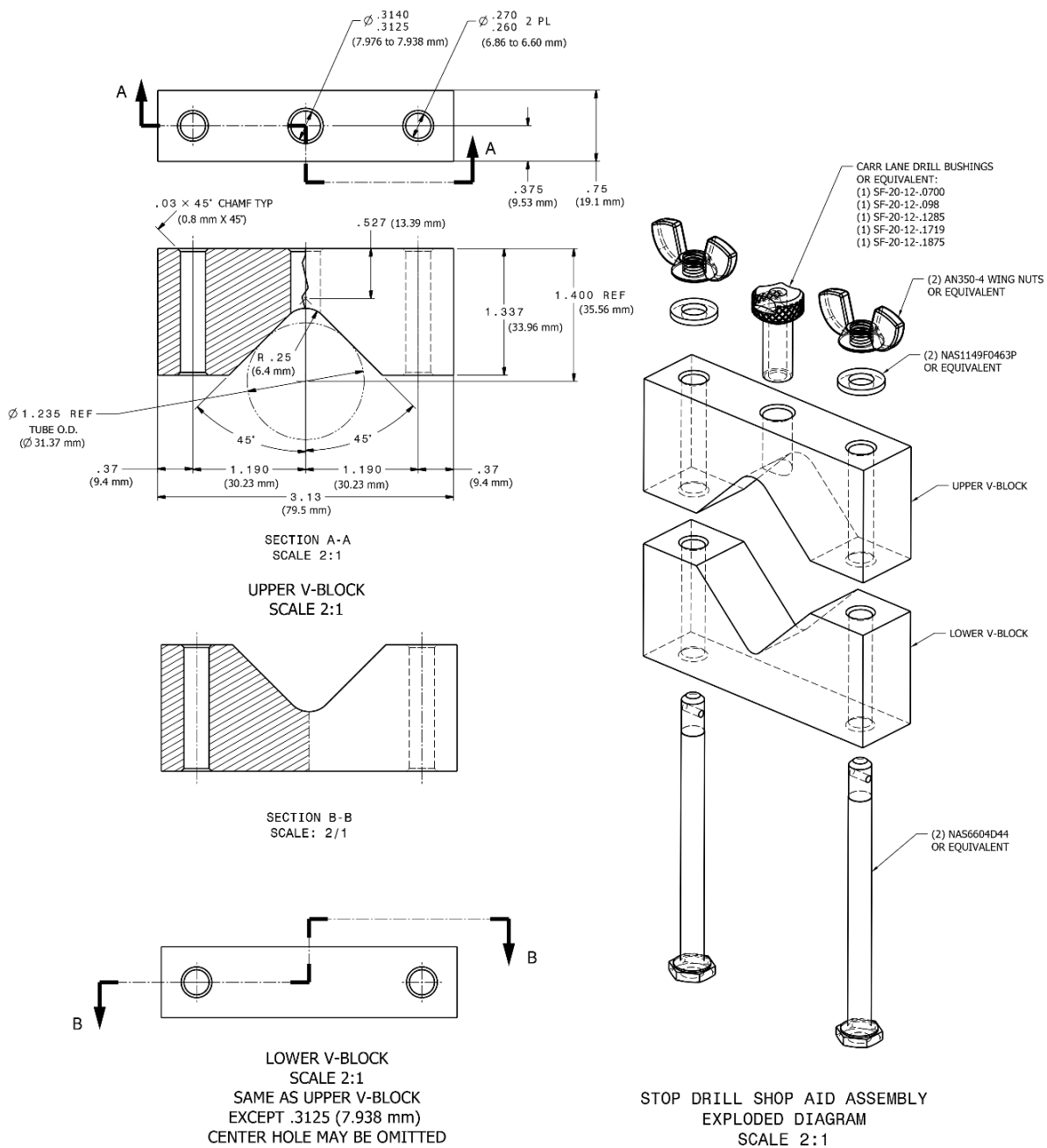

NOTES:

1. ALL DIMENSIONS IN INCHES. MILLIMETERS IN PARENTHESES.
2. V-BLOCK MATERIAL IS OPTIONAL. METALS, PLASTICS, OR 3D PRINTED PLASTICS ARE ACCEPTABLE.
3. BREAK ALL SHARP EDGES WITH .015 (0.38 mm) RADIUS OR .015 (0.38 mm) X 40-50 DEGREE CHAMFER.
4. TOLERANCES ON DECIMALS (INCHES):  
 .XXX ±.010 (0.25 mm)  
 .XX ±.03 (0.8 mm)  
 .X ±.1 (3 mm)  
 TOLERANCE ON ANGLES ±1/2°
5. LOCK SCREW (NOT SHOWN) TO SECURE BUSHING IS OPTIONAL.

23503\_002

Figure 4 – Drilling Guide V-Blocks (Workaid)

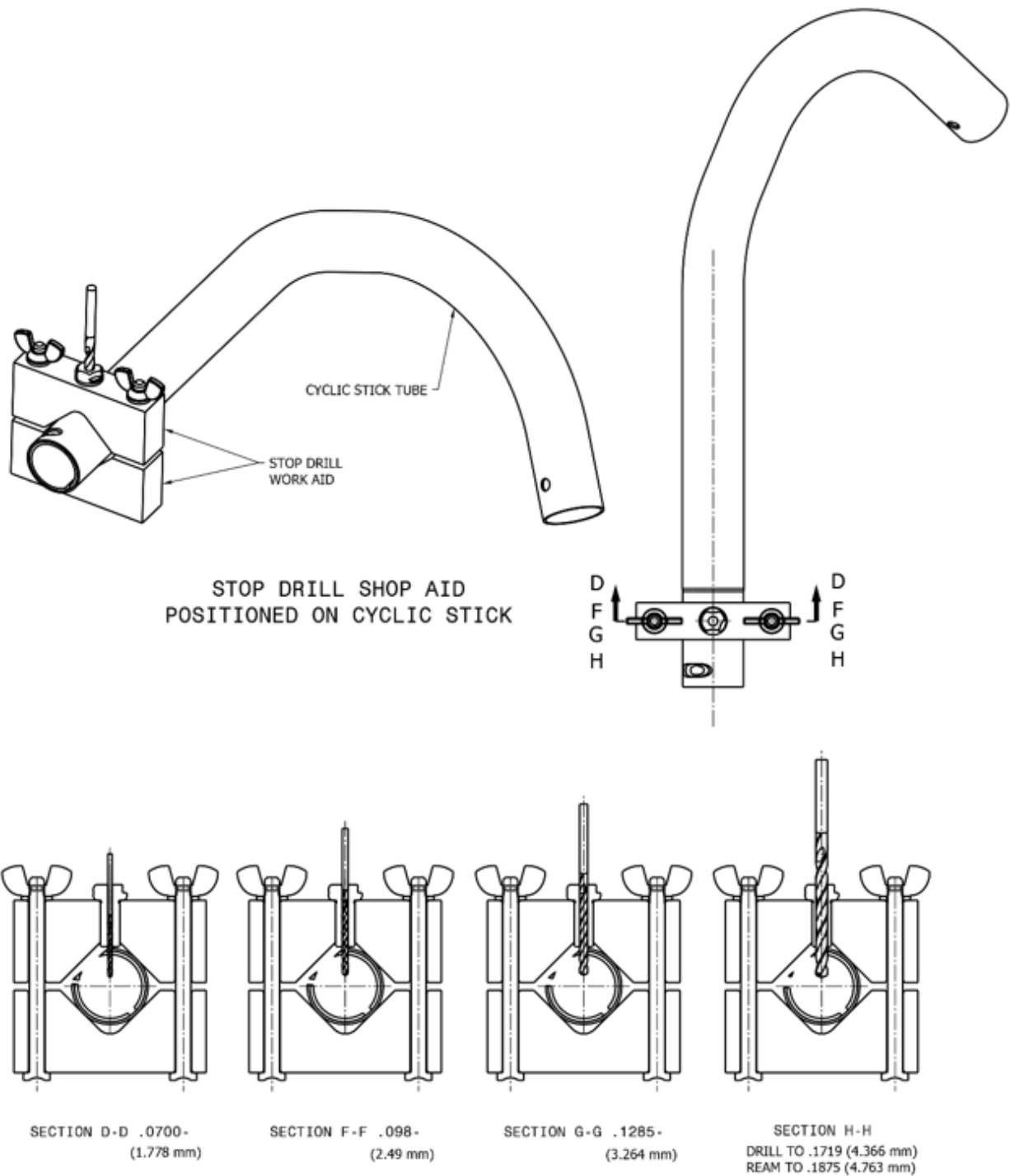

**Figure 5 – Cyclic Stick Tube with Workaid Installed**