

## NOTICE

This revision updates the front matter and Chapter 4. It incorporates new main rotor blade part numbers and associated retirement life.

Please incorporate the attached pages into the existing Maintenance Manual in accordance with the revised Log of Pages (attached).

Bell Helicopter would also like to thank its Customers for providing us with Customer Feedback information. This information is very much appreciated and allows us to improve the quality of our manuals with each revision.

**Bell Helicopter**

A Textron Company

POST OFFICE BOX 482 • FORT WORTH, TEXAS 76101

**27 AUGUST 1992**  
**REVISION 11 — 25 SEPTEMBER 2009**



# **Bell** MODEL **206L3**



## **MAINTENANCE MANUAL**

### **VOLUME 1**

## **GENERAL INFORMATION**

#### **NOTICE**

The instructions set forth in this manual, as supplemented or modified by Alert Service Bulletins (ASB) or other directions issued by Bell Helicopter Textron Inc. and Airworthiness Directives (AD) issued by the applicable regulatory agencies, shall be strictly followed.

Maintenance Manual also applicable to 206L3+ helicopters (Increased Gross Weight kit 206-706-530 installed per BHT-206-SI-2052).

COPYRIGHT NOTICE  
COPYRIGHT 2009  
BELL © HELICOPTER TEXTRON INC.  
AND BELL HELICOPTER TEXTRON  
CANADA LTD.  
ALL RIGHTS RESERVED

**Bell** helicopter

A Textron Company

POST OFFICE BOX 482 • FORT WORTH, TEXAS 76101

**27 AUGUST 1992**  
**REVISION 11 — 25 SEPTEMBER 2009**

### **PROPRIETARY RIGHTS NOTICE**

These data are proprietary to Bell Helicopter Textron Inc. Disclosure, reproduction, or use of these data for any purpose other than helicopter operation or maintenance is forbidden without prior written authorization from Bell Helicopter Textron Inc.

### **DESTINATION CONTROL STATEMENT**

These commodities, technology, or software were exported from the United States in accordance with the Export Administration Regulations (EAR). Diversion contrary to U.S. law prohibited. The data contained in this manual are classified as ECCN EAR99.

Additional copies of this publication may be obtained by contacting:  
Commercial Publication Distribution Center  
Bell Helicopter Textron Inc.  
P. O. Box 482  
Fort Worth, Texas 76101-0482



## LOG OF PAGES (CONT)

Page No.	Rev No.	Page No.	Rev No.	Page No.	Rev No.
Chapter 11		Chapter 28		17.....	10
1/2.....	10	1 – 2 .....	0	18 – 19.....	0
3 – 16.....	10	3/4.....	0	20 – 21.....	10
Chapter 12		5 – 22 .....	0	22 – 30.....	0
1 – 2 .....	6	23 .....	1	31 – 32.....	10
3/4.....	6	24 – 31 .....	0	33 – 34.....	0
5 .....	10	32 – 33 .....	1	35.....	10
6 .....	6	34 – 44 .....	0	36 – 64.....	0
7/8.....	6	45/46.....	0	65/66.....	0
9 .....	6	Chapter 29		Chapter 53	
10 – 12 .....	10	1 – 5 .....	10	1 – 4.....	6
13 – 14 .....	6	6 .....	0	5/6 .....	6
15/16.....	10	7 – 10 .....	10	7 – 14.....	6
17 – 19 .....	10	10A – 10B.....	10	15/16 .....	10
20 – 21 .....	6	11 .....	0	17 – 22.....	6
22 – 23 .....	10	12 – 13 .....	10	23/24 .....	6
24 .....	6	14 – 18 .....	6	<b>VOLUME 6</b>	
25 .....	10	19 – 20 .....	10	Cover.....	10
26 .....	6	20A/20B.....	10	Title .....	10
27 – 28 .....	10	21 – 22 .....	6	PN .....	10
29/30.....	6	23 .....	10	Chapter 62	
31 – 43 .....	6	24 .....	6	1.....	0
44 .....	10	<b>VOLUME 5</b>		2.....	10
<b>VOLUME 3</b>		Cover .....	10	3 – 16.....	0
Cover .....	10	Title .....	10	17.....	10
Title.....	10	PN.....	10	18 – 21.....	0
PN.....	10	Chapter 30		22.....	10
Chapter 21		1/2.....	0	22A/22B.....	10
1/2.....	0	3/4.....	10	23.....	10
3 – 10 .....	0	Chapter 32		24 – 30.....	0
Chapter 25		1/2.....	6	30A/30B.....	10
1 – 2 .....	0	3 – 6 .....	6	31.....	10
3/4.....	0	6A – 6B .....	6	32 – 49.....	0
5 – 44 .....	0	6C/6D .....	6	50.....	10
Chapter 26		7 .....	6	51 – 58.....	0
1/2.....	0	8 – 12 .....	0	59/60.....	10
3 – 4 .....	0	13/14.....	0	Chapter 63	
<b>VOLUME 4</b>		Chapter 52		1 – 4.....	10
Cover .....	10	1 – 6 .....	0	4A/4B.....	10
Title.....	10	7 .....	10	5 – 7.....	10
PN.....	10	8 – 11 .....	0	8.....	0
		12 .....	10	9 – 11.....	10
		13 – 16 .....	0	12 – 14.....	0
				15 – 18.....	10
				18A – 18D .....	10

**CHAPTER 4 — AIRWORTHINESS LIMITATIONS SCHEDULE**

**TABLE OF CONTENTS**

Paragraph Number	Title	Chapter/Section Number	Page Number
<b>AIRWORTHINESS LIMITATIONS SCHEDULE</b>			
4-1	Airworthiness Limitations Schedule. ....	4-00-00	5

**FIGURES**

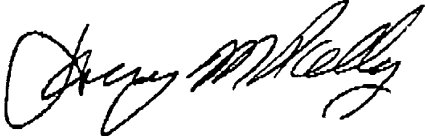
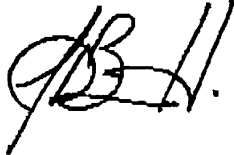

Figure Number	Title	Page Number
4-1	Tailboom Upper Left Attachment Fitting (P/N 206-032-409-001) — Recurring 100-Hour Inspection .....	12



**TABLES**

Table Number	Title	Page Number
4-1	Airworthiness Limitations Schedule .....	6
4-2	Inspection Limitations Schedule .....	11

The Airworthiness Limitations Schedule is approved by the Minister and specifies the maintenance required by any applicable airworthiness or operational rules unless an alternative program has been approved by the Minister.

  
 \_\_\_\_\_  
 Chief Engineering  
 Aircraft Certification  
 Transport Canada

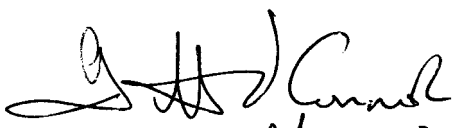
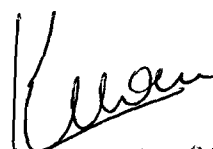
REVISION NO.	DATE OF SIGNATURE	APPROVAL SIGNATURE
Basic Manual	N/A	N/A
Reissue	N/A	N/A
Reissue	27 August 1992	
Rev. 1	N/A	N/A
Rev. 2	N/A	N/A
Rev. 3	N/A	N/A
Rev. 4	09 December 2002	
Rev. 5	22 December 2003	
Rev. 6	N/A	N/A
Rev. 7	30 October 2007	

REVISION NO.	DATE OF SIGNATURE	APPROVAL SIGNATURE
Rev. 8	20 August 2008	 J. H. Conrad A/AARD 20.08.08
Rev. 9	26 May 2009	 K. Green 26-05-2009
Rev. 10	N/A	N/A
Rev. 11	25 SEP 2009	 K. Green 25-SEP-2009



## AIRWORTHINESS LIMITATIONS SCHEDULE

### 4-1. AIRWORTHINESS LIMITATIONS SCHEDULE

Refer to the engine manufacturer's publications for the airworthiness limitations of the power plant components.

#### WARNING

ALL REPAIR AND OVERHAUL PROCEDURE LIVES PUBLISHED BY BELL HELICOPTER TEXTRON, INCLUDING COMPONENT RETIREMENT LIFE, ARE BASED SOLELY ON THE USE OF BELL APPROVED PARTS AND PROCESSES. IF PARTS OR PROCESSES DEVELOPED OR APPROVED BY PARTIES OTHER THAN BELL HELICOPTER ARE USED, THEN THE DATA PUBLISHED OR OTHERWISE SUPPLIED BY BELL HELICOPTER ARE NOT APPLICABLE. THE USER IS WARNED TO NOT RELY ON BELL HELICOPTER DATA FOR PARTS AND PROCESSES NOT APPROVED BY BELL HELICOPTER. ALL APPLICABLE INSPECTIONS AND REPAIR METHODS MUST BE OBTAINED FROM THE SUPPLIER OF THE PARTS OR PROCESSES NOT APPROVED BY BELL HELICOPTER. BELL HELICOPTER IS NOT RESPONSIBLE FOR PARTS OR PROCESSES OTHER THAN THOSE WHICH IT HAS ITSELF DEVELOPED OR APPROVED.

The mandatory Airworthiness Limitations Schedule ([Table 4-1](#)) summarizes the mandatory maximum life, in hours, years or by Retirement Index Number (RIN) of components with a limited airworthiness life. Parts that are not on the schedule have an unlimited airworthiness life. The Inspection Limitations Schedule ([Table 4-2](#)) summarizes the mandatory inspection interval in hours.

#### NOTE

The airworthiness life for any part number contained in this schedule applies to all the successive dash numbers for that component unless otherwise specified.

#### WARNING

SOME PARTS ARE INSTALLED AS ORIGINAL EQUIPMENT ON BOTH MILITARY AND COMMERCIAL HELICOPTERS AND MAY HAVE A LOWER AIRWORTHINESS LIFE AND/OR OVERHAUL SCHEDULE WHEN USED ON A MILITARY HELICOPTER. IN ADDITION, CIRCUMSTANCES SURROUNDING THEIR USE MAY CALL FOR OPERATION OF THE MILITARY HELICOPTER OUTSIDE OF THE APPROVED COMMERCIAL FLIGHT ENVELOPE. CONSEQUENTLY, PARTS THAT HAVE BEEN USED ON MILITARY HELICOPTERS SHOULD NOT BE USED ON COMMERCIAL HELICOPTERS.

#### CAUTION

AIRWORTHINESS LIFE OF SOME KIT COMPONENTS IS NOT COVERED IN THIS SCHEDULE. REFER TO APPLICABLE SERVICE INSTRUCTION (SI) OR MAINTENANCE MANUAL SUPPLEMENT (MMS) FOR KIT COMPONENT SCHEDULES.

#### NOTE

The retirement life given, or the failure to give a retirement life to a component, does not constitute a warranty of any kind. The only warranty applicable to the helicopter or any component is the warranty included in the Purchase Agreement for the helicopter or the component.

The airworthiness lives given to the components and assemblies are determined by experience, tests, and the judgment of Bell Helicopter engineers. The lives

cannot be changed without the approval of the Minister of Transport Canada.

does not allow them to be returned for service. Refer to FAA Advisory Circular 21-38 for guidance on the disposal of unsalvageable aircraft parts and materials.

Prior to disposing of unsalvageable aircraft parts and materials, caution should be exercised to ensure that the parts and material are disposed of in a manner that

**Table 4-1. Airworthiness Limitations Schedule**





















COMPONENT	PART NUMBER 	RETIREMENT LIFE (YEARS/HOURS/RIN)
<b>MAIN ROTOR HUB AND BLADES</b>		
Main Rotor Trunnion	206-011-120-103	  24,000 RIN
Pin, Strap Retention	206-011-125-001	1200 hours
Main Rotor Grip	206-011-132-009	 4800 hours
Main Rotor Grip	206-011-132-113	4800 hours
Tension Torsion Strap	206-011-147-007	  1200 hours/24 months
Fitting, Strap Retention	206-011-150-101	2400 hours
Fitting, Strap Retention	206-011-150-105	2400 hours
Tension Torsion Strap	206-011-154-103/-107	 1200 hours/24 months
Latch Bolt	206-011-260-101	 1200 hours
Main Rotor Blade	206-015-001-001/-103/-105	  3600 hours
Main Rotor Blade	206-015-001-107/-109/-111/-113/-115/-117/-119/-121	 3600 hours
Main Rotor Blade	206-015-001-125/-127/-129/-131	 2300 hours
<b>SWASHPLATE AND SUPPORT</b>		
Tube, Lower Cyclic	206-001-193-001	4800 hours
Link, Collective Idler	206-010-407-001	4800 hours
Link, Collective Idler	206-010-446-105	  1200 hours
Link, Collective Idler	206-010-446-107	 4800 hours
Support Assembly, Swashplate	206-010-445-105	4800 hours
Support Assembly, Swashplate	206-010-445-113	4800 hours
Support Assembly, Swashplate	206-010-452-109	 4800 hours
Support Assembly, Swashplate	206-010-452-113	4800 hours
Sleeve Assembly, Collective	206-010-454-107	 4800 hours
Sleeve Assembly, Collective	206-010-454-109	4800 hours
Lever, Collective	206-010-447-105	  1200 hours
Lever, Collective	206-010-447-109	 4800 hours
Lever, Collective	206-010-467-001/-105	4800 hours

Table 4-1. Airworthiness Limitations Schedule (Cont)

































COMPONENT	PART NUMBER 	RETIREMENT LIFE (YEARS/HOURS/RIN)
<b>POWER TRAIN</b>		
Duplex Bearing, Tail Rotor Gearbox	206-040-410-003/-005/-101	3000 hours
Mast, Main Rotor	206-040-535-101	  5000 hours/44,000 RIN
Mast, Main Rotor	206-040-535-105	   5000 hours/44,000 RIN
Sun Gear	206-040-662-101	
Driveshaft, Main	206-340-300-101	  5000 hours
Clutch, Freewheel Assembly	CL41742-1	3000 hours
Clutch, Freewheel Assembly	CL42250-1	3000 hours
<b>TAIL ROTOR HUB AND BLADES</b>		
Yoke, Tail Rotor	206-011-819-101	 5000 hours
Yoke, Tail Rotor	206-011-819-105/-109	5000 hours
Yoke, Tail Rotor	406-012-102-107/-113	 5000 hours
Blade, Tail Rotor	206-016-201-001/-107	 2400 hours
Blade, Tail Rotor	206-016-201-113	  2400 hours
Blade, Tail Rotor	206-016-201-127/-131	    2500 hours
Blade, Tail Rotor	400-016-100-109/-113	 5000 hours
<b>AIRFRAME</b>		
Horizontal Stabilizer	206-023-119-167	
<b>MISCELLANEOUS KITS</b>		
Crosstube, Landing Gear, High Gear	206-053-109-ALL	
Crosstube, Landing Gear, Standard	206-053-119-ALL	
Crosstube, Landing Gear, Fixed Floats	206-050-169-011/-013	
Crosstube, Landing Gear, Fixed Floats	206-053-211-103	
Reservoir, Emergency Floats	1269556-3/-4	 15 years
Reservoir, Emergency Floats	1271226	 15 years
Reservoir, Emergency Floats	206-073-848-101/-107/-113	 15 years
Reservoir, Emergency Floats	206-073-848-121	 15 years
Squib, Emergency Floats	94455	

Table 4-1. Airworthiness Limitations Schedule (Cont)

COMPONENT	PART NUMBER 	RETIREMENT LIFE (YEARS/HOURS/RIN)
<b>MISCELLANEOUS KITS (CONT)</b>		
Squib, Emergency Floats	29022968	
Cable Cutter Assembly, Hoist	Y-1265-11-1	
<b>POWER PLANT</b>		
Turboshaft Engine	250-C30P	Refer to Rolls Royce 250-C30P Operation and Maintenance Manual, 14W2

**NOTES:**















-  Airworthiness limitation for part number listed applies to all successive dash numbers for that component unless otherwise specified.
-  RESERVED.
-  RESERVED.
-  RESERVED.
-  RESERVED.
-  RESERVED.
-  RESERVED.
-  Selected serial numbers of main rotor grips 206-011-132-009 will have been removed from service upon reaching 1200 hours in service. Refer to BHT ASB 206L-80-15, dated 29 July 1980 for list of serial numbers affected.
-  Selected serial numbers of main rotor mast 206-040-535-105 will have been returned to Bell Helicopter for metallurgical evaluation no later than 31 May 1987. Affected masts inspected at BHT and found to be acceptable have the suffix "U" added to the serial number. Refer to BHT ASB 206L-87-44, dated 23 April 1987 for list of serial numbers affected.
-  Selected serial numbers of tail rotor yoke 206-011-819-101 will have been returned to Bell Helicopter for inspection and rework no later than 1 April 1988. Refer to BHT ASB 206L-88-51, dated 23 April 1987 for list of serial numbers affected.
-  Main rotor hub tension torsion straps 206-011-147 and 206-011-154 have airworthiness lives of 1200 hours or 24 months, whichever occurs first. The calendar life of 24 months starts when new straps are installed in a main rotor hub and blade assembly and are subjected to rotation on the aircraft. Refer to BHT ASB 206L-80-12, dated 2 June 1980.
-  Selected serial numbers of tension torsion straps 206-011-147-007 must be removed from service. Refer to BHT ASB 206L-89-60, dated 29 August 1989 for list of serial numbers affected.
-  Selected serial numbers of main rotor blades 206-015-001-001/-103/-105 must be removed from service. Refer to BHT ASB 206L-89-64 Revision A, dated 29 November 1989 for list of serial numbers affected.
-  Selected serial numbers of sun gear 206-040-662-101 must be removed from service. Refer to BHT ASB 206L-90-69 Revision A, dated 15 January 1991 for list of serial numbers affected.
-  Selected serial numbers of tail rotor blades 206-016-201-113/-127 must be removed from service. Refer to BHT ASB 206L-90-70, dated 27 June 1990 for list of serial numbers affected.

Table 4-1. Airworthiness Limitations Schedule

**NOTES (CONT):**

- △<sub>16</sub> Selected serial numbers of tail rotor blade 206-016-201-127 will have been returned to Bell Helicopter for evaluation no later than 30 September 1990. Affected blades inspected at BHT and found to be acceptable have the suffix "M" added to the serial number. Refer to BHT ASB 206L-90-71 Revision A, dated 31 October 1990 for list of serial numbers affected.
- △<sub>17</sub> Selected serial numbers of main rotor latch bolt 206-011-260-101 must be removed from service. Refer to BHT ASB 206L-92-86, dated 3 December 1992 for list of serial numbers affected.
- △<sub>18</sub> Landing gear crosstubes 206-053-109-ALL and 206-053-119-ALL (all dash numbers) will have been removed from service no later than 30 September 1994. Refer to BHT ASB 206L-94-93, dated 11 April 1994.
- △<sub>19</sub> Landing gear crosstubes 206-053-169-011/-013 will have been removed from service no later than 31 January 1995. Refer to BHT ASB 206L-94-97, dated 17 August 1994.
- △<sub>20</sub> RESERVED.
- △<sub>21</sub> Each component with a retirement life sensitive to torque events will be assigned a maximum Retirement Index Number (RIN). This RIN corresponds to maximum allowed fatigue damage resulting from lifts and takeoffs. A TORQUE EVENT is defined as a takeoff (one takeoff plus subsequent landing = one RIN) or a lift (internal or external). For example, if an operator performs six (6) takeoffs and ten (10) slingloads, this would total 16 torque events; (6 takeoffs = 6 events, 10 slingloads = 10 events, 6 + 10 = 16 torque events total).
- Pilots are to record total number of torque events for each flight. This allows maintenance personnel to convert torque events to RIN by applying the appropriate RIN Adjustment Factor. Refer to BHT ASB 206L-94-99, Revision B, dated 10 August 2001. A new component will begin with an accumulated RIN of zero, that will be increased as lifts and takeoffs are performed. Operator will record number of lifts and takeoffs (torque events), and increase accumulated RIN accordingly. When maximum RIN is reached or retirement flight hours, whichever occurs first, component will be removed from service.
- △<sub>22</sub> The retirement life of trunnion 206-011-120-103 is based solely on RIN. Retire trunnion when RIN = 24,000. For each takeoff/lift, add one (1) RIN if the trunnion is installed on 206L, 206L-1 or 206L-3 (includes 206L-3 with Increased Power Operation kit installed per Service Instruction 206-SI-2039) and two (2) RIN if the trunnion is installed on a 206L-4. Refer to BHT ASB 206L-94-99 Revision B, dated 10 August 2001.
- △<sub>23</sub> Retire mast 206-040-535-001/-005/-101/-105 when RIN = 44,000. For each takeoff/lift, add one (1) RIN if the mast is installed on 206L, 206L-1 or 206L-3 (includes 206L-3 with Increased Power Operation kit installed per Service Instruction 206-SI-2039) and two (2) RIN if the mast is installed on a 206L-4. Refer to BHT ASB 206L-94-99 Revision B, dated 10 August 2001.
- △<sub>24</sub> Collective idler link 206-010-446-105, serial numbers A-1 through A-27, inclusively, and serial numbers RE-238 through and including RE-270 will be retired from service at 1200 hours service time. Refer to BHT ASB 206-98-110, dated 6 May 1998.
- △<sub>25</sub> Collective lever 206-010-447-105, serial numbers A-1 through A-22, inclusively, will be retired from service at 1200 hours service time. Refer to BHT ASB 206L-98-110, dated 6 May 1998.

**Table 4-1. Airworthiness Limitations Schedule (Cont)****NOTES (CONT):**

- 26 Swashplate support 206-010-452-001/-005/-109 must be inspected every 50 hours after the swashplate support has accumulated 1500 hours in service. Refer to BHT ASB 206L-93-89 Revision B, dated 4 April 1994.
- 27 Aft crosstube assembly 206-053-211-103 has an airworthiness life of 33,000 landings. Refer to BHT ASB 206L-94-97, dated 17 August 1994.
- 28 Reservoir per DOT-3HT specification and Exemption Letter DOT-E-7218. This reservoir is a detail part of reservoir assembly P/N 206-073-848-101/-107/-113. Life starts from date of manufacture.
- 29 Reservoir per DOT-3HT specification and Exemption Letter DOT-E-8162. This reservoir is a detail part of reservoir assembly P/N 206-073-848-121. Life starts from date of manufacture.
- 30 Tail rotor blade 206-016-201-127 and subsequent, retirement life increased to 2500 hours. Refer to BHT TB 206L-89-147, dated 2 June 1989.
- 31 Main rotor blade 206-015-001-ALL. It is permissible to use any main rotor blade (mix and match) on helicopter model 206L, 206L-1, 206L-3, 206L-4, provided that all conditions are met. Refer to BHT TB 206L-87-142, dated 1 October 1987, and information letter IL 206L-00-68 Revision A or subsequent.
- 32 Tail rotor blade 206-016-201-ALL. It is permissible to use any tail rotor blade on helicopter model 206L, 206L-1, 206L-3, 206L-4 provided that all conditions are met. Refer to BHT TB 206L-94-167 Revision A, dated 1 May 1995.
- 33 Part of squib assembly 30908. Retire squib no later than 15 years after date of manufacturing. Dispose of time expired squib in accordance with local regulations.
- 34 Part of squib assembly 29022971 and approved alternate for squib 30908. Retire squib no later than 15 years after date of manufacturing. Dispose of time expired squib in accordance with local regulations.
- 35 Storage life of cutter assembly Y-1265-11-1, in original sealed container, is set at 60 months. Service life is 36 months from the time the cutter assembly is removed from the original sealed container. The 36-month service life must be contained within the 60-month storage life. Dispose of time expired squib in accordance with local regulations.
- Example 1 – Cutter assembly stored for 24 months:  $60 - 24 = 36$ -month service life.  
 Example 2 – Cutter assembly stored for 48 months:  $60 - 48 = 12$ -month service life.  
 Example 3 – Cutter assembly stored for 1 month:  $60 - 1 = 59$  months, reduced to 36 months maximum service life.
- 36 This reservoir assembly includes reservoir P/N 1269556-3 or -4.
- 37 This reservoir assembly includes reservoir P/N 1271226.
- 38 Affected horizontal stabilizer 206-023-119-167 must be removed from service no later than 30 September 2008. Refer to ASB 206L-06-141 for list of horizontal stabilizer serial numbers affected. Applicable horizontal stabilizers must be inspected every 600 hours or annually until replaced. Refer to ASB 206L-06-141 for inspection details.
- 39 Applicable to helicopters with Increased Gross Weight kit 206-706-530 installed per BHT-206-SI-2052.
- 40 The retirement life also applies to main driveshaft 206-340-300-105 and 206-340-300-105M. Refer to ASB 206L4-01-123, Revision A.

**Table 4-2. Inspection Limitations Schedule**

COMPONENT	PART NUMBER ①	INSPECTION INTERVAL (HOURS OPERATION TIME)
Tailboom Upper Left Attachment Fitting	206-032-409-001	② 100 Hours

**NOTES:**

- ① Inspection limitation for the part number listed applies to all successive dash numbers for that component, unless otherwise specified.
- ② You must do an inspection of the tailboom upper left attachment fitting P/N 206-032-409-001 every 100 flight hours. Refer to BHT ASB 206L-09-158 for a listing of affected tailbooms. Refer to [Figure 4-1](#) for inspection details.

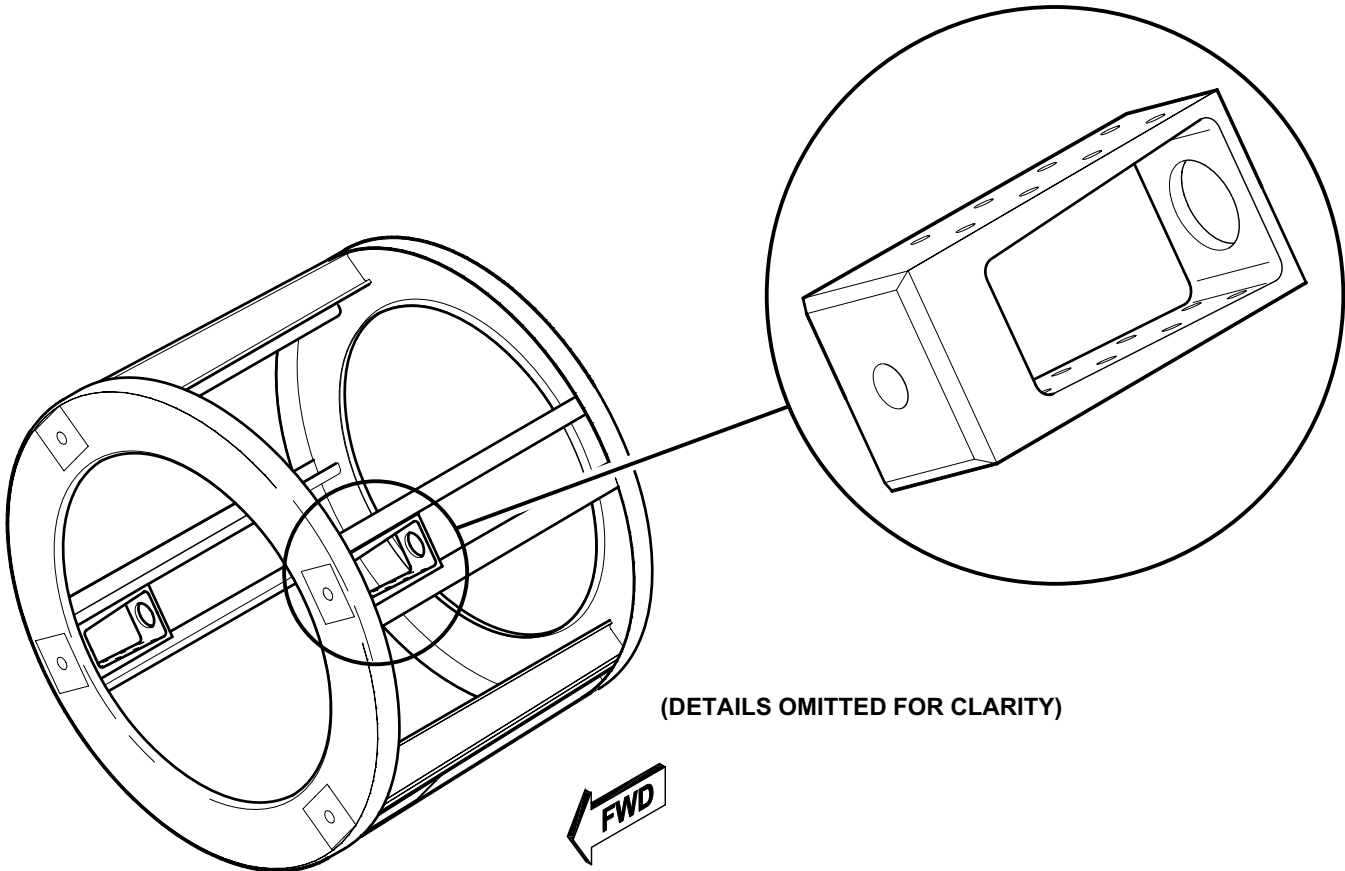
**INSPECTION PROCEDURE:**

1. Inspect upper left attachment fitting for cracks, mechanical damage, corrosion damage, loose rivets, and general condition.
2. Refer to ASB 206L-09-158 for wear, damage, and repair limits.
3. Repair fitting in accordance with ASB 206L-09-158.
4. Replace cracked or damaged fitting or loose rivets in accordance with ASB 206L-09-158.
5. If a crack is found, contact Product Support Engineering with details as follows:

Bell Helicopter Textron  
 Product Support Engineering  
 Light Helicopters group  
 Tel: 1-800-243-6407 (Continental USA and Canada)  
 1-800-363-8023 (Continental USA)  
 1-800-361-9305 (Within Canada)  
 1-450-437-2862 (All other areas - Call collect)  
 Fax: 450-433-0272  
 Email: [pselight@bellhelicopter.textron.com](mailto:pselight@bellhelicopter.textron.com)

**Figure 4-1. Tailboom Upper Left Attachment Fitting (P/N 206-032-409-001)**  
**— Recurring 100-Hour Inspection**

206LS MM 04 0001