

ALERT SERVICE BULLETIN

Bell Helicopter **TEXTRON**

A Subsidiary of Textron Inc.

NO. 205A1-01-82

DATE 03-30-01

PAGE 1 of 8

DATE
REV

MODEL AFFECTED: 205A-1

SUBJECT: CHIP DETECTOR ASSEMBLY, TEDECO B3703

HELICOPTERS AFFECTED: All Model 205A-1 helicopters.

COMPLIANCE: No later than September 30, 2001.

DESCRIPTION:

Bell Helicopter has become aware of chip detector model TEDECO B3703 that could possibly have poor or no continuity between the insert and the chip detector housing. This could result in no chip indication when the chip detector has been bridged by metal particles. EATON has issued the following Alert Service Bulletin to perform a continuity test and temporary repair of affected chip detectors.

APPROVAL:

The engineering design aspects of this bulletin are FAA/DER approved.

MANPOWER:

Approximately 2.0 man-hours are required to complete this bulletin. Man-hours are based on hands-on time, and may vary with personnel and facilities available.

7851 55192 REV 1198

AN APPROPRIATE ENTRY SHOULD BE MADE IN THE AIRCRAFT LOG BOOK UPON ACCOMPLISHMENT
IF OWNERSHIP OF AIRCRAFT HAS CHANGED PLEASE FORWARD TO NEW OWNER

MATERIAL:

Required Material:

None required

Consumable Material:

None required

SPECIAL TOOLS:

None required

WEIGHT AND BALANCE:

Not affected

ELECTRICAL LOAD DATA:

Not affected

REFERENCES:

BHT-205A1-IPB Illustrated Parts Breakdown
BHT-205A1-MM Maintenance Manual

ACCOMPLISHMENT INSTRUCTIONS:

1-Refer to attach copy of the EATON Alert Service Bulletin for accomplishment instruction.

Tedeco Products

ALERT SERVICE BULLETIN

Affected Part numbers: Tedeco B3703, B3188B

1. Test Procedure

Units that are not installed in an aircraft should be tested per Procedure A. Units installed in aircraft should be tested per procedure B. These tests will determine if the unit is acceptable by verifying that the resistance between the probe body and the valve body is 5 ohms or less.

Procedure A: (Chip Detectors not installed in an aircraft)

Required Tools:

- a) 28 Volt DC power supply
- b) 700 ohm, 2 watt resistor

1. Connect the chip detector to a 28 Volt DC power supply using a 700 ohm, 2 watt resistor as shown in Figure 1.
2. Measure the voltage between the probe body and the valve body. The voltage drop must be 0.20 volts or less across the unit. If the voltage drop is larger than 0.20 volts, then return the unit to Tedeco (See 3. Part Replacement.)

(A current supply can be used, set to 40 mA, or another voltage can be used with an appropriate series resistor. The resistance is the voltage drop across the unit divided by the current.)

NOTE: Measuring the resistance with a digital ohmmeter or similar low current instrument may not give a reliable reading for this test.

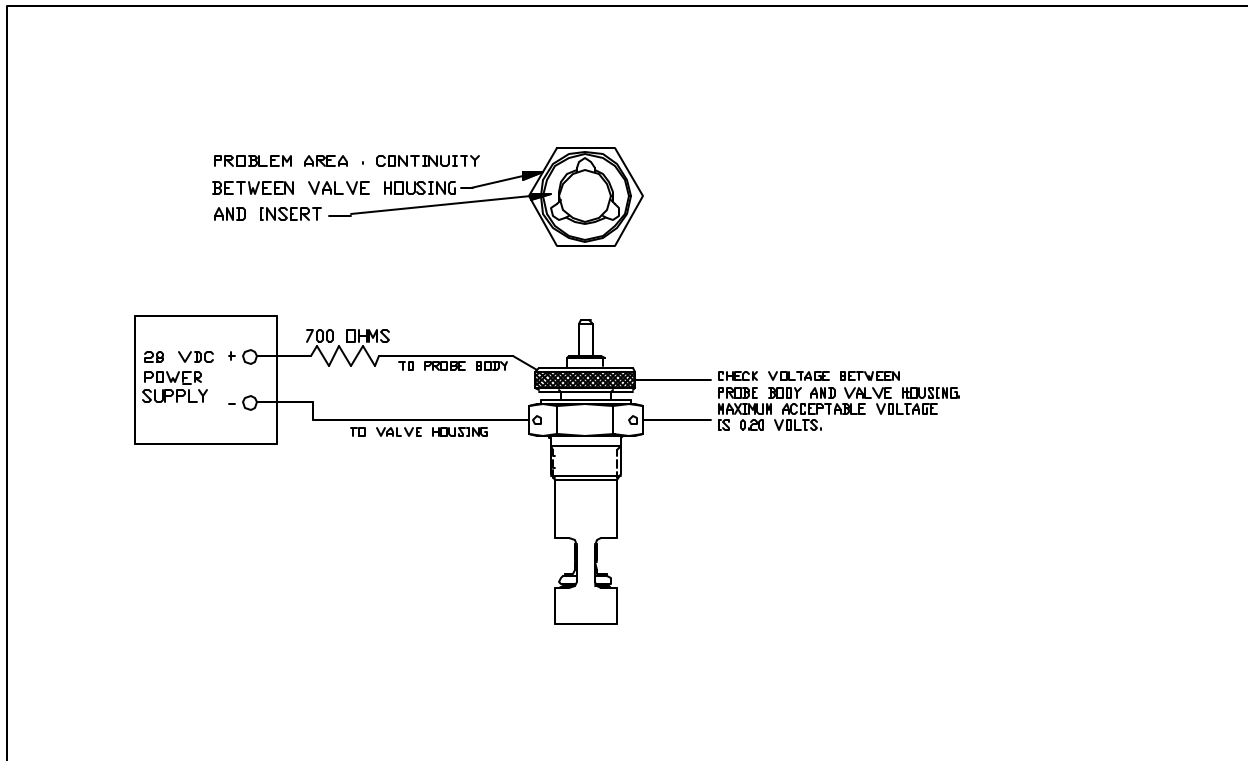

FIGURE 1

Procedure B: (Chip Detectors installed in an aircraft)

Required Tools:

None – This test is performed on the aircraft using aircraft power, wiring, and cockpit displays.

1. Ensure that electrical power is supplied to the chip detector.
2. Remove the chip detector probe from the self-closing valve.
3. Hold the tip of the center stud of the chip detector probe firmly against the steel insert as shown in Figure 2 while checking chip indicator light in cockpit. If the cockpit light illuminates, the unit is acceptable. If the light does not illuminate, then proceed to the next step.

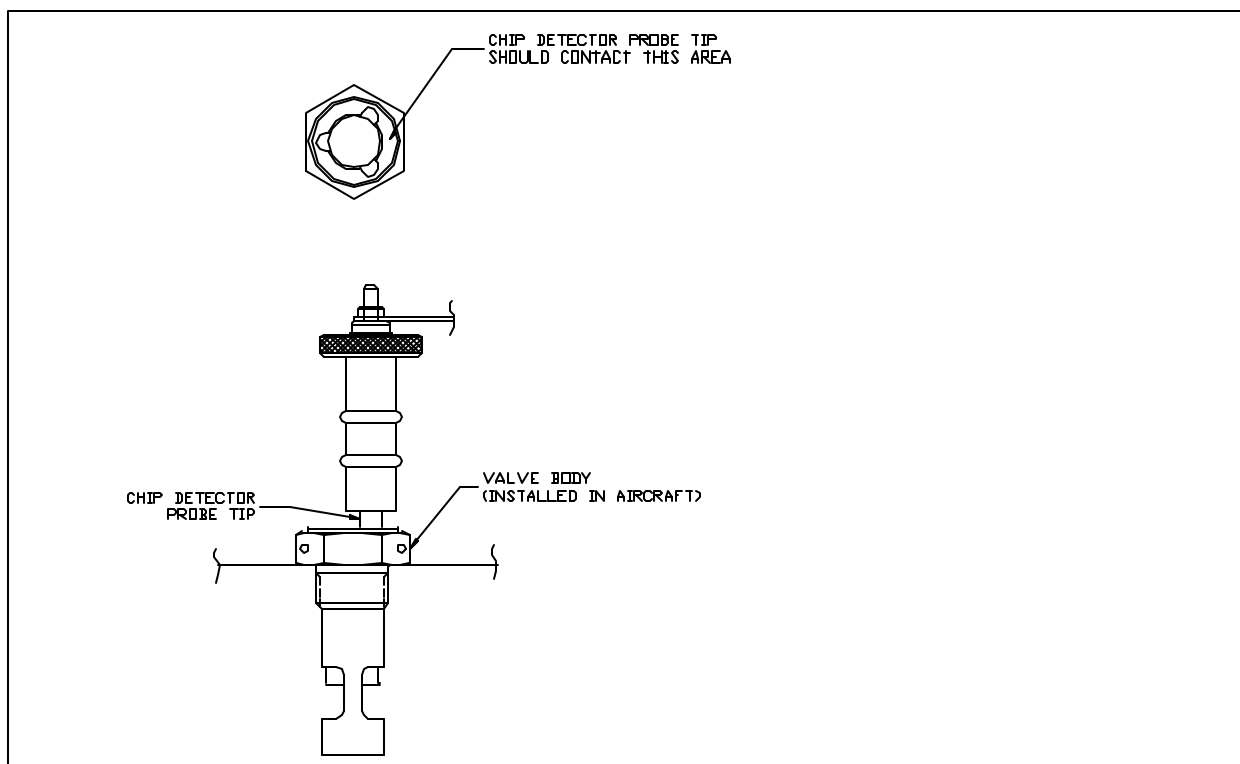

FIGURE 2

4. Hold the tip of the center stud of the chip detector probe firmly against the valve housing as shown in Figure 3 while checking chip indicator light in cockpit. The cockpit light should illuminate. Illumination of the light in this step isolates the electrical discontinuity to the valve insert. Repair the unit per the repair instructions in section 2 of this document.

If the light still does not illuminate during this check of the valve housing, there is an electrical discontinuity somewhere else in the circuit. Check the remaining electrical circuit between chip detector and cockpit indicator light.

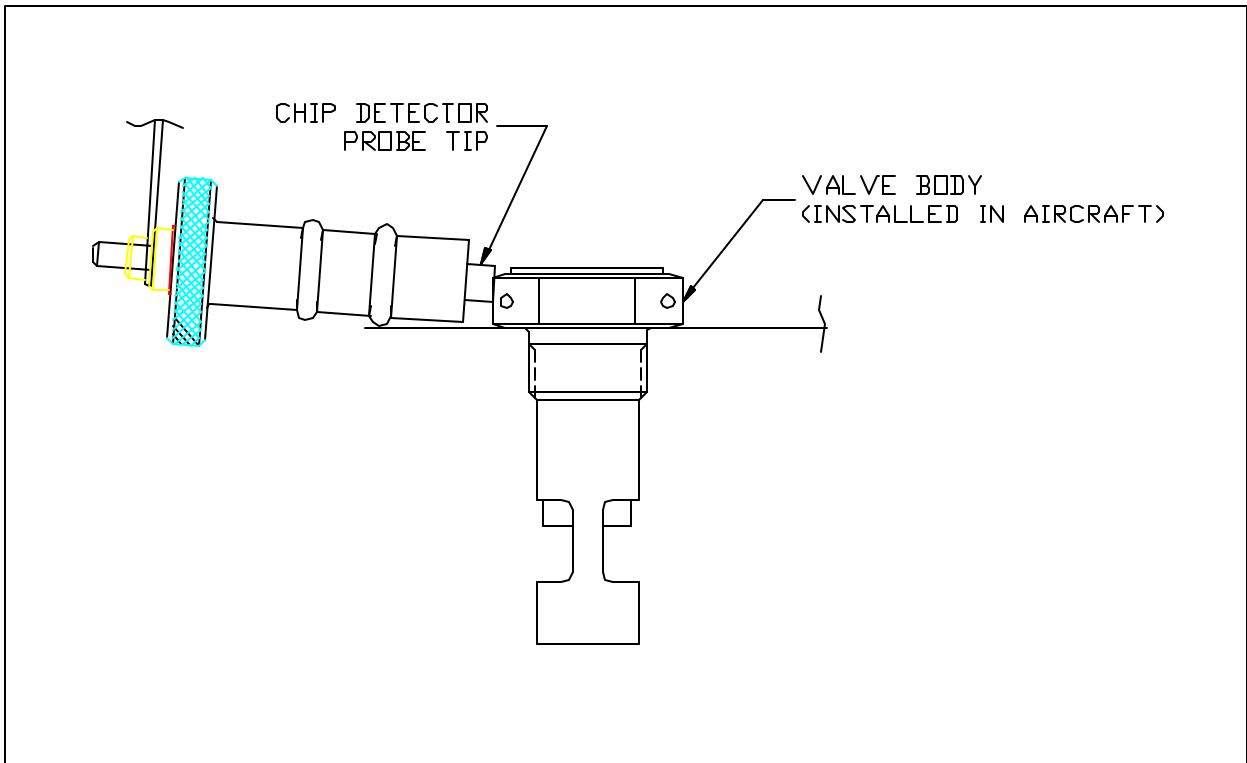

FIGURE 3

2. Repair Instructions

Required Tools:

- a) Lockwire and associated tooling
- b) Ohmmeter

NOTE: Aircraft power to chip detector should be turned off prior to performing this repair.

- 2.1. Install Chip Detector Probe into Valve assembly.
- 2.2. Tightly wrap a piece of lockwire (approx 6 inch length) around the chip detector probe diameter shown two full times. (See Figure 4A.)

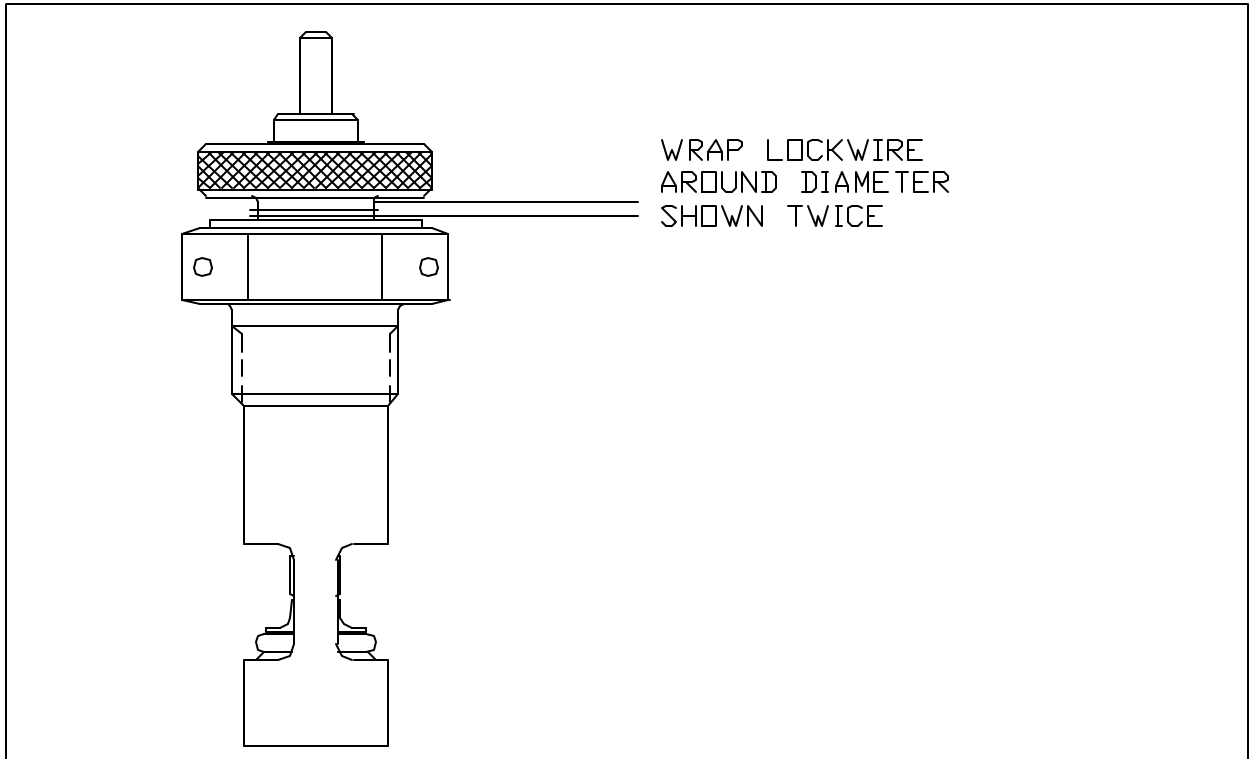

FIGURE 4A

- 2.3. Twist two ends together approximately five times until twisted section reaches nearest free lockwire hole. Ensure that lockwire is tightly wrapped.
- 2.4. Slide one end of lockwire through the lockwire hole. Continue twisting two ends together to complete the lockwiring. (See Figure 4B.)
- 2.5. Check repair by using an ohmmeter to check resistance between the chip detector probe and the valve housing. Resistance should be 1 ohm maximum. (See Figure 4B.)

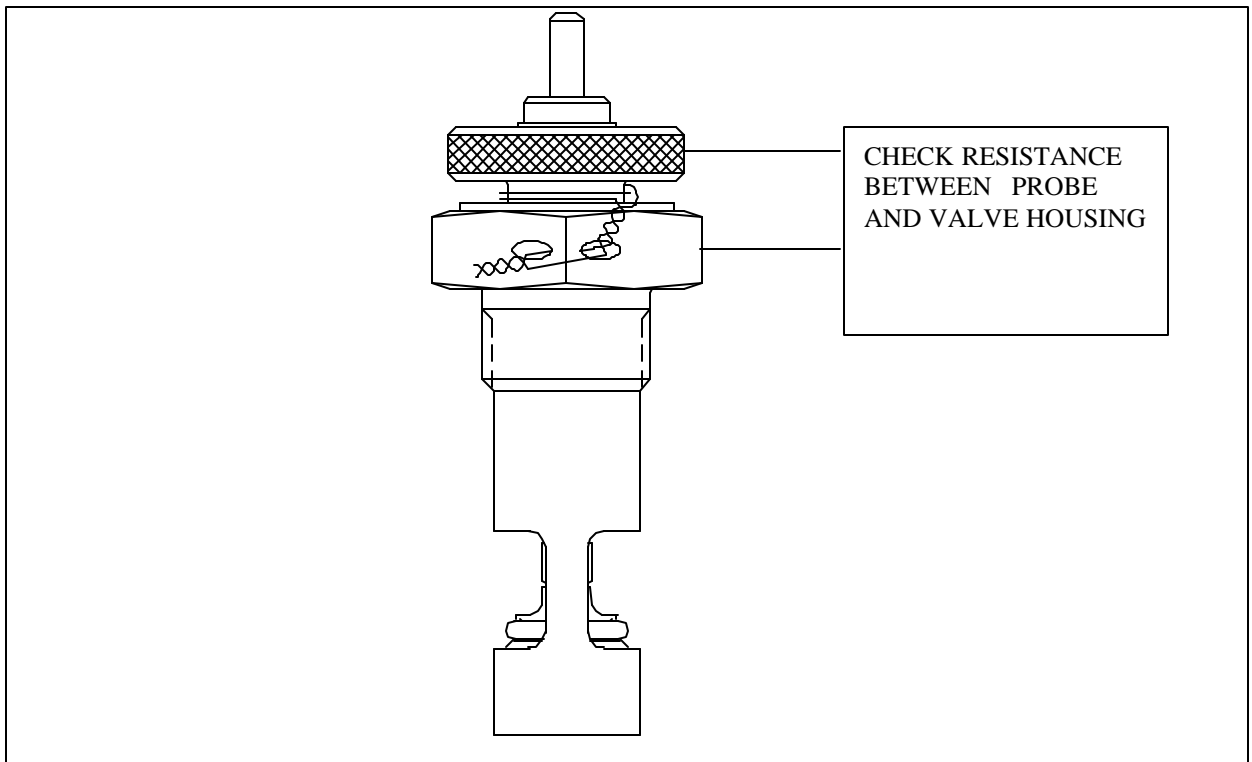

FIGURE 4B

3. Part Replacement

Units that have been repaired should eventually be **reworked or replaced at Tedeco's discretion at no cost** with new production units **by Eaton Aerospace, Tedeco Products Division**. Repaired units can be returned to Eaton Aerospace, Tedeco Products division at the address below:

Eaton Aerospace, Tedeco Products Division
24 East Glenolden Ave.
Glenolden, PA 19036-2198