

ALERT SERVICE BULLETIN
Bell Helicopter **TEXTRON**

A Subsidiary of Textron Inc.

NO. 206L-04-131

DATE Sep 13, 2004

PAGE 1 of 5

DATE

REV

MODEL AFFECTED: 206L-SERIES

SUBJECT: TAIL ROTOR BLADE 206-016-201-131, CHECK AND REMOVAL FROM SERVICE OF.

HELICOPTERS AFFECTED: ALL 206L SERIES helicopters

BLADES AFFECTED Tail rotor blades 206-016-201-131 serial numbers CS-4820 through, and including CS-4845.

COMPLIANCE: Part I: Before the first flight of every day until Part II is completed.

Part II: Within the next 100 flight hours of operation, but no later than January 31, 2005.

DESCRIPTION:

Bell Helicopter has received two reports of de-bonding of the blade root doubler. In both cases this situation was noticed as part of the pre-flight inspection on the affected helicopters. Investigation revealed that inadequate surface preparation on a limited number of blades resulted in poor adherence of the doublers.

Part I of this bulletin requires a daily check of the doubler area to verify integrity of the doubler. The check can be accomplished by the pilot as part of the daily pre-flight check.

Part II of this bulletin imposes the retirement from service of affected blades and constitutes terminating action.

APPROVAL:

The engineering design aspects of this bulletin are Transport Canada approved.

MANPOWER:

Approximately 0.25 man-hours are required to complete Part I of this bulletin. Approximately 4.0 man-hours are required to complete Part II. Man-hours are based on hands-on time, and may vary with personnel and facilities available.

WARRANTY:

Owner / Operators of Bell 206L or 206AB helicopter who comply with the instructions Outlined in this bulletin will be eligible for a special pro-rated warranty credit for Replacement of the 206-016-201-131 T/R Blade. This pro-rated credit will be based on hours used to the life of the blade.

To receive this credit:

- Purchase the required part from a BHT supply source.
- Comply with the instructions contained in this bulletin no later than the applicable hours listed in the "Compliance Section" of the ASB.
- Submit an MMIR to The Bell Warranty Dept. for the affected T/R Blade.

Part I

Owner / Operators that comply with Part I of this bulletin and find a debonding at the root doubler will be eligible for 100% pro-rated credit.

Part II

Owner / Operators that comply with Part II of this ASB will be eligible for the following warranty.

- If the aircraft or Tail Rotor Blade is currently covered by a standard Bell Helicopter commercial warranty at the time of compliance (new aircraft or spare parts) the cost of the replacement blade to comply with Part II of this ASB will be warranted using the standard Bell Helicopter proration table.
- If the aircraft or blade are no longer covered under a standard Bell Helicopter commercial warranty (new aircraft or spare parts) the cost of the replacement blade to comply with Part II of this ASB will be covered at 60% of the standard Bell Helicopter proration table.

MATERIAL:

None required

Consumable Material:

The following material is required to accomplish this bulletin, but may not require ordering, depending on the operator's consumable material stock levels. This material may be obtained through your Bell Helicopter Textron Supply Center.

<u>Part Number</u>	<u>Nomenclature</u>	<u>Quantity</u>	<u>Reference</u>
MILC87936TYI 5GAL	Detergent (1)	As required	C-318

Note:

1. Equivalent aviation approved detergent can be used.

SPECIAL TOOLS:

None required

WEIGHT AND BALANCE:

Not affected

ELECTRICAL LOAD DATA:

Not affected

REFERENCES:

BHT-206L-SERIES-MM Maintenance Manual

PUBLICATIONS AFFECTED:

None affected

ACCOMPLISHMENT INSTRUCTIONS:

-NOTE-

PART I of this Alert Service Bulletin can be accomplished with the blade installed on the helicopter by the pilot or a licensed mechanic.

PART I. Before the first flight of every day.

1. Use detergent (C-318) and thoroughly clean the area to be checked on both sides of the blade. Refer to figure 1.
2. Check both sides of the blade at the area indicated on figure 1 as follows:
 - a. Visually inspect the doubler for edge void on both sides of the blade.
 - b. If void or de-bonding is found, remove the blade from service immediately.
3. If no void or de-bonding is found, the blade is serviceable continue Part I until Part II is completed.
4. Make log book entries to show that the PART I of this Alert Service Bulletin has been accomplished.

Part II Within the next 100 flight hours of operation, but no later than January 31, 2005, remove affected blades from service.

1. Remove and replace affected tail rotor blade. (Refer to the applicable 206L-MM)
2. Make log book entries to show that the PART II of this Alert Service Bulletin has been accomplished.

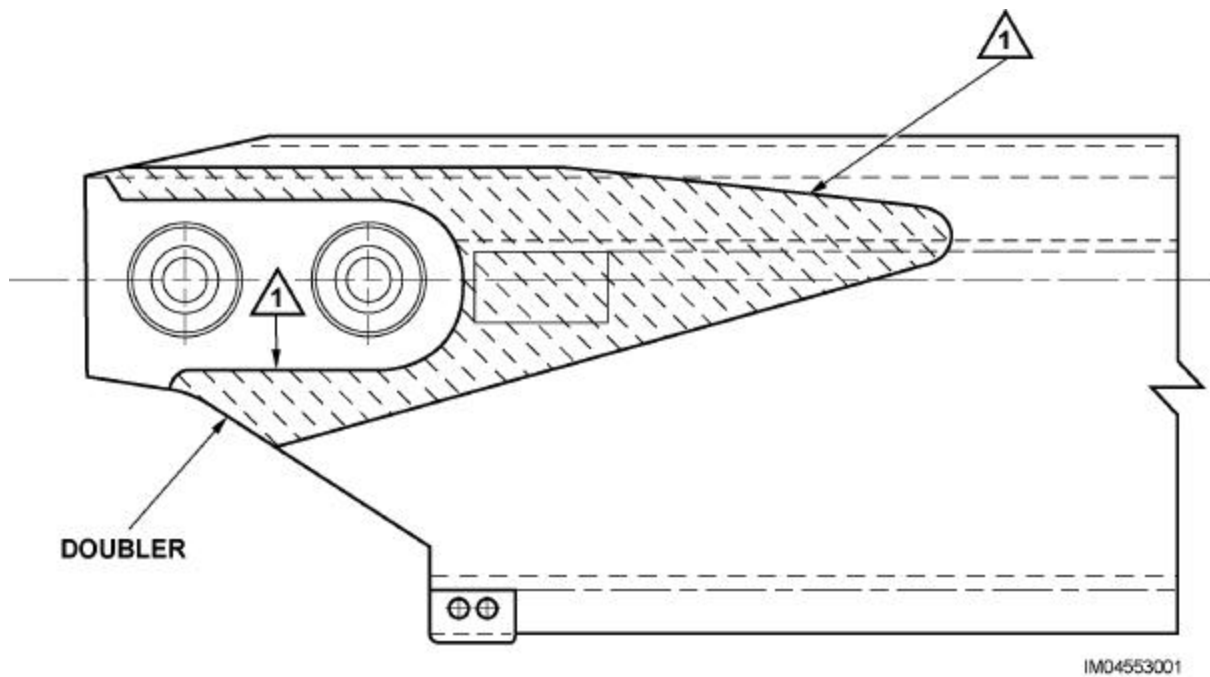

NOTE

 Inspect the doubler for edge void or evidence of de-bonding on both sides of the blade.

Figure 1. Inspect the doubler for edge void on both sides of the blade