

**ALERT SERVICE BULLETIN**



**NO.** 212-01-112

**DATE** 01-19-01

**PAGE** 1 of 5

<b>DATE</b>
<b>REV</b>

**MODEL AFFECTED:** 212

**SUBJECT:** MAGNETIC BRAKE P/N 204-001-376-003, ONE TIME INSPECTION OF.

**HELICOPTERS AFFECTED:** All Model 212 helicopter and all delivered spare Magnetic Brakes P/N 204-001-376-003.

[Model 212 helicopters serial numbers 35105 and subsequent will have the intent of this bulletin accomplished prior to delivery.]

[Model 212 helicopter equipped with IFR Kit P/N 212-706-106 do not require the accomplishment of this bulletin]

**COMPLIANCE:** Within the next 300 hours of operation after receipt of bulletin but no later than August 1, 2001.

**DESCRIPTION:**

Bell Helicopter has recently received a report that magnetic brake P/N 204-001-376-003 adjustable stop screws P/N MS51959-3 had backed out which limited the travel of the arm assembly. Investigation revealed the stop screws had been installed without the proper adhesive. These Magnetic Brakes were manufactured by Memcor Truohm, Inc. under their P/N MP498-3. Magnetic Brakes P/N 204-001-376-003 made by other manufacturers are not affected by this bulletin.

This Alert Service Bulletin (ASB) is issued to impose a one-time inspection to verify the installation of the adjustable stop screws of magnetic brake P/N 204-001-376-003.

**APPROVAL:**

The engineering design aspects of this bulletin are FAA/DER approved.

7851 55192 REV 1198

**MANPOWER:**

Approximately 3.0 man-hours are required to complete this bulletin. Man-hours are based on hands-on time, and may vary with personnel and facilities available.

**MATERIAL:**

**Required Material:**

None required.

**Consumable Material:**

The following material is required to accomplish this bulletin, but may not require ordering, depending on the operator's consumable material stock levels. This material may be obtained through your Bell Helicopter Textron Supply Center.

<u>Part Number</u>	<u>Nomenclature</u>	<u>Quantity</u>	<u>Reference</u>
MILS22473 GR AA 50cc	Adhesive/Sealant	A/R	C-320
F900, Yellow	Torque Seal (Inspection Ink)	A/R	N/A

**SPECIAL TOOLS:**

None required.

**WEIGHT AND BALANCE:**

Not affected.

**ELECTRICAL LOAD DATA:**

Not affected.

**REFERENCES:**

BHT-212-IPB Illustrated Parts List, Chapter 67  
BHT-212-MM Maintenance Manual, Chapter 67  
BHT-ALL-SPM Standard Practice Manual

**PUBLICATIONS AFFECTED:**

None affected.

**ACCOMPLISHMENT INSTRUCTIONS:**

1. Magnetic Brake P/N 204-001-376-003 may be installed on aircraft or may be held as a spare part. If a spare magnetic brake is manufactured by Memcor Truohm under P/N MP498-3, comply with steps 6 through 12 and then return magnetic brake to spare stock. If magnetic brake is installed on aircraft, proceed to step 2.
2. Disconnect battery.
3. Gain access to the to the cyclic and anti- torque flight control system magnetic brake (4, figure 1).
4. Using a mirror and a flashlight, inspect each Magnetic Brake installed to determine if it is manufactured by Memcor Truohm, Inc. by identifying the P/N MP498-3. If the Magnetic Brake is P/N MP498-3, continue with step five (5) of this Alert Service Bulletin. If the Magnetic Brake is not manufactured by Memcor Truohm, Inc. proceed to step 14 of this Alert Service Bulletin.
5. Remove cyclic fore & aft and lateral magnetic brakes from aircraft.

**-NOTE-**

Anti-torque magnetic brake does not have to be removed from aircraft to perform the following check.

6. Using a suitable torque wrench and screw driver bit apply 10 inch/lbs(1.12 Nm) force to screw(s) (1 figure 1) in a counterclockwise direction. If screw(s) (1) do not move, proceed to step 12. If any movement is found on screw(s) (1) proceed to the following steps.

**-NOTE-**

If the inspection reveals that screw(s) (1) has disengaged, inspect arm assembly (4) for mechanical damage created by screw (1). If mechanical damage is found, the depth shall not exceed 0.030 inch (0.762 mm). Acceptable damage may be smoothed and treated in accordance with the Standard Practice Manual Chapter 3 for Chemical Film. If damage is greater than 0.030 inch (0.762 mm) contact Product Support Engineering.

7. Remove screw(s) (1) and stop limit(s) (2) from magnetic brake (4).
8. Clean residue adhesive from magnetic brake (4) screw holes and screw(s) (1) with compressed air.
9. Apply adhesive (C-320) to screw (s) (1) threads and install in magnetic brake (4) hand tight.
10. Adjust the stop limit(s) (3) to achieve the arm assembly shaft travel as per dimensions in BHT-212-MM Maintenance Manual, Chapter 67.
11. Once shaft travel is obtained, torque screws (1) 5 to 10 in-lbs (0.56 to 1.12 Nm).
12. Apply torque seal inspection ink to screws (1) and to stop limits (2).
13. Re-install cyclic fore & aft and lateral magnetic brakes into aircraft.
14. Re-install cyclic and anti-torque magnetic brake access panels.
15. Connect battery.
16. Make an entry in the helicopter historical records indicating compliance with this Alert Service Bulletin.

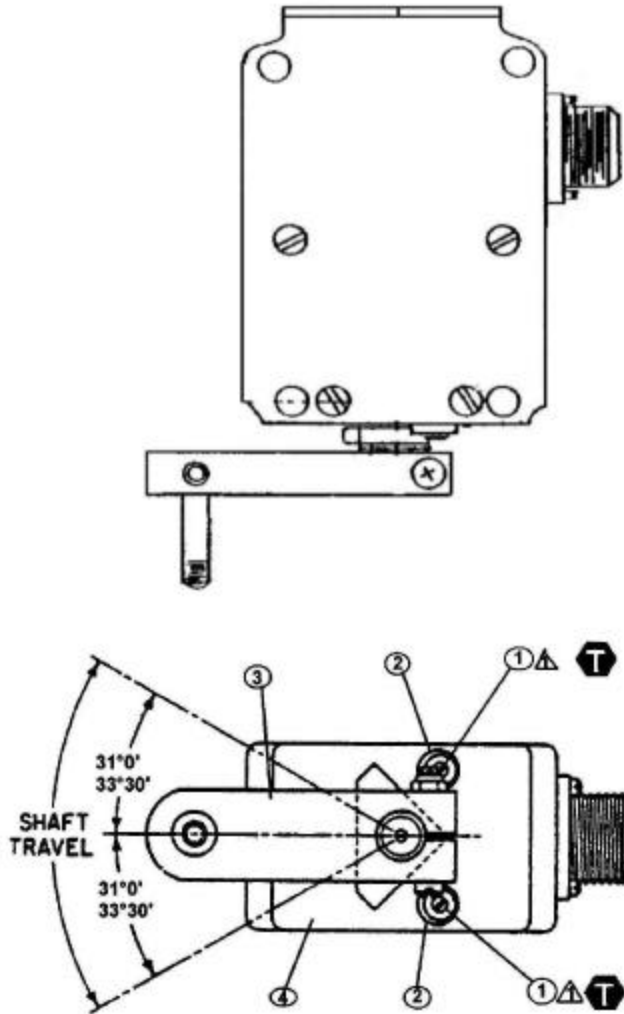



**MAGNETIC BRAKE ASSEMBLY P/N 204-001-376-003**

**LEGEND**

- 1. Screw MS51959-3
- 2. Stop Limit
- 3. Arm Assembly
- 4. Brake Assembly

**NOTE**

-  Bond screw with adhesive C-320
-  5 to 10 IN-LBS  
(0.56 TO 1.12 Nm)

**FIGURE 1**