

ALERT SERVICE BULLETIN

Bell Helicopter **TEXTRON**

A Subsidiary of Textron Inc.

NO. 212-02-118

DATE Nov. 22, 2002

PAGE 1 of 6

DATE

REV

MODEL AFFECTED: 212

SUBJECT: TAIL ROTOR BLADE ASSEMBLIES P/N
212-010-750-113/-115 INSPECTION AND
REWORK OF.

HELICOPTERS AFFECTED: All Model 212 helicopters with Tail Rotor Blade Assemblies 212-010-750-113 / -115 with Serial Number A or AFS-12400 THROUGH A or AFS-12711.

The following Tail Rotor Blade Assemblies will have the intent of this bulletin accomplished prior to delivery:

AFS-12577	A-12428	A-12431
A-12436	A-12473	A-12516
A-12535	A-12563	A-12567
A-12608	A-12611	A-12619
A-12621	A-12634	A-12642
A-12660	A-12667	A-12668
A-12669	A-12670	A-12671
A-12694	A-12700	A-12701
A-12703	A-12712 and subsequent.	

COMPLIANCE: Within the next 300 hours of flight time following receipt of this bulletin.

DESCRIPTION:

Bell Helicopter has discovered that certain serial number tail rotor blades may have been manufactured with mechanical damage located on the inside of the root cuff. The mechanical damage may be identified on the inside of the upper and lower grip plates. The exact location varies, but generally located outboard of the outboard blade bolt attachment hole. See figure 1 and 2.

7851 55192 REV 1198

This bulletin provides instructions to inspect and if necessary, repair any damage noted in the subject area.

APPROVAL:

The engineering design aspects of this bulletin are FAA/DER approved.

MANPOWER:

Approximately 4.0 man-hours are required to complete this bulletin. Man-hours are based on hands-on time, and may vary with personnel and facilities available.

MATERIAL:

Required Material:

The following material is required for the accomplishment of this bulletin and may be obtained through your Bell Helicopter Textron Supply Center.

<u>Part Number</u>	<u>Nomenclature</u>	<u>Quantity</u>	<u>Reference</u>
MIL-C-81706 1 QT	Chemical Film Material	A/R	C-100
180 GRIT CLOTH	Abrasive Cloth	A/R	C-423
SCOTCHBRIDE TY-A	Abrasive Pad	A/R	C-407
METHYL ETHYL KETONE	Methyl-Ethyl-Ketone	A/R	C-309
TT-I735 ISOPROPYL	Alcohol	A/R	C-339

SPECIAL TOOLS:

None required

WEIGHT AND BALANCE:

Not affected

ELECTRICAL LOAD DATA:

Not affected

REFERENCES:

BHT-212-MM Maintenance Manual
BHT-212-CR&O Component Repair and Overhaul Manual

PUBLICATIONS AFFECTED:

None affected

ACCOMPLISHMENT INSTRUCTIONS:

1. Ensure that the location of each tail rotor blade is identified in relation to the hub assembly. Ensure that all hardware and balance weights are identified so they can be reinstall at the same location.
2. Remove tail rotor blades from helicopter. Refer to Bell-212-MM for instruction.
3. Remove pitch horn from blade. Refer to Bell-212-CR&O manual for instruction.
4. Clean off all paint inside blade cuff areas per figure 1 and 2.
 - a. Remove paint by sanding with 120 grit abrasive cloth or paper (C-423)
 - b. Clean residual paint with an abrasive pad (C-407) and Methyl-Ethyl-Ketone (C-309) or alternate.
 - c. Wipe area with a clean cloth dampened with alcohol (C-339)
5. Inspect area for mechanical damage.
6. If a defect is found, perform a penetrant inspection of the grip plates to ensure that no cracks are present.

CAUTION

If cracks are detected, remove blade from service and notify Product Support Engineering for further instruction.

-NOTE-

If the depth of the damage exceed 0.030 inch (0.762 mm) or the damage is located in the non-reparable area per figure 2, notify Product Support Engineering for further instruction.

7. Blend any damage found to a maximum depth of 0.030 inch (0.762 mm). Blend over a length of at least 10 times the depth on all edges of the damage.
8. Surface finish of repair shall be similar to surrounding area.
9. Apply chemical film (C-100) to reworked area.
10. Refinish tail rotor blade assembly per Bell-212-CR&O.
11. Install pitch horn
12. Install tail rotor blade assemblies on aircraft.
13. Annotate records to indicate compliance with this bulletin.

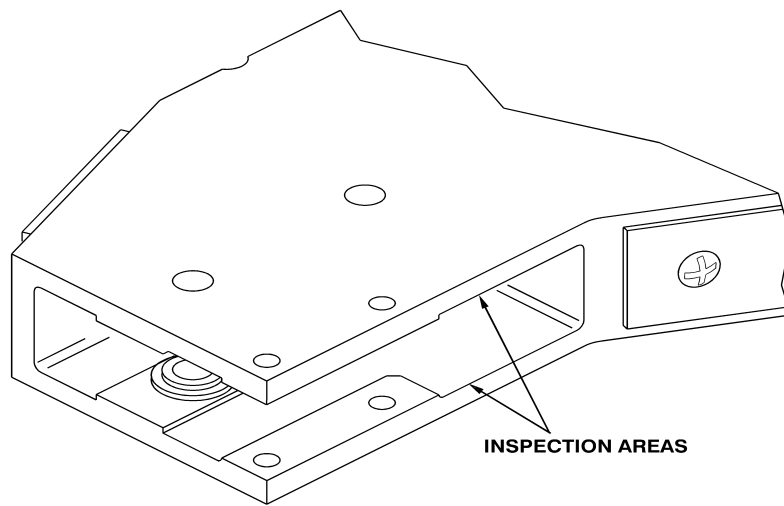

02576001

Inspections Areas

FIGURE 1

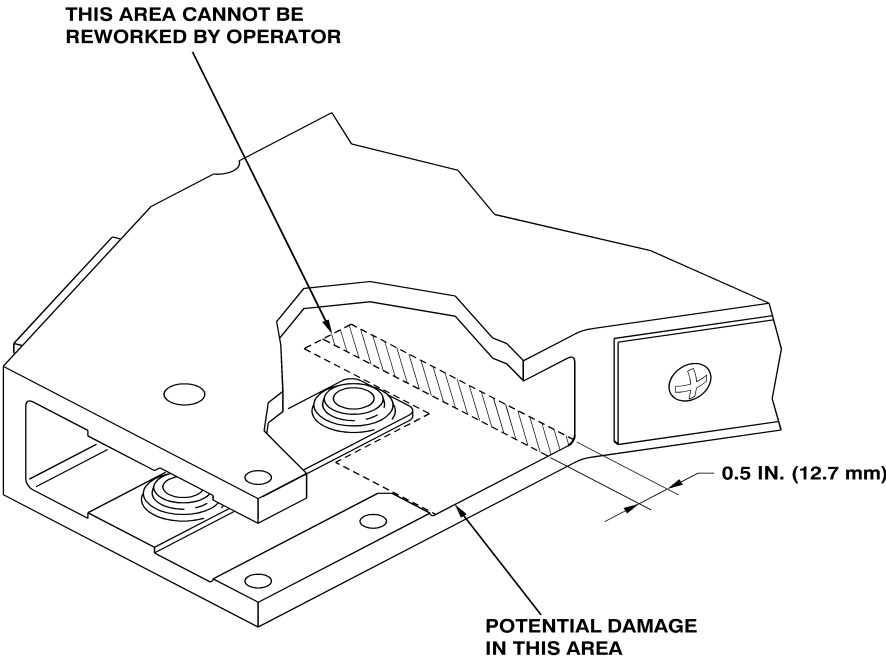

02576002

Detailed Inspection

FIGURE 2