

ALERT SERVICE BULLETIN
Bell Helicopter **TEXTRON**
A Subsidiary of Textron Inc.

NO. 214-06-68
DATE Aug 11, 2006
PAGE Page 1 of 7

DATE
REV

MODEL AFFECTED: 214B/214B-1

SUBJECT: **TAIL ROTOR DRIVESHAFT HANGER ASSEMBLY BEARING, P/N 214-040-606-101, ONE TIME INSPECTION.**

HELICOPTERS AFFECTED: All 214B/B-1 helicopters with P/N 214-040-606-101 bearings installed and all spare P/N 214-040-606-101 bearings.

- NOTE -

214B/B-1 helicopters with P/N 214-040-600-113 and/or -117 Tail Rotor Driveshaft Hanger Assemblies will have the P/N 214-040-606-101 bearings installed. 214B/B-1 helicopters with P/N 214-040-600-001, -005, -101, -103, -107, and/or -109 Tail Rotor Driveshaft Hanger Assemblies may have P/N 214-040-606-101 bearings installed as a result of spare parts replacement.

COMPLIANCE: **PART 1:** At the next scheduled inspection or overhaul, which ever occurs first, of the tail rotor driveshaft hanger bearing assemblies but not later than 45 days from the date of this Alert Service Bulletin.

PART 2: Immediately upon receipt of this Alert Service Bulletin.

DESCRIPTION:

During a routine overhaul, an operator found P/N 214-040-606-101 bearings with unusual dents, or dimples, along the outer diameter of the bearing seal faces. Investigation by Bell Helicopter has determined these are the result of a defective bearing manufacturing process. In service, dented or dimpled seals could contact the bearing cage and eventually result in bearing failure.

This Alert Service Bulletin requires a one time inspection of installed and spare P/N 214-040-606-101 tail rotor drive shaft hanger bearings for evidence of dents, or dimples, in the seal face. Discrepant bearings must be removed from service.

APPROVAL:

Not required.

MANPOWER:

Approximately 0.5 man-hours per bearing will be required to accomplish the inspection portion of this bulletin (does not include time required to gain access for inspection).

WARRANTY:

Owner/Operators of the affected helicopters that have performed the required inspection as outlined in the bulletin and find a defective seal in the bearing are eligible to receive a special warranty credit for replacement part contained in the "Required Materials" section of this bulletin.

-NOTE-

Owner Operators that have new unused 214-060-606-101 in their stock; DO NOT open the sealed package to check for seal anomalies. Opening the package may cause premature oxidation to the bearing surfaces. Simply order a new bearing and file a warranty claim for credit. An RMA will be created for you to return the bearing.

To Receive Warranty Credit:

For new (unused) bearings or defective bearings. Purchase the required parts from an Approved BHTI supply source. Submit a completed MMIR to the Bell Warranty Dept. no later than 30 days after the completion of this bulletin but no later than 31 December, 2006. Warranty claims submitted after 31 December ,2006 will not be considered for the special warranty.

Warranty for labor is not a subject of this ASB.

MATERIAL:

Required Material:

The following material may be required for the accomplishment of this bulletin and may be obtained through your Bell Helicopter Textron Supply Center.

PART II

<u>Part Number</u>	<u>Nomenclature</u>	<u>Quantity</u>
214-040-606-101	Bearing	As Required

Consumable Material:

The following material may be required to accomplish this bulletin, however this material is considered consumable (bench stock) material and may not require ordering depending on the operator's consumable material stock levels. This material may be obtained through your Bell Helicopter Textron Supply Center.

<u>Part Number</u>	<u>Nomenclature</u>	<u>Quantity</u>	<u>Reference</u>
204-040-755-005	Lubricant (Tube Pack)	AR	C-015
M83248/1-235	Packing	AR	----
M83248/1-237	Packing	AR	----
MS24665-153	Cotter Pin	AR	----

SPECIAL TOOLS:

None required for inspection. Refer to applicable maintenance publications for tools required to disassemble and reassemble the tail rotor drive shaft hanger bearing assemblies.

WEIGHT AND BALANCE:

Not required

ELECTRICAL LOAD DATA:

Not affected

REFERENCES:

BHT-214ST-MM, Chapters 12 and 65
 BHT-214ST-CR&O, Chapter 65
 BHT-214ST-IPB, Chapter 65

PUBLICATIONS AFFECTED:

None affected

ACCOMPLISHMENT INSTRUCTIONS:

PART 1 – INSTALLED BEARINGS

- NOTE –

214B/B-1 helicopters with P/N 214-040-600-113 and/or –117 Tail Rotor Driveshaft Hanger Assemblies will have the P/N 214-040-606-101 bearings installed. 214B/B-1 helicopters with P/N 214-040-600-001, -005, -101, -103, -107, and/or –109 Tail Rotor Driveshaft Hanger Assemblies may have P/N 214-040-606-101 bearings installed as a result of spare parts replacement.

1. Review helicopter records and/or other relevant historical records to determine if P/N 214-040-606-101 Bearings are installed in any P/N 214-040-600-001, -005, -101, -103, -107, and/or –109 tail rotor driveshaft hanger assemblies or if any P/N 214-040-600-113 or -117 tail rotor driveshaft hanger assemblies are installed. If the part number of the installed bearing can not be accurately determined from the records, then all hanger assemblies must be inspected.

NOTE

This inspection may be accomplished with the tail rotor hanger assemblies installed on the helicopter. Remove cowling as necessary to obtain clear access to both the forward and aft sides of the hanger assemblies to be inspected.

2. With a clean cloth, gently remove accumulated grease and dirt from the bearing seal faces and, using a mirror and a strong light, inspect all affected P/N 214-040-600-001, -005, -101, -103, -107, and/or –109 tail rotor driveshaft hanger assembly bearings for damaged seals as shown in Figures 1 and 2.
 - a. Tail rotor driveshaft hanger assemblies with damaged bearings installed may not be continued in service until serviceable bearings have been installed.
 - b. Remove affected assemblies and forward to an overhaul facility for bearing replacement.

- c. All bearings with damaged seals which have been removed from hanger assemblies are not airworthy and are not repairable.
3. Inspect all installed P/N 214-040-600-113 and/or –117 tail rotor driveshaft hanger bearing assemblies for damaged P/N 214-040-606-101 bearing seals in accordance with paragraph 2 above.

PART 2 – SPARE (UNINSTALLED) BEARINGS AND HANGER BEARING ASSEMBLIES

1. Inspection of spare, individually packaged, bearings will be performed by the bearing manufacturer.
 - a. All spare P/N 214-040-606-101 bearings provided by Bell Helicopter are shipped in vacuum sealed packaging.
 - b. Do not remove the bearings from the sealed packaging and do not attempt to inspect seals through the packaging.**
 - c. Return all spare P/N 214-040-606-101 bearings in their original sealed packaging to Bell Helicopter in accordance with the WARRANTY SECTION of this Alert Service Bulletin.
2. Inspect spare P/N 214-040-600 tail rotor driveshaft hanger assemblies in accordance with Part 1 of this Alert service Bulletin.

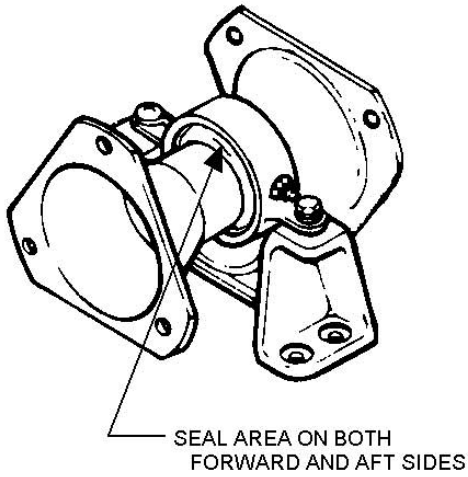

**214-040-600
TYPICAL HANGER BEARING ASSEMBLY**

NOTE: -001, -101, -107, AND -113 HAVE A FLEX COUPLING INSTALLED ON THE FORWARD END.

1. Inspect both seals of each bearing in each affected hanger assembly.

2. Photos show uninstalled bearings and are for reference only.

3. Do not remove bearings from hanger assembly for inspection. Remove installed bearings only if damaged seals are found.

4. Do not mistake scribed index line for damage. There will be one index line per seal. Index line on the bearing outer race will not be visible with bearing installed in the hanger.

5. Dents, or dimples, can be very pronounced or subtle. See Figure 2 for examples of each.



Dent/Dimple

Dent/Dimple

Scribed Index Line Typical



FIGURE 1

EXAMPLES OF TYPICAL
214-040-606-101 BEARING SEAL
DENTS/DIMPLES

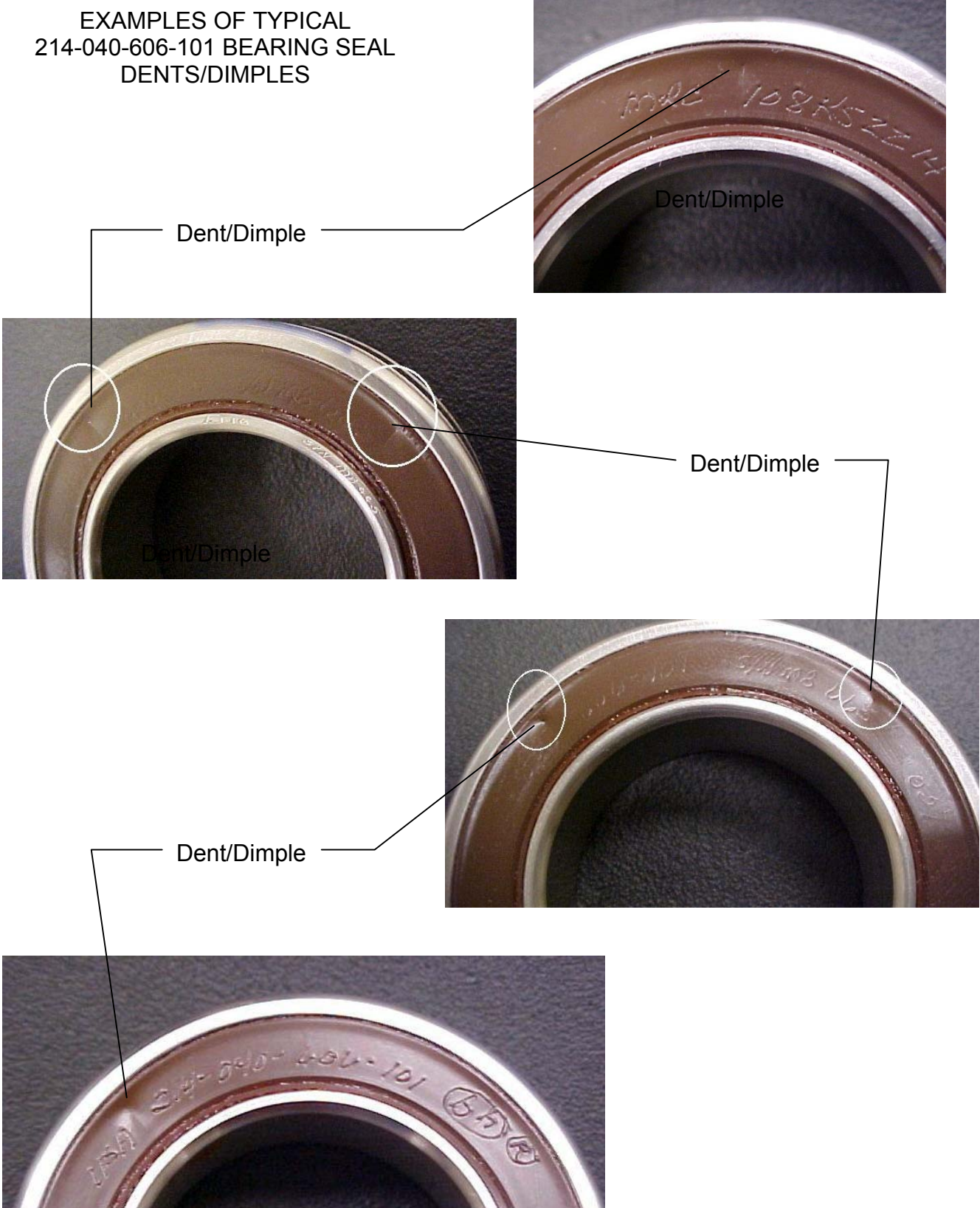

FIGURE 2