

ALERT SERVICE BULLETIN

Bell Helicopter **TEXTRON**

A Subsidiary of Textron Inc.

NO. 222-00-86

DATE 05-19-00

PAGE 1 of 6

DATE

REV

MODEL AFFECTED:

Model 222 and 222B

SUBJECT:

HYDRAULIC ACTUATOR SUPPORT P/N 222-040-125-001, INSPECTION OF

HELICOPTERS AFFECTED:

**Model 222 serial number 47006 through 47089.
Model 222B serial number 47131 through 47156.**

COMPLIANCE:

Within 25 hours following receipt of this bulletin.

DESCRIPTION:

A Model 222U helicopter was in flight when it experienced a control loss. The cause of control loss was attributed to the main rotor hydraulic actuator support separating from the transmission. All retaining studs were found sheared or pulled out at the junction of the support with the transmission upper and lower cases.

The purpose of this bulletin is to require a one-time inspection of the hydraulic actuators support installation by accomplishing a torque check of the support attaching nuts. In addition, a Revision to the maintenance manual will introduce a recurring torque check of the support attaching nuts.

APPROVAL:

Not required

MANPOWER:

Approximately .5 man-hour is required to complete this bulletin if the support is not removed from the transmission. An additional 6 man-hours will be required to remove, inspect and reinstall the support. Man-hours are based on hands-on time, and may vary with personnel and facilities available.

MATERIAL:

Required Material:

The following material is required for the accomplishment of this bulletin and may be obtained through your Bell Helicopter Textron Supply Center.

<u>Part Number</u>	<u>Nomenclature</u>	<u>Quantity</u>
* MS21042L4	Nut	4
* MS21042L5	Nut	4
* 222-040-268-001	Washer	4
* 222-040-268-003	Washer	4

* Nuts and washers are required only if actuator support is removed for inspection.

Consumable Material:

The following material is required to accomplish this bulletin, but may not require ordering, depending on the operator's consumable material stock levels. This material may be obtained through your Bell Helicopter Textron Supply Center.

<u>Part Number</u>	<u>Nomenclature</u>	<u>Quantity</u>	<u>Reference</u>
* MILS8784CLB2	Sealant	3.5OZ	C-328

* Sealant is required only if actuator support is removed for inspection.

SPECIAL TOOLS:

None required

WEIGHT AND BALANCE:

Not affected

ELECTRICAL LOAD DATA:

Not affected

REFERENCES:

BHT-222/222B-MM-1, Chapter 66 and 71
BHT-222-CR&O-2, Chapter 63
BHT-ALL SPM

PUBLICATIONS AFFECTED:

BHT-222/222B-MM-1, Chapter 5
BHT-222-CR&O-2, Chapter 63

ACCOMPLISHMENT INSTRUCTIONS:

1. Remove fairings and cowlings as required to gain access to the hydraulic actuators support. Refer to BHT-222/222B-MM-1, Chapter 71.
2. Verify that the dowel pins installed in the transmission upper case are not missing and that evidence of sealant is present at the joint between the actuator support and the transmission. Refer to figure 2. If any of the pins are missing and/or if no sealant is visible, remove the actuator support and proceed to step 5.
3. Verify torque of actuators support P/N 222-040-125-001 attaching nuts. Apply the torque in the tightening direction. For the upper row of nuts, if 40 in. lb. is reached without nut movement, increase the torque to 50-70 in.lb plus tare. For the lower row of nuts, if 90 in. lb. is reached without nut movement, increase the torque to 100-140 in.lb plus tare.

-NOTE-

Anti fretting washers installed between the actuator support and the transmission lower case may be reinstalled provided the coating is not worn through or damaged

4. If two or more of the nuts within the upper row of the support attaching nuts move below 40 in.lb torque or two or more of the nuts within the lower row of the support attaching nuts move below 90 in.lb torque, remove the hydraulic actuators support from the transmission for further inspection and repair. Refer to BHT-222/222B-MM-1, Chapter 65 and BHT-222-CR&O-2, Chapter 63 for removal instructions. Discard nuts and washers.
5. If required, inspect the support P/N 222-040-125-001 in accordance with instructions in BHT-222-CR&O-2, Chapter 63. The holes at the lower and upper end of the support were manufactured to the dimensions shown in figure 1.
6. If required, inspect the transmission lower case assembly as follows:
 - a) Inspect surface of transmission case in contact with the actuator support for damage, fretting and corrosion. Refer to BHT-222-CR&O-2, Chapter 63 for damage/wear limits.

- b) Inspect the studs, retaining the actuators support, for condition of threads and for looseness. Replace damaged studs in accordance with BHT-222-CR&O-2, Chapter 63 and BHT-ALL-SPM.
7. If required, inspect the transmission upper case assembly as follows:
- a) Inspect surface of transmission case in contact with the actuator support for damage, fretting and corrosion. Maximum depth and/or size of corrosion, wear, scratches, nicks and marks shall not exceed 0.005 inch depth, 40% of any one square inch or more than 20% of the total surface. Pitting/corrosion around studs and dowel pins shall not exceed 0.005 depth or 50% of the circumference of the stud/dowel pin.
 - b) Inspect the studs, retaining the actuators support, for condition of threads and for looseness. Replace damaged studs in accordance with BHT-222-CR&O-2, Chapter 63 and BHT-ALL-SPM.
 - c) Inspect the dowel pins in transmission case for damage, fretting, corrosion and looseness. The large outboard pins should measure 0.500 inch minimum and protrude 0.55 inch from the surface of the case. The small inboard pins should measure 0.375 inch minimum and protrude 0.45 inch from the surface of the case. Refer to Figure 2
8. If removed for inspection, reinstall actuators support on the transmission with new nuts and washers in accordance with instructions in BHT-222-CR&O-2, Chapter 63. Reinstall all parts previously removed in accordance with BHT-222/222B-MM-1, Chapter 66.
9. Reinstall fairings and cowlings previously removed. Refer to BHT-222/222B-MM-1, Chapter 71.
10. Annotate helicopter records to reflect compliance with this bulletin.

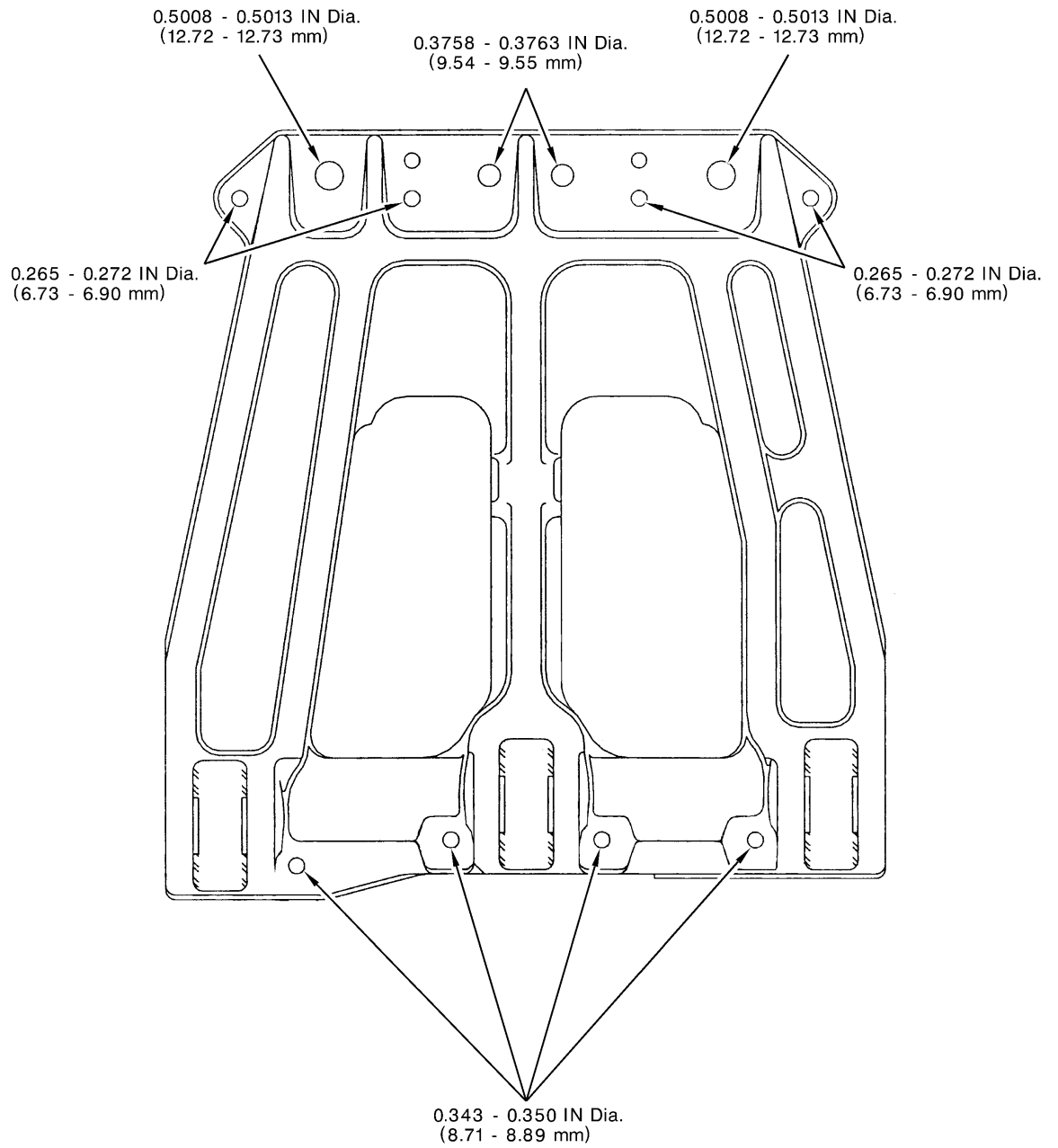

**Hydraulic Actuator Support
Assembly P/N 222-040-125-001
Figure 1**

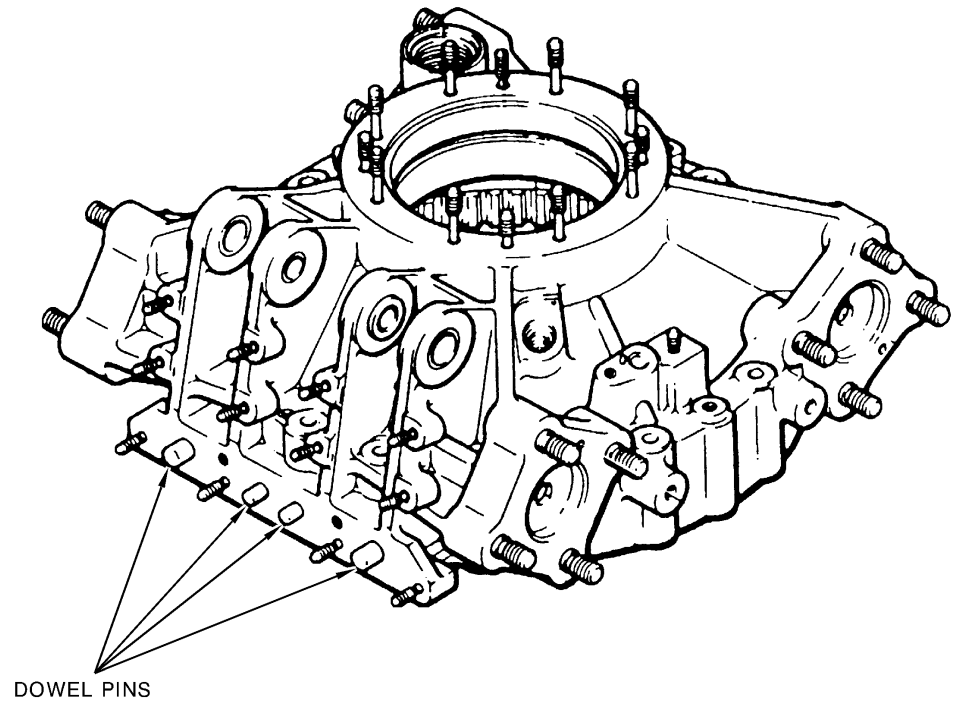

**Transmission Top Case
Assembly P/N 222-040-061-101
through 105
Figure 2**