

ALERT SERVICE BULLETIN

Bell Helicopter **TEXTRON**
A Subsidiary of Textron Inc.

NO. 222-01-89

DATE 02-07-01

PAGE 1 of 5

DATE
REV

MODEL AFFECTED: Model 222 and 222B

SUBJECT: UPPER FUEL ENCLOSURE, RIGHT SIDE
ADDITION OF DRAIN PROVISION

HELICOPTERS AFFECTED: Model 222 S/N 47006 through 47089
Model 222B S/N 47131 through 47156

COMPLIANCE: At the next annual inspection, but no later than
December 31, 2001.

DESCRIPTION:

Bell Helicopter Textron has determined that a condition exists that could result in an accumulation of fuel or water in the right hand upper fuel enclosure area located at approximate STA 268.03 to STA 281.87 and W.L. 53.50.

This bulletin provides the procedures to remove the sealant from the existing forward tooling hole located in panel assembly P/N 222-031-470-103 to provide enclosure drainage provision.

APPROVAL:

The engineering design aspects of this bulletin are Transport Canada approved.

MANPOWER:

Approximately 5 man-hours are required to complete this bulletin. Man-hours are based on hands-on time, and may vary with personnel and facilities available.

7851 55102 REV 1198

MATERIAL:

Consumable Material:

The following material is required to accomplish this bulletin, but may not require ordering, depending on the operator's consumable material stock levels. This material may be obtained through your Bell Helicopter Textron Supply Center.

<u>Part Number</u>	<u>Nomenclature</u>	<u>Quantity</u>	<u>Reference</u>
MILS8784CLB2,3.5OZ	Sealant	1	C-328

SPECIAL TOOLS:

None required.

WEIGHT AND BALANCE:

Not affected.

ELECTRICAL LOAD DATA:

Not affected.

REFERENCES:

BHT-222/222B-MM-1

BHT-222-IPB chapter 28

BHT-222-IPB chapter 53

BHT-222B-IPB chapter 28

BHT-222B-IPB chapter 53

PUBLICATIONS AFFECTED:

None affected.

ACCOMPLISHMENT INSTRUCTIONS:

-NOTE-

Adequate drainage provision already exists in the upper fuel enclosure located on the left side of the aircraft

1. Gain access to work area following instructions in the appropriate maintenance manual. Remove the seat cushions and seat backs from the rear passenger seats. Refer to BHT-222/222B-MM-1, chapter 25.

-NOTE-

Panel assembly P/N 222-031-426-104 is installed with sealant per MIL -S-8784CLB2

2. Remove fuel cell access panel P/N 222-031-426-104 located on the lower R/H side of STA 270 bulkhead. Refer to Figure 1 and refer to BHT-222/222B-MM-1, chapter 53.

-NOTE-

Ensure fuel level is close to under seat and upper fuel cell junction before proceeding with bulletin to permit upper right hand side of fuel cell to be pushed back in airframe cavity.

CAUTION

Do not fold a cold fuel cell. Damage or cracks can occur to fuel cell. Make sure the fuel cell is warm enough to be flexible. Do not exceed 125 °F (52 °C) when you apply heat to the fuel cell

3. If necessary, apply heat to the fuel cell with heat lamps for approximately 2 hours.
4. Carefully push upper right hand side of fuel cell back into airframe cavity only sufficiently to permit access to working area.

CAUTION

If fuel is observed coming from tooling hole when it is unplugged, troubleshooting will be required to determine fuel source

- NOTE -

If for any reason tooling hole cannot be unplugged by working from the bottom of panel P/N 222-031-470-103 it will then be necessary to access the top side of panel P/N 222-031-470-103. This would require removing access panel P/N 222-031-408-148 (and auxiliary fuel tank if installed) located on the R/H side of the hat box area

Tooling hole is located at approximate STA 271.00, B.L. 22.25, W.L. 54.00 in panel assembly P/N 222-031-470-103

5. Locate forward tooling hole in panel assembly P/N 222-031-470-103 and unplug hole using a plastic scrapper and a pin punch or a similar object. Refer to Figure 1.
6. Reposition fuel cell upper right hand side into airframe cavity.
7. Install access panel P/N 222-031-426-104 with sealant MIL-S-8784CLB2. Refer to BHT-222/222B-MM-1, chapter 53.
8. Install the seat cushions and seat backs on the rear passenger seats. Refer to BHT-222/222B-MM-1, chapter 25.
9. Annotate helicopter records to reflect compliance with this bulletin.

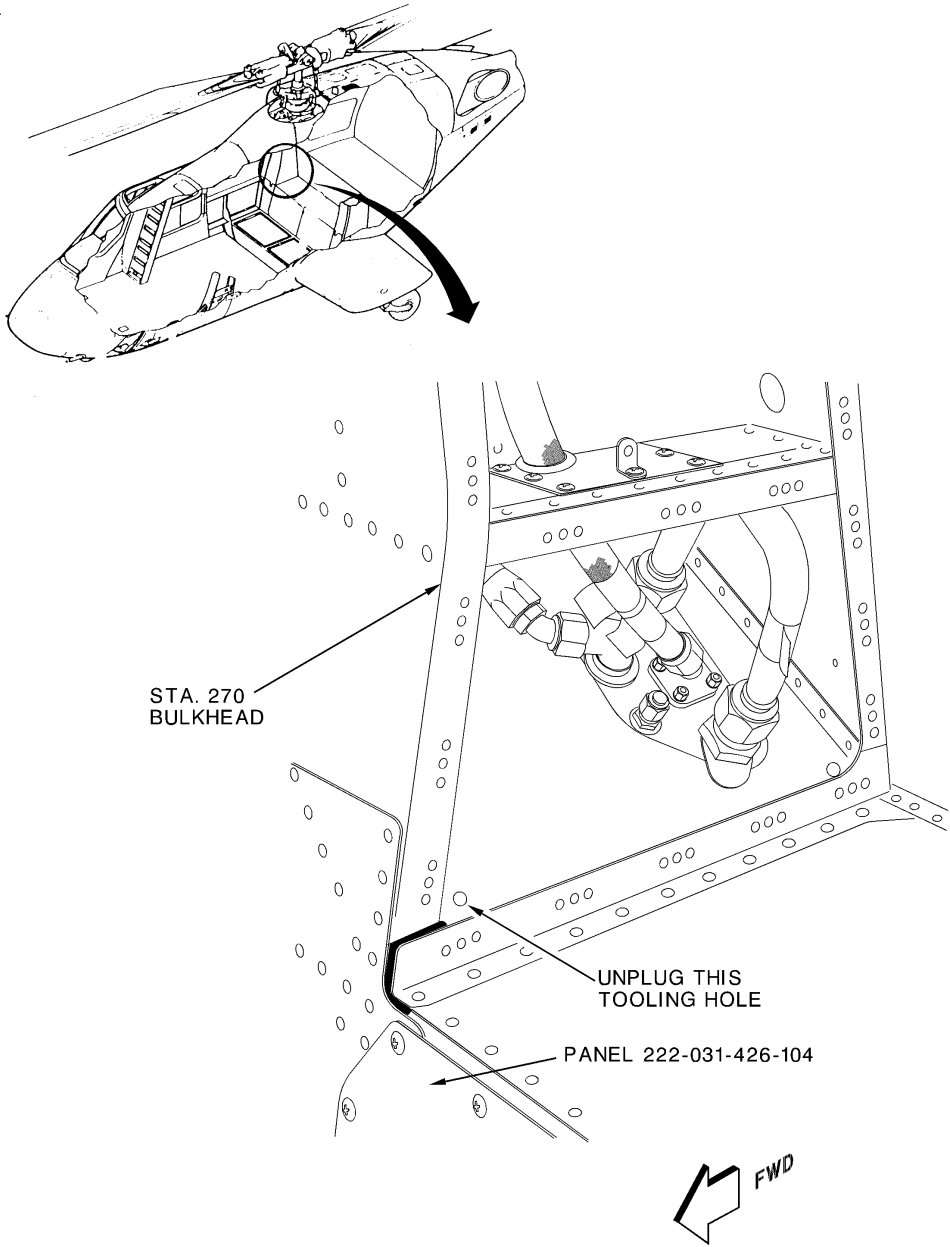

NOTES

Illustration shown with hat-box R/H access panel 222-031-408-148 removed for clarity.

FIGURE 1