

ALERT SERVICE BULLETIN
Bell Helicopter **TEXTRON**

A Subsidiary of Textron Inc.

NO. 412-05-115

DATE Jan 17, 2005

PAGE 1

DATE
REV

MODEL AFFECTED: All model 412, 412EP

SUBJECT: AERONAUTICAL ACCESSORIES, INC. ASB No. AA-03017 FOR EXTERNAL HOIST KITS P/N 412-130-XXX, 412-140-XXX OR 412-150-XXX.

HELICOPTERS AFFECTED: ALL Model 412 / 412EP helicopters with Aeronautical Accessories, Inc. External Hoist Kit P/N 412-130-XXX, 412-140-XXX or 412-150-XXX

COMPLIANCE: See Revision A of vendor bulletin, note that the only change in Revision A is that the compliance is now 50 flight hours upon receipt of this bulletin instead of immediately.

DESCRIPTION:

The purpose of this bulletin is to achieve complete distribution of the attached vendor bulletin to the current affected model distribution list on record by Bell Helicopter.

APPROVAL:

See vendor bulletin approval.



AERONAUTICAL ACCESSORIES, INC.

P.O. BOX 3689

BRISTOL, TENNESSEE 37625-3689 U.S.A.

TELEPHONE: 423-538-5151

800-251-7094

TELEFAX: 423-538-8469 E-MAIL: sales@aero-access.com

ALERT SERVICE BULLETIN

ASB No. AA-03017

REVISION A

- SUBJECT:** External Hoist Kits
P/Ns 412-130-XXX, 412-140-XXX or 412-150-XXX
- MODELS AFFECTED:** Bell Helicopter Textron 412, 412EP, 412CF,
Agusta AB412, AB412EP with the subject External
Hoist Kit installed.
- COMPLIANCE:** This bulletin shall be complied within 50 flight
hours of receipt.
- DESCRIPTION:** This Alert Service Bulletin is being issued in
response to an incident of electrical interference
with basic aircraft equipment (i.e. AHRS Gyro,
Generator, instruments, etc). This bulletin
provides the procedures and identifies the
materials required to accomplish a modification to
improve electrical bonding to preclude electrical
interference. This document is FAA/DER
approved.
- MANPOWER:** Approximately 2.0 hours.

IF OWNERSHIP OF AIRCRAFT HAS CHANGED, PLEASE FORWARD THIS BULLETIN TO NEW OWNER

MATERIAL:

The following materials are required to comply with this bulletin:
(Parts marked with asterisk (*) are available from Aeronautical Accessories, Inc. at no cost as kit part number ASB-03017-001)

AN4-6A Bolt, Qty: 3*

AN4-7A Bolt, Qty: 1*

NAS1149D0416J Washer, Qty: 6*

MS21042L4 Nut, Qty: 3*

100 grit sandpaper

Chemical conversion coating (MIL-C-81706, Type III or equivalent)

REQUIRED TOOLS:

Socket-head Wrench

Torque Wrench

WEIGHT AND BALANCE:

Not affected

PUBLICATIONS AFFECTED:

None affected.

ACCOMPLISHMENT INSTRUCTIONS:

(Breeze-Eastern Hoist - P/N 412-150-XXX or TRW/Lucas Hoist 412-140-XXX)

1. Locate Bonding Bracket (412-153-720) as shown in Figure 1.
2. Remove any existing blankets or trim to gain access to the area. Retain for reinstallation.
3. Drill out the three rivets attaching the Bonding Bracket to the airframe (Ref. Figure 1).

CAUTION

Extreme care should be exercised when drilling into the transmission area.

4. Increase the diameter of the three remaining holes by using a 1/4" (.249-.255 dia.) drill bit.

CAUTION

Extreme care should be exercised during the following steps to prevent excessive metal removal or damage to the bare metal bond surface.

5. Using 100 grit sandpaper or dual action sanding, incrementally remove up to a maximum of .005 from the backside of the Bonding Bracket. Wipe the exposed surface with clean cheesecloth. The cheesecloth shall be either dry or wetted with isopropyl alcohol.

CAUTION

Chemical conversion coating is highly corrosive. Do not allow the coating or rinse water to run into cracks, crevices, seams or joints.

6. Apply a coating of chemical conversion coating (MIL-C-81706, Class 3 or equivalent) to the bond surface using a nonmetallic brush. Allow coating to remain on bond surface for 5 seconds maximum. This produces a light iridescent yellow finish on the bond surface.
7. Remove excess chemical conversion coating from the bond surface by blotting with a clean dry cheesecloth. Allow the bond surface to air-dry or gently wipe bond surface with cheesecloth.
8. Install Bolts, Washers and Nuts as shown in Figure 1.

NOTE

Removal of the access panel below the Bonding Bracket will be helpful to gain access to the inside of the transmission island.

9. Clean up area and reinstall any blankets or interior trim removed to gain access.

Any questions regarding this bulletin should be addressed to:

**AERONAUTICAL ACCESSORIES, INC.
PRODUCT SUPPORT
1-800-251-7094**

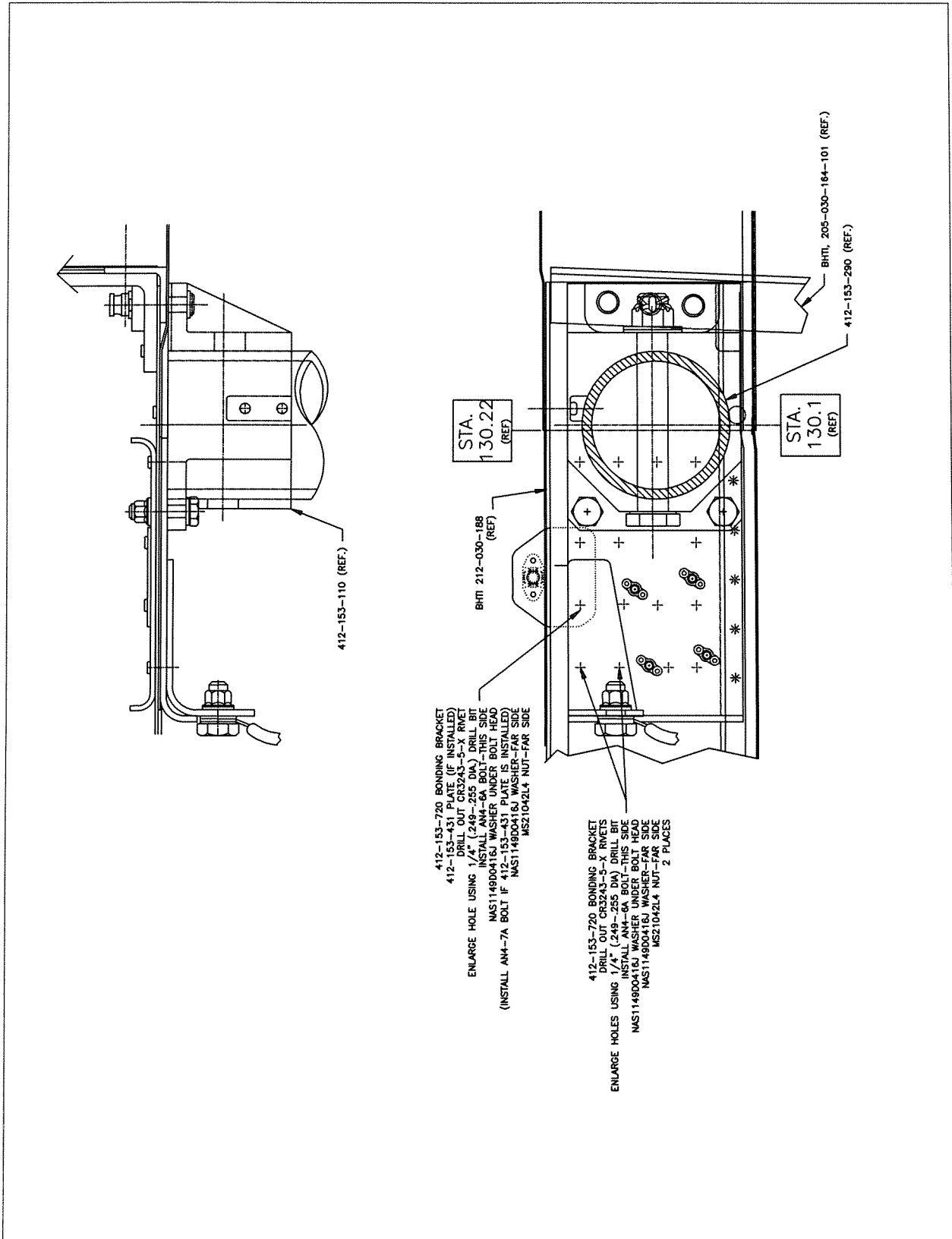

Figure 1