

ALERT SERVICE BULLETIN

REVISION NOTICE

Bell Helicopter **TEXTRON**

A Subsidiary of Textron Inc.

DATE 01-19-00

TO: **All Owners/Operators of Bell 412 Helicopters**

SUBJECT: **REVISION "A" TO ALERT SERVICE BULLETIN 412-99-97: (HIGH LANDING GEAR AFT CROSSTUBE ASSEMBLY P/N 412-050-011-ALL AND P/N 412-050-045-105-/107/107A, ASSIGNMENT OF A RETIREMENT LIFE)**

Revision "A" to this bulletin provides additional clarity by stating the specific high landing gear aft crosstube assembly affected by the assignment of the retirement life.

7851 60046 REV 1198

AN APPROPRIATE ENTRY SHOULD BE MADE IN THE AIRCRAFT LOG BOOK UPON ACCOMPLISHMENT
IF OWNERSHIP OF AIRCRAFT HAS CHANGED PLEASE FORWARD TO NEW OWNER

412-050-045-107, will have historical records cards, and meet the intent of this bulletin.]

COMPLIANCE:

Within the next 25 flight hours or no later than 02/28/99 establish a high crosstube takeoff/landing life limit of 10,000 on 412-050-010-101, /-107, /-111 and a 20,000 take off/landing life on P/N 412-050-045-107. | A

Crosstubes for which the number of hours are unknown or where the number of takeoff/landings cannot be determined or estimated, must be replaced within the next 800 takeoff/landings.

Crosstubes that have historical information establishing the number of takeoff/landings greater than 10,000 or 20,000 as applicable must be replaced within 800 takeoff/landings.

DESCRIPTION:

Bell Helicopter Textron has conducted a review of the high aft crosstube assembly in response to reported field failures. Our analysis indicates a takeoff/landing life must be assigned to the **high aft crosstube**. This bulletin established a 10,000

7851 55192 REY 1198

AN APPROPRIATE ENTRY SHOULD BE MADE IN THE AIRCRAFT LOG BOOK UPON ACCOMPLISHMENT
IF OWNERSHIP OF AIRCRAFT HAS CHANGED PLEASE FORWARD TO NEW OWNER

be assigned to the **high aft crosstube**. This bulletin established a 10,000 takeoff/landing life on existing aft crosstube assemblies P/N 412-050-010-101, /-107, /-111 and a 20,000 takeoff/landing limit life on the new high aft crosstube assemblies P/N 412-050-045-107. Operators are also being provided with the information to calculate the number of takeoff/landings. If the total number of takeoff/landings is less than the recommended life, assign serial number (if required) to the high aft crosstube and record all takeoff/landings until appropriate life is achieved.

A

APPROVAL:

The engineering design aspects of this bulletin are {FAA/DER} approved.

MANPOWER:

Approximately 1.0 man-hours are required to complete this bulletin. Man-hours are based on hands-on time, and may vary with personnel and facilities available.

WARRANTY:

Not applicable to Revision A of ASB 412-99-97.

A

Customers with affected (10,000 takeoff/landings) crosstubes are eligible for a special rebate credit as follows.

- Customers with crosstubes, which are less than 2 years old, will receive a rebate for 100% of the replacement tube price.
- Customers with crosstubes, which are between 2 and 4 years old will receive a rebate for 75% of the replacement tube price.
- Customers with crosstubes, which are between 4 and 6 years old, will receive a rebate of 50% of the replacement tube price.
- Customers with crosstubes which are 6 years old or more will receive a rebate for 25% of the replacement tube price.

To receive this special rebate listed above:

- Order the replacement crosstube from an approved Bell Helicopter Textron spares supply source.
- Submit to Bell Helicopter Textron Warranty Administration a completed Malfunction Report within 30 days after accomplishing the Alert Service Bulletin. A copy of the invoice indicating the original purchase of the earlier configuration tube, in the event the tube is original equipment on the aircraft, a statement from the customer attesting to the number of years in service on the earlier configuration tube must be attached to the Malfunction Report.

MATERIAL:

Required Material:

The following material is required for the accomplishment of this bulletin and may be obtained through your Bell Helicopter Textron Supply Center.

<u>Part Number</u>	<u>Nomenclature</u>	<u>Quantity</u>
412-050-045-107	Crosstube	1

-NOTE-

Support beam assembly (rocking beam) P/N 412-050-003-109/111 is not included in crosstube assembly P/N 412-050-045-107. Order crosstube assembly P/N 412-050-045-105 if the support beam is required during replacement. The support beam P/N 412-050-003-ALL remains an on-condition item. The takeoff/landing limits only apply to the crosstube, not the support beam assembly.

| A

SPECIAL TOOLS:

None required

WEIGHT AND BALANCE:

Not affected

ELECTRICAL LOAD DATA:

Not affected

REFERENCES:

BHT-412-IPB Illustrated Parts Breakdown
BHT-412-MM Maintenance Manual
BHT-412-CR&O Component Repair and Overhaul Manual
BHT-ALL-SPM Standards Practice Manual

PUBLICATIONS AFFECTED:

BHT-412-IPB Illustrated Parts Breakdown
BHT-412-MM Maintenance Manual
BHT-412-CR&O Component Repair and Overhaul Manual
BHT-ALL-SPM Standards Practice Manual
BHT-412-SI-60 Service Instruction
BHT-412-SI-2 Service Instruction

A

ACCOMPLISHMENT INSTRUCTIONS:

1. Verify all original crosstubes, P/N 412-050-010-101 (Next Higher Assembly P/N 412-050-011-101), 412-050-010-107 (NHA P/N 412-050-011-105.), 412-050-010-111 (NHA P/N 412-050-011-107) meet the inspection criteria of the applicable Maintenance Manual.

-NOTE-

Only the new generation high aft crosstubes assemblies (P/N 412-050-045-107) have a factory generated part number and serial number located on the crosstube adjacent to the skid tube saddle per Figure 1. The part number vibro-etched in the crosstube is the next lower assembly P/N 412-050-044-103.

-NOTE-

New aft crosstubes, P/N 412-050-044-103, must also meet new damage limits per Table 1 and Figures 2 and 3.

2. Create a Historical Record form to track the applicable high aft crosstube takeoff/landing life per the compliance section of this bulletin. Those operators that have recorded the number of takeoff/landings and have the part number and serial number visible per Figure 1 are subject to the 20,000 takeoff/landing limit.

-NOTE-

Helicopters with takeoff/landings that are higher than the average of 4 per flight must substitute the higher value in all estimated calculations.

3. If the actual takeoff/landing information is not available it is permissible to estimate the number. To determine the number of takeoff/landings on the crosstube, multiply the airframe hours by a factor of four.

4. Place the calculated takeoff/landing information on the Historical Record form and track the applicable life as per the compliance section of the bulletin.
5. Bell Helicopter Textron crosstubes not displaying a visible part number/serial number per figure 1 will be required to be identified as P/N 412-050-011-107FM. Vibro-etch the part number on the crosstube adjacent to the skid tube saddle per figure 1.

-NOTE-

Crosstubes in active service shall have the serial number established corresponding to the helicopter serial number. Crosstubes held as spares stock shall have the serial number assigned by the operator's Quality Assurance Department as indicated. The serial number must be sequentially unique and internally controlled within the company.

6. Vibro-etch a company-controlled serial number below the part-number on the crosstube adjacent to the skid tube saddle per figure 1.

-NOTE-

Support beam (rocking beam) P/N 412-050-003-ALL from the existing installation may be reused as an "on-condition" item. Crosstube assembly P/N 412-050-045-105 comes complete with a new support beam (rocking beam). Order P/N 412-050-045-107 if the rocking beam is not desired.

7. Replace life limited crosstubes per the applicable Maintenance Manual. The new crosstube assembly P/N 412-050-045-107 is a direct replacement for the existing crosstube. This crosstube (P/N 412-050-045-107) requires the support beam to complete the installation on the helicopter. **A**
8. Crosstubes P/N 412-050-045-107 must comply with the damage limits shown in Table 1, Figures 2 and 3. The Maintenance Manual will be revised to show the new damage limits.

-NOTE-

Your new crosstube assembly purchased after the Alert Service Bulletin introduction will come with a Historical Record form to track the 20,000-takeoff/landing life.

A full-length inner and outer shot-peened surface is incorporated on all new high aft crosstubes.

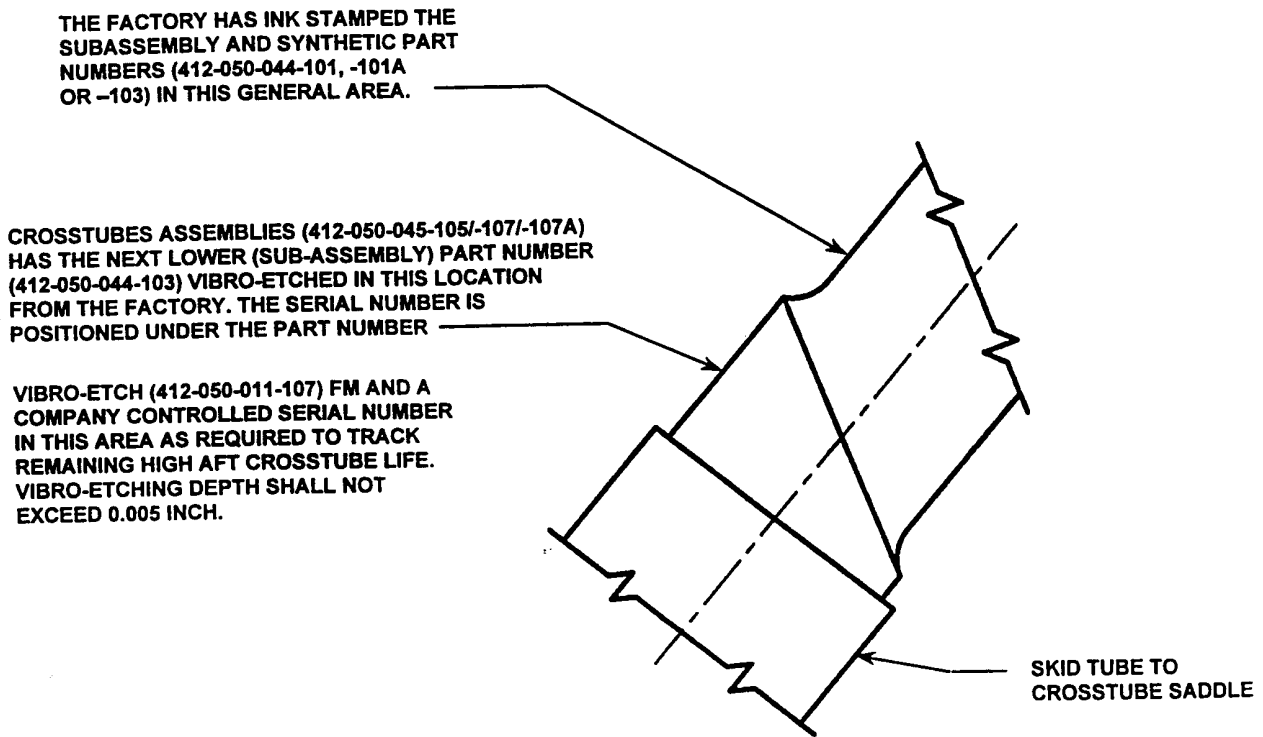



HIGH AFT CROSSTUBE

412ASB-97026-1

FIGURE 1

Damage Limits for High Aft Crosstube P/N 412-050-045-107

TABLE 1	
MAXIMUM ALLOWABLE CLEAN-UP DEPTH	
ZONE 	AFT CROSSTUBE INCHES (MM)
A1	0.005 (0.127)
A2	0.015 (0.381)
A3	0.005 (0.127)
A4	0.015 (*0.381)
B1	0.005 (0.127)
B2	0.015 (0.381)
B3	0.005 (0.127)
B4	0.015 (0.381)
C1	0.012 (0.305)
C2	0.012 (0.305)
C3	0.005 (0.127)
C4	0.012 (0.35)
D 	0.038 (0.965)



See figure 2 for zone definition.

2. All dimensions are in inches (Except at noted).
3. Repairs limited to one repair per “quadrant”, 2 at any cross-section.
4. Log location and depth of all repairs for each cross-tube.
5. Repair limits are lifetime accumulation at any location.
6. Repair in Zone D not to impinge on more than one fastener hole.



Allowable depth of repair is 0.050 inch (1.27 mm) for bottom 0.50 inch (12.7 mm) of area as indicated except within 0.315 inch (8.00 mm) radius of center of any fastener hole. Otherwise, limits for Zone D are as shown in Table 1.



0.050 in. (12.7 mm) maximum damage allowed on first 0.50 inch (12.7 mm) of crosstube except as indicated by note 



Maximum allowable damage in shaded area is determined in zone D inspection limits.

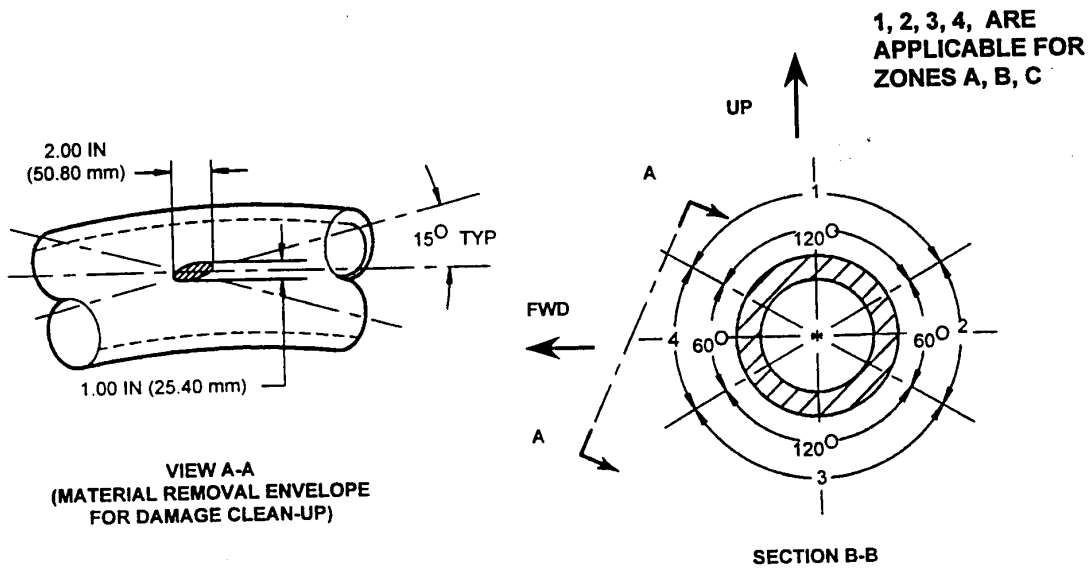
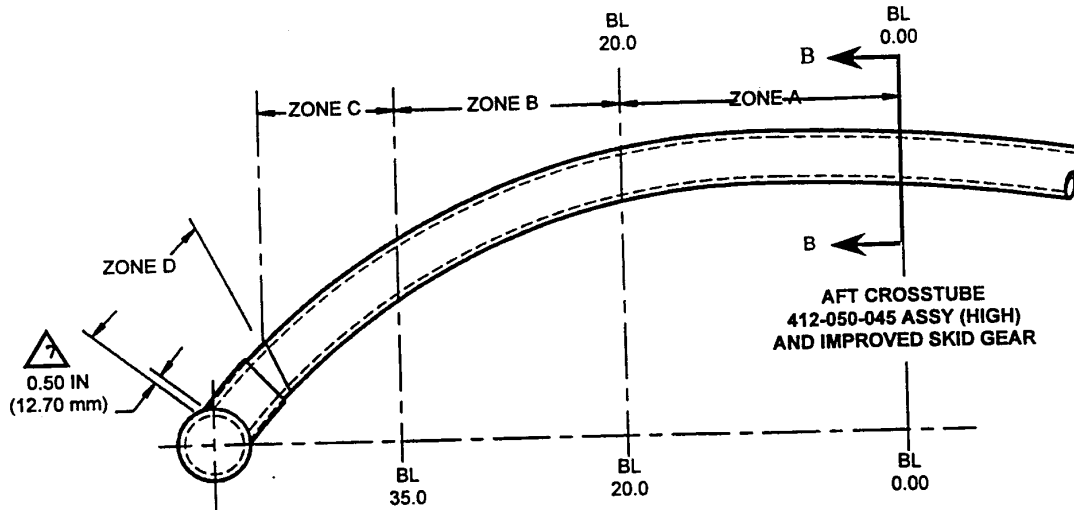

FOR MAX. ALLOWABLE
CLEAN-UP DEPTHS
SEE TABLE 1

FIGURE 2

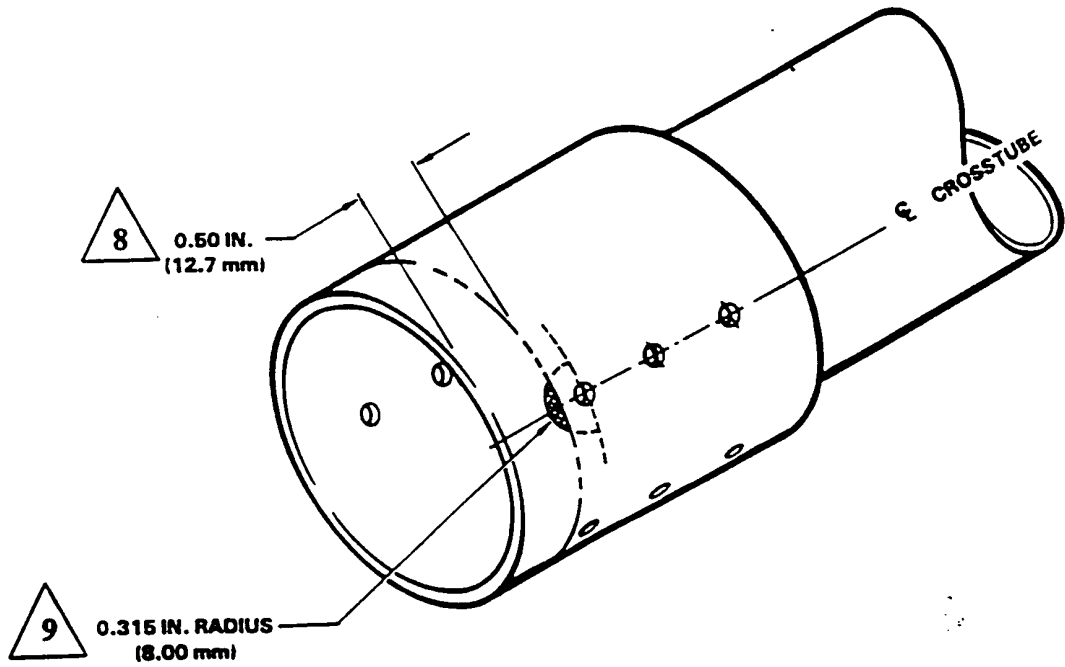

FIGURE 3