

**ALERT SERVICE BULLETIN**  
**Bell Helicopter** **TEXTRON**

A Subsidiary of Textron Inc.

NO. 407-07-79

DATE JUL 19, 2007

PAGE 1 of 7

DATE
REV

**MODEL AFFECTED:** 407

**SUBJECT:** FREEWHEEL AFT SEAL P/N 209-340-265-103,  
INSTALLATION PROCEDURES IMPROVEMENT  
OF

**HELICOPTERS AFFECTED:** 407 helicopters serial number 53000 through 53631  
with TB 407-05-69 accomplished.  
Helicopter serial number 53632 through 53766 that  
had seal installed in production.

Helicopters serial number 53767 and subsequent  
will have the intent of this bulletin accomplished  
prior to delivery.

-NOTE-

This Alert Service Bulletin cancels and supersedes the TB  
407-05-69 dated July 26, 2005.

-NOTE-

COMPLIANCE PART I section of this Alert Service Bulletin  
can be accomplished by the pilot or a licensed mechanic.

**COMPLIANCE:** PART I: Before the first flight of each day following  
receipt of this Alert Service Bulletin.

-NOTE-

Accomplishment of PART II of this bulletin is a terminating  
action to PART I.

PART II: Within the next 50 hours but no later than  
30 days after receipt of this Alert Service Bulletin.

**DESCRIPTION:**

Bell Helicopter has received reports indicating that seal 209-340-265-103 can move outboard from the freewheel aft bearing cap. This condition may lead to an excessive oil leak, which can result in a lack of lubrication at the transmission and the freewheel assembly.

**APPROVAL:**

The engineering design aspects of this bulletin are TCCA approved.

**MANPOWER:**

Approximately 0.1 man-hour is required to complete PART I of this bulletin. Approximately 1.5 man-hours are required to complete PART II of this bulletin. Man-hours are based on hands-on time, and may vary with personnel and facilities available.

**WARRANTY:**

Owners / Operators of Bell 407 Helicopters who comply with the instructions in this Bulletin will be eligible to receive a credit for the replacement parts outlined under the required material section.

To receive this credit:

- Purchase the required parts from a BHT supply source.
- Comply with the instructions contained in this Bulletin no later than the applicable hours in the “compliance section” of this ASB, or before 31 December 2008.
- Submit an MMIR to the Bell Warranty Department for the replacement parts.
- There is no labor cost provided with this Bulletin.

**MATERIALS:**

The material that follows is required to do this bulletin and can be obtained through your Bell Helicopter Textron Supply Center.

<b><u>Part Number</u></b>	<b><u>Nomenclature</u></b>	<b><u>Quantity</u></b>
209-340-265-103	SEAL	1

**Consumable Material:**

The following material is required to accomplish this bulletin, however this material is considered consumable (bench stock) material and may not require ordering depending on the operators consumable material stock levels. This material may be obtained through your Bell Helicopter Textron Supply Center.

<b>Part Number</b>	<b><u>Nomenclature</u></b>	<b><u>Reference</u></b>
ACETONE GALLON	SOLVENT	C-316
AMS 3284	SEALANT	C-328

**SPECIAL TOOLS:**

Not required

**WEIGHT AND BALANCE:**

Not affected

**ELECTRICAL LOAD DATA:**

Not affected

**REFERENCES:**

BHT-407-MM, Revision 23, June 07, 2006.  
Chapter 63, Main Rotor Drive

**PUBLICATIONS AFFECTED:**

BHT-407-MM, Revision 23, June 07, 2006.  
Chapter 63, Main Rotor Drive

BHT-407-CR&O, Revision 1, February 02, 2007.  
Chapter 63-30, Drive System Freewheel

TB 407-05-69, July 26, 2005.

**ACCOMPLISHMENT INSTRUCTIONS:**

**PART I: Recurring check before the first flight of each day.**

**-NOTE-**

This check can be accomplished by the pilot or a licensed mechanic. If PART II of this bulletin is accomplished, compliance with PART I is terminated.

1. Open left hand side engine door.
2. Visually inspect seal for proper installation. Refer to figure 1.
  - a. If the seal (1, figure 1) is flush or protruding from the freewheel aft bearing cap (2), do PART II before next flight.
  - b. If seal (1) is installed correctly, continue to perform PART I of this bulletin until PART II is accomplished.
3. Make a log book entry to show that the PART I of this Alert Service Bulletin has been accomplished.

**PART II: Installation procedures for seal 209-340-265-103.**

1. Remove the aft bearing cap (2, figure 2) (BHT-407-MM, Chapter 63).
2. Remove and discard the existing seal (1) (BHT-407-MM, Chapter 63).
3. Install the new seal as follows:
  - a. Clean the aft bearing cap (2) and the outside diameter of the seal (1) with solvent (C-316).
  - b. Apply sealant (C-308) to the outer diameter of the seal (1).

**CAUTION**

DO NOT USE A HYDRAULIC PRESS TO INSTALL THE SEAL. USE A MANUAL ARBOR PRESS TO CONTROL THE FORCE APPLIED ON THE SEAL FACE.

- c. While sealant is wet and using work aid (figure 2) push the seal (1) into the aft bearing cap (2) evenly and smoothly until seated.
- d. Fair the squeeze out of sealant (C-308) as shown in figure 2.
4. Complete the installation of the freewheel assembly (BHT-407-MM, Chapter 63) and allow time to cure the sealant (C-308) prior to ground run.
5. Perform a ground run for 5 minutes at 100% NR and inspect for leaks.
6. Make a log book entry to show that the PART II of this Alert Service Bulletin has been accomplished.



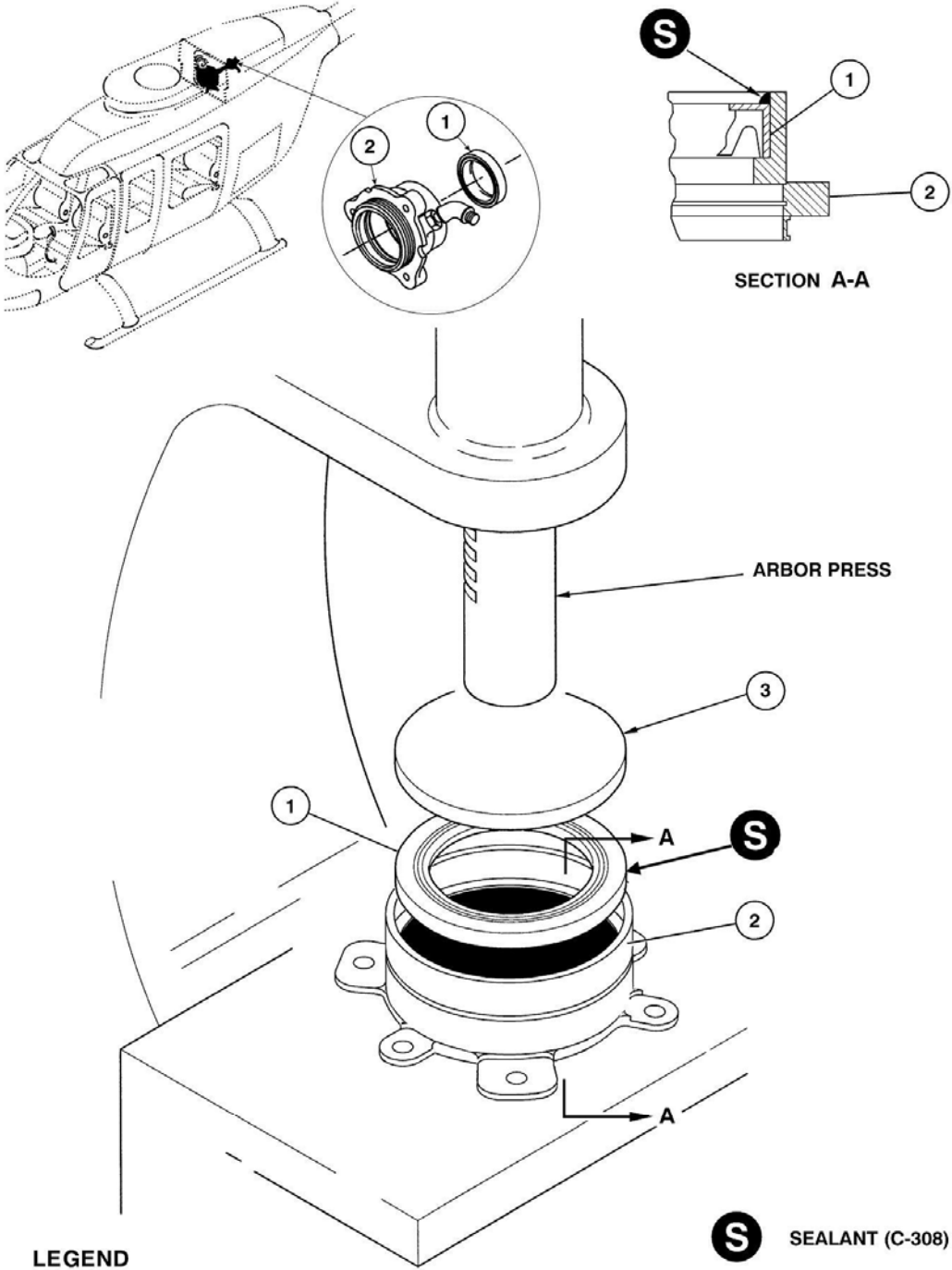

**LEGEND**

- 1. Freewheel aft seal (209-340-265-103)
- 2. Freewheel aft cap (406-040-509-101)
- 3. Workaid item #5 (BHT-407-CR&O)

**S** SEALANT (C-308)

04594001

**Figure 2. Installation procedures for seal 209-340-265-103**