

ALERT SERVICE BULLETIN
REVISION NOTICE

DATE Dec 08, 2008



TO: All Owners/Operators of Bell 205A & 205A-1 Helicopters

**SUBJECT: REVISION "A" TO ALERT SERVICE BULLETIN 205-07-94:
(STARTER/GENERATOR POWER CABLE UPGRADE)**

Revision "A" to this bulletin is to incorporate minor changes into the text for better comprehension, also to make a correction to the kit part list by adding a missing nut and two missing washers. Please note that the intent of the bulletin did not change. Consequently, no action is required on aircraft already modified per the original release of this bulletin.

AN APPROPRIATE ENTRY SHOULD BE MADE IN THE AIRCRAFT LOGBOOK UPON ACCOMPLISHMENT
IF OWNERSHIP OF AIRCRAFT HAS CHANGED PLEASE FORWARD TO NEW OWNER

ALERT SERVICE BULLETIN



NO. 205-07-94

DATE June 01, 2007

PAGE 1 of 7

DATE	Dec 08, 08
REV	A

MODEL AFFECTED: 205A & 205A-1

SUBJECT: STARTER/GENERATOR POWER CABLE, UPGRADE.

HELICOPTERS AFFECTED: Model 205A & 205A-1 helicopters serial number 30001 through 30332.

COMPLIANCE: 1 year from release date of this bulletin.

DESCRIPTION:

Bell Helicopter has been made aware of a possibility of fire hazard caused by the starter/generator power cable shorting out at connector P81 (J81) pins. This ASB addresses this issue by replacing the affected cable assemblies.

APPROVAL:

The engineering design aspects of this bulletin are FAA/DER approved.

MANPOWER:

Approximately 10.0 man-hours are required to complete this bulletin. Man-hours are based on hands-on time, and may vary with personnel and facilities available.

WARRANTY:

Owners / Operators of Bell 205A-205A1 Helicopters who comply with the instructions in this Bulletin will be eligible to receive a 100% credit for the replacement parts Kit CT205-07-94-1 outlined under the required material section.

To receive this credit:

- Purchase the required kit CT205-07-94-1 from a BHT supply source.
- Comply with the instructions contained in this Bulletin no later than the applicable hours or date listed in the “compliance section” of this ASB.
- Submit an MMIR to the Bell Warranty Department for the replacement parts.

-NOTE-

Customers who fail to comply with the instructions in this Bulletin after one year from date of release of this Bulletin are not eligible for the special warranty credit provisions listed above. No labor cost will be covered under this bulletin.

MATERIAL:

Required Material:

The following material is required for the accomplishment of this bulletin and may be obtained through your Bell Helicopter Textron Supply Center.

<u>Part Number</u>	<u>Nomenclature</u>	<u>Quantity</u>
CT205-07-94-1	Starter/generator cable kit	1

Note: The Starter/generator cable kit consists of the following parts:

205-075-265-103	Cable Assembly	1
205-075-265-105S	Cable Assembly	1
MS27212-5-2	Terminal Board	1
MS18029-5S2	Cover	1
MS3373-A3	Insulating strip	1
MS3373-C3	Insulating strip	1
31-034-1-150	Tape	1
80-011-P7F0-0	Plug	3
80-011-S7D08-0	Sleeve	3
MS21042L6	Nut	1
AN960D616L	Washer	2

Consumable Material:

The following material is required to accomplish this bulletin, but may not require ordering, depending on the operator's consumable material stock levels. This material may be obtained through your Bell Helicopter Textron Supply Center.

<u>Part Number</u>	<u>Nomenclature</u>	<u>Quantity</u>	<u>Reference</u>
299-947-100, type II, class 2	Adhesive	A/R	C-317
MIL-S-81733 type 2	Sealant	A/R	C-251

SPECIAL TOOLS:

<u>Part Number</u>	<u>Nomenclature</u>	<u>Quantity</u>
MS 25441 (or equivalent)	Crimper	1
MS 23002-1 (or equivalent)	Die	1

A

ELECTRICAL LOAD DATA:

Not affected

REFERENCES:

BHT-205-IPB Illustrated Parts Breakdown
 BHT-205-MM Maintenance Manual
 BHT-MED-SRM-1 Structural Repair Manual
 BHT-ELECT-SPM Electrical Standard Practice Manual

A

PUBLICATIONS AFFECTED:

BHT-205-IPB Illustrated Parts Breakdown
 BHT-205-MM Maintenance Manual

ACCOMPLISHMENT INSTRUCTIONS:

- 1) Prepare helicopter for maintenance.
- 2) Remove and discard cable assembly 205-075-902-017 using following steps:
 - a) Gain access to connector P81 located on the left hand side engine deck.

- b) Disconnect connector P81 from J81 and disconnect wires at starter/generator terminals E, B, and C. Retain hardware for re-installation.

- 3) Remove and discard cable assembly 205-075-911-007 using following steps:

-NOTE-

Note cable routing and clamping when removing cables, and use similar routing and clamping when installing the new cables.

- a) Gain access to connector J81 located underneath the left hand side engine deck.
 - b) Remove connector J81 from lower engine deck panel. Retain attaching hardware for re-installation.
- 4) Remove wires as per Table 1. Retain hardware for re-installation.
 - 5) Install plugs and sleeves as follow:
 - a) Locate qty 3 holes in accordance with Figure 1.
 - b) Drill qty 3 holes 0.296 to 0.289 inch through panel assembly as shown on figure 1.
 - c) Install qty 3 sleeves P/N 80-011-S7D08-0 far side and plug P/N 80-011-P7F0-0 using adhesive C-317 as detailed in Structural Repair Manual (SRM).
 - d) Allow adhesive to cure.
 - 6) Install terminal board P/N MS27212-5-2, TB 150, on inboard side of main beam at STA 205.10 using qty 3 screws MS35206-233, qty 3 washers AN960PD6L, and qty 3 nuts NAS679A06.
 - 7) Install identification tape P/N 31-034-1-150 beside terminal board and apply sealant C-251 over tape.
 - 8) Install cable assembly P/N 205-075-265-105 connector J81 on lower side of engine deck using retained hardware.

-NOTE-

Reference to Figure 2 for the following steps.

- 9) Prepare ground pad for electrical bonding per BHT-ELECT-SPM. Connect wire P73B1N to ground pad using retained hardware.

- 10) Connect wire P95B1 to K57 (starter relay) terminal A2 using retained hardware.
- 11) Connect wire P72B1 and P72C1 to TB 150, terminal 1 using strip P/N MS3373-A3, strip P/N MS3373-C3, qty 2 washer P/N AN960D616L and nut P/N MS21042L6.
- 12) Install cover assembly P/N MS18029-5S-2 on TB 150.
- 13) Connect the other end of wire P72C1 to R1 (Generator Shunt) on the + side as follows:
 - a) Route wire P72C1 to R1 (Generator Shunt).
 - b) Cut wire P72C1 and install terminal lug P/N MS25036-130 using crimper p/n MS 25441 with die p/n MS23002-1.
 - c) Connect wire P72C1 to R1 (generator Shunt) on + side using retained hardware.
- 14) Install cable assembly P/N 205-075-265-103 by connecting P81 to J81 and safety with lockwire.
- 15) Perform continuity check using multimeter as follow:
 - a) Check continuity between end of wire P73A1 and ground. Reading should be approximately 0 ohms.
 - b) Check continuity between end of wire P72A1 and R1, + side (generator shunt). Reading should be approximately 0 ohms.
 - c) Check continuity between end of wire P95A1 and K57 terminal A2 (starter relay). Reading should be approximately 0 ohms.
- 16) Connect wires to G6 (starter generator)
 - a) Connect wire P73A1 to G6 (starter generator) terminal E using retained hardware.
 - b) Connect wire P72A1 to G6, terminal B using retained hardware.
 - c) Connect wire P95A1 to G6, terminal C using retained hardware.
- 17) Make helicopter safe for flight.
- 18) Make an entry in helicopter historical record indicating compliance with this Alert Service Bulletin.

Wire number	From connection	Pin
K5B0N	GROUND PAD	N/A
K5D4N	GROUND PAD	N/A
P37D4	GENERATOR SHUNT R1	+ SIDE
P37B0	GENERATOR SHUNT R1	+ SIDE
K6C4	STARTER RELAY AFT K57	A2
K6A4	STARTER RELAY AFT K57	A2

Table 1
Remove wires

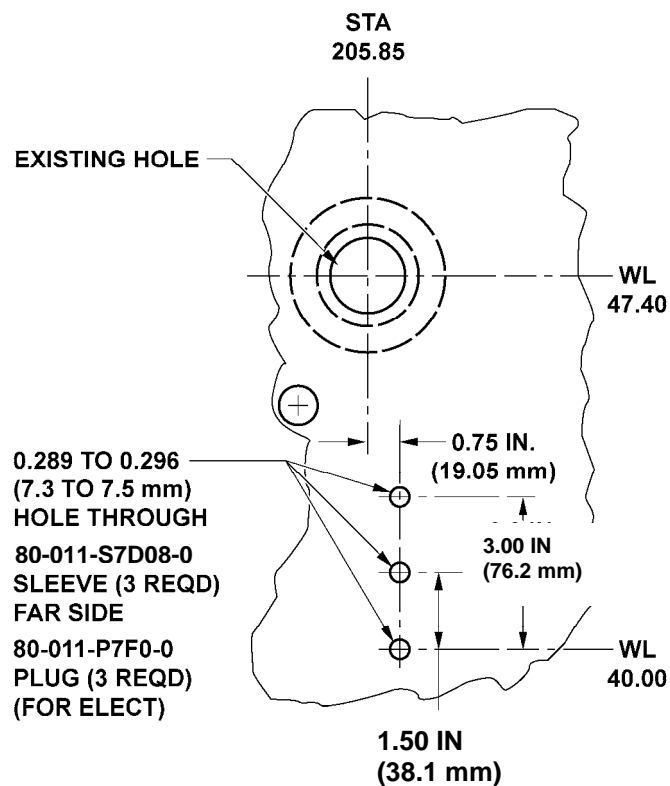

VIEW LOOKING OUTBOARD AT
LEFT-HAND MAIN BEAM
STA 205.85

06601_001

Figure 1
Structural Modification

