

ALERT SERVICE BULLETIN



NO. 205-09-101

DATE Sept 24, 2009

PAGE 1 of 6

DATE
REV

MODEL AFFECTED: 205A & 205A-1

SUBJECT: 205-030-856-157/-159 ELEVATORS, ONE TIME INSPECTION OF.

HELICOPTERS AFFECTED: Model 205A & 205A-1 helicopters with 205-030-856-157/-159 elevators, s/n A-1587 through A-1862 installed.

COMPLIANCE: Within 100 flight-hours but no later than 12 months after release of this bulletin.

DESCRIPTION:

There is a built-in angle difference of 1.00 +/- 0.50 degrees between the LH and RH Elevators on the aircraft. Bell Helicopter has learned that some p/n 205-030-856-157/-159 elevators were incorrectly assembled at manufacture. Due to tooling discrepancies, some elevators could have an offset exceeding the angle tolerance. This bulletin explains how to measure the angles to detect discrepant elevators. This angle must be measured while the elevator(s) is (are) installed on the aircraft. Because of the drawing tolerances, the RH Elevator Assy must be good in order to confirm the condition of the LH Elevator. For this reason, this bulletin has been divided in two parts, between which the aircraft may be released for flight, while the parts are procured.

APPROVAL:

The engineering design aspects of this bulletin are FAA/DER approved.

MANPOWER:

Approximately 1.0 man-hour is required to complete this bulletin. Man-hours are based on hands-on time, and may vary with personnel and facilities available.

WARRANTY:

Owners / Operators of Bell Helicopters who comply with the instructions in of this Bulletin will be eligible to receive a one time credit towards the cost of replacement elevator part number 205-030-856-157 or 205-030-856-159.

To receive this credit:

- Comply with the instructions contained in this Bulletin no later than the applicable hours in the “compliance section” of this ASB, or before September 24, 2010.
- Purchase a replacement elevator from a Bell approved source.
- Submit an MMIR to the Bell Warranty Department referencing this ASB.

Customers who fail to comply with the instructions in this Bulletin before September 24, 2010 are not eligible for the special warranty credit listed above. There is no labor associated with this bulletin.

MATERIAL:

Required Material:

The following material is required for the accomplishment of this bulletin and may be obtained through your Bell Helicopter Textron Supply Center.

<u>Part Number</u>	<u>Nomenclature</u>	<u>Quantity</u>
205-030-856-157	Elevator	A/R
205-030-856-159	Elevator	A/R

SPECIAL TOOLS:

Lucas Anglestar DP45 Digital Protractor or equivalent

WEIGHT AND BALANCE:

Not affected

ELECTRICAL LOAD DATA:

Not affected

REFERENCES:

BHT-205-IPB Illustrated Parts Breakdown
BHT-205-MM Maintenance Manual

PUBLICATIONS AFFECTED:

None affected

ACCOMPLISHMENT INSTRUCTIONS:

Part I

1. Prepare helicopter for maintenance.
2. Confirm any of the elevators are within serial number range by referring to their bonded and riveted dataplate near the trailing edge.
3. Remove tailboom belly access panel just aft of Boom Station (BS) 101.38.
4. Using a measuring tape, position center of elevator horn control bolt at 38.91 +/- 0.03 inches (989.8 +/- 0.8 mm) from (and perpendicular to) the aft face of bulkhead at BS 101.38. Refer to Figure 1. Move cyclic controls as required and apply cyclic control friction when done.
5. Place digital protractor on aft face of bulkhead at BS 101.38. Zero protractor.
6. Move protractor to top skin of RH elevator second rib, edge of protractor should be aligned with the 8th rivet from the leading edge of the elevator. Record relative angle as Angle "A". Zero protractor.

-NOTE-

Digital Protractor must be located and installed on the L/H elevator exactly in the same direction and location as positioned on the R/H elevator.

7. Move protractor to top skin of L/H Elevator and record the angle as Angle "B".
8. The correct value for Angle A is 0.00 +/- 0.50 degree. The correct value for Angle B is 1.00 +/- 0.50 degree.
 - a. If Angle "A" and Angle "B" are not within their applicable tolerance, replace the RH elevator as per Maintenance Manual within the next 100 flight-hours and proceed to Part II thereafter.
 - b. If Angle "A" is not within its applicable tolerance but Angle "B" is within its applicable tolerance, replace the RH elevator as per Maintenance Manual within the next 600 flight-hours and proceed to Part II thereafter.
 - c. If Angle "A" is within its applicable tolerance but Angle "B" is not within its applicable tolerance, replace LH elevator as per Maintenance Manual within the next 100 flight-hours. No further action is required. Go to Part II, step 6.
 - d. If Angle "A" and Angle "B" are both within their applicable tolerance, both elevators are compliant and no further action is required. Go to Part II, step 6.
9. Make an entry in helicopter historical records indicating compliance with Part I of this bulletin.

Part II

1. When replacement of RH elevator has been accomplished, make helicopter ready for maintenance, if not previously accomplished since last flight.

-NOTE-

For Part II, there is no requirement to position the elevator horn as described in Part I, step 4 above. Digital Protractor must be located and installed on the L/H elevator exactly in the same direction and location as positioned on the R/H elevator.

2. Place protractor to top skin of RH elevator second rib, edge of protractor should be aligned with the 8th rivet from the leading edge of the elevator. Zero the digital protractor.

3. Move protractor to top skin of L/H Elevator and record relative angle as Angle "B".
4. The tolerance for Angle B is 1.00 +/- 0.50 degrees. If the angle is not within applicable tolerance, replace the LH elevator as per Maintenance Manual within the next 100 flight-hours.
5. Re-install access panels and make helicopter ready for flight.
6. Make an entry in helicopter historical records indicating compliance with Part I and II of this bulletin.

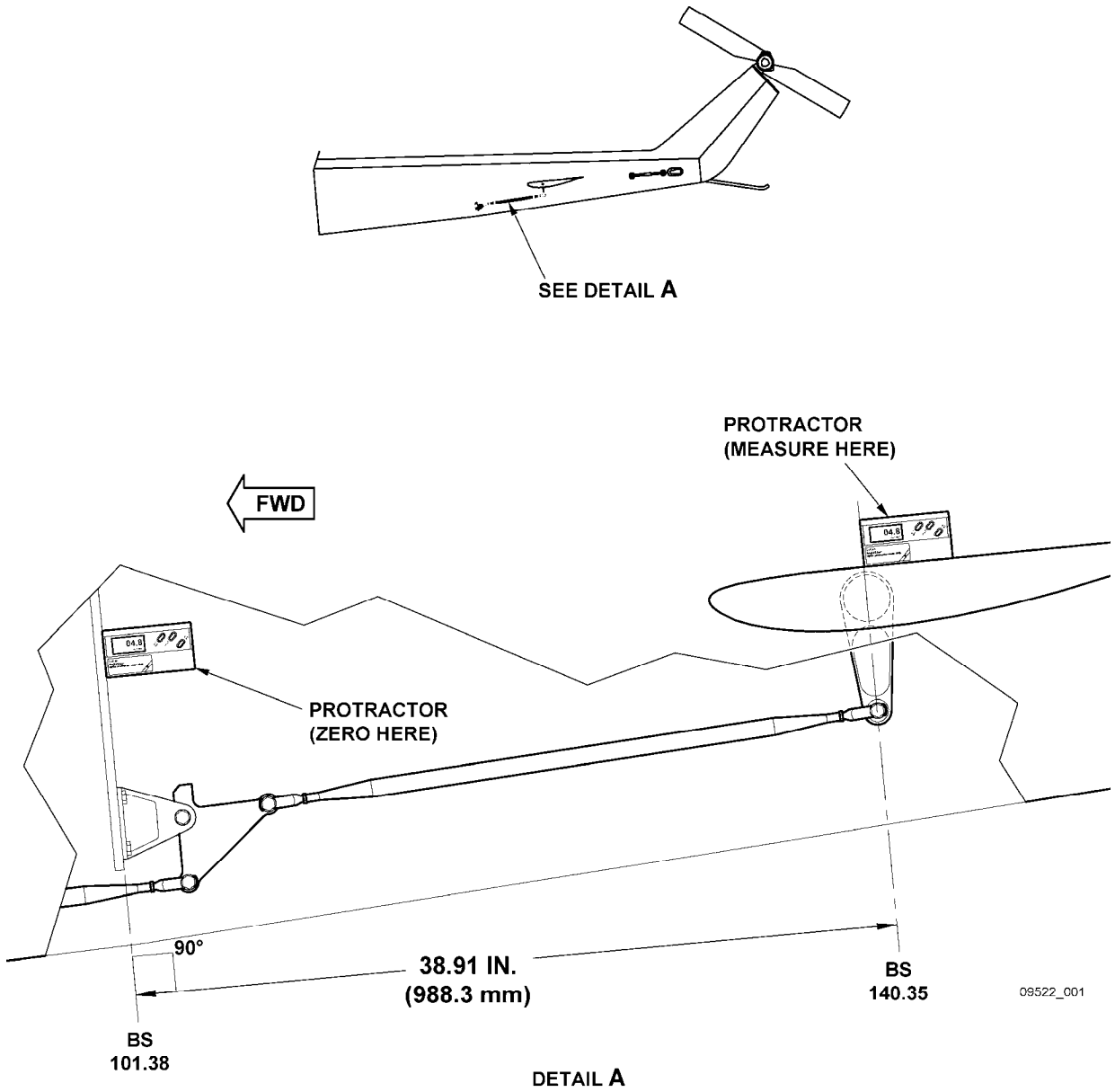

Figure 1
Angle Measurements