

**ALERT SERVICE BULLETIN**



A Textron Company

NO. 205-10-106

DATE June 23, 2010

PAGE 1 of 12

DATE
REV

**MODEL AFFECTED:** 205A /205A-1

**SUBJECT:** HIGH FORWARD CROSSTUBES, P/N 205-050-403-031, 412-050-046-101, MANDATORY INSPECTION

**HELICOPTERS AFFECTED:** Model 205A and 205A-1 helicopters serial numbers 30001 through 30039, 30050 through 30052, 30057 through 30067, 30078 through 30127 and 30128 through 30332.

[The intent of this bulletin will be incorporated into the Model 205A1 Maintenance Manual at a future date.]

**COMPLIANCE:** Within 6 months after receipt of this bulletin.

Part I

Schedule and accomplish a recurring 12 month / 5000 landing Fluorescent Penetrant Inspection of forward high crosstube.

Part II

Schedule and accomplish a recurring 12 month / 2500 landing Deflection Check of the forward high crosstube

**DESCRIPTION:**

Bell Helicopter has completed an analysis of the high forward crosstubes, as a result of reported field failures. Our results indicate repetitive cycle fatigue and corrosion related damage is occurring. These results warrant a 12 month / 5000 landing repetitive Fluorescent Penetrant Inspection and Deflection Check.

**APPROVAL:**

The engineering design aspects of this bulletin are FAA/ODA approved.

**MANPOWER:**

Approximately 8.0 man-hours are required to complete this bulletin. Man-hours are based on hands-on time, and may vary with personnel and facilities available.

**WARRANTY:**

There is no warranty provided for this bulletin.

**MATERIAL:**

**Required Material:**

The following material is required for the accomplishment of this bulletin and may be obtained through your Bell Helicopter Textron Supply Center.

<u>Part Number</u>	<u>Nomenclature</u>	<u>Quantity</u>
206-050-301-109	Abrasion Strip	AR
CR4622CW-6-8	Rivets	AR
412-050-038-103	Support	AR

**Consumable Material:**

The following material is required to accomplish this bulletin, but may not require ordering, depending on the operator's consumable material stock levels. This material may be obtained through your Bell Helicopter Textron Supply Center.

<u>Part Number</u>	<u>Nomenclature</u>	<u>Quantity</u>	<u>Reference</u>
AMS-S-8802	Sealant	1	C-308
299-947-320 Class 1	Adhesive Primer	AR	C-253
299-947-320 Type 1	Adhesive Film	AR	C-252
L100	Larson Adhesive	AR	C-571
MIL-R-81294	Paint Remover	AR	C-436*
MS-242-N	Quik-Freeze	AR	C-137
299-947-100TY2CL2PT	Adhesive	AR	C-317
MIL-PRF-23377, TY1	Primer	AR	C-204

\* Customers may also use Turco 5351(T-5469)

**SPECIAL TOOLS:**

None required

**WEIGHT AND BALANCE:**

Not Affected

**ELECTRICAL LOAD DATA:**

Not affected

**REFERENCES:**

BHT-205-IPB Illustrated Parts Breakdown  
BHT-205A1-MM Maintenance Manual  
BHT-ALL-SPM  
BHT ASB 205-09-100 Rev A (AAI ASB AA-08055, Rev B)

**PUBLICATIONS AFFECTED:**

BHT-205-SI-35 High Skid Gear / High Crosstube

**ACCOMPLISHMENT INSTRUCTIONS**

**ESTABLISHING REQUIREMENTS:**

1. Review the high landing gear forward crosstube component history information or helicopter log book and determine bulletin applicability as indicated in Table 1 below.

**TABLE 1**

Crosstube Assembly Part Number	Crosstube sub-assembly (Non-procurable) (See note)
205-050-403-031	205-050-403-035
412-050-046-101	412-050-047-101

Note: Sub-assemblies are indicated above for tracking purposes.

Note: Use AAI ASB AA-08055, Rev B (BHT ASB 205-09-100 Rev A) when using AAI manufactured forward crosstube P/N 212-321-103

**-NOTE-**

High forward crosstubes assemblies P/N 205-050-403-031 are identified by the use of a decal at BL 0.0 lower side, see Figure 1. If this decal is no longer legible or is missing, determine crosstube part number using helicopters records.

High forward crosstubes assemblies P/N 412-050-046-101 have a part number that is vibro-etched on the crosstube adjacent to the skid tube saddle as indicated in Figure 2.

2. Create a Historical Record form to track the reoccurring maintenance requirements of this bulletin.

**-NOTE-**

Crosstubes in active service shall have the company controlled serial number established corresponding to the helicopter serial number. Crosstubes held as spare stock shall have the company controlled serial numbers assigned by the operators Quality Assurance Department as indicated. The serial number must be sequentially unique and internally controlled within the company.

3. Bell Helicopter Textron crosstubes not clearly displaying a visible part and serial number are required to be identified. The part and serial numbers are to be vibro-etched on the crosstube adjacent to the skid tube saddle as indicated in Figure 2. Vibro-etching depth of this information shall not exceed 0.005inch and shall be accomplished as indicated.

A) Crosstubes using a two piece saddle arrangement (P/Ns, 205-050-132-001, 205-050-133-001) are to indicate P/N 205-050-403-031FM and a company controlled serial number.

B) Crosstubes using the single upper saddle ( P/N 412-050-038-101) that is riveted to the crosstube and a lower composite film abrasion strip (206-050-301-109) shall indicate P/N 412-050-046-101FM and a company controlled serial number.

## **ACCOMPLISHMENT INSTRUCTIONS**

### **PART I - Accomplish a reoccurring 12 month / 5000 landing aft crosstube Fluorescent Penetrant Inspection as indicated below.**

**-NOTE-**

Landing cycle compliance frequency differs between Part I and Part II

**-NOTE-**

The high forward crosstube Fluorescent Penetrant Inspection can be accomplished by any person meeting the personnel Qualification / Certification Requirements of the BHT-ALL-SPM (ref. Chapter 6, Section 6-5).

1. Remove the high landing gear assembly from the helicopter per the BHT-205A1-MM.

### **CAUTION**

TEMPORARILY INSTALLING A SECONDARY LANDING GEAR OR MAINTAINING A CONNECTION TO AN OVERHEAD CRANE IS RECOMMENDED DURING THIS MAINTENANCE ACTION.

2. Remove the high forward crosstube from the landing gear assembly as per BHT-205A1-MM.
3. Remove the hardware from U Bolts P/N 205-050-134-001 retaining BL 14 supports P/N 205-050-132-001 and 205-050-133-001 on forward crosstube P/N 205-050-403-031.
4. Remove sealant from edge of supports P/N 205-050-132-001 and 205-050-133-001 on crosstube 205-050-403-031 using an acrylic or similar scraper.

**CAUTION**

CROSSTUBE TEMPERATURE NOT TO EXCEED 200°F (93.3°C) WHEN USING HEAT GUN. EXCESSIVE HEAT WILL DAMAGE CROSSTUBE.

5. Using a heat gun soften sealant AMS-S-8802 bonding the supports to the crosstube. Separate the clamps from the crosstube.

**CAUTION**

The holes used to attach supports P/N 412-050-038-101 in crosstubes P/N 412-050-046-101 are cold worked. Damage beyond 0.005 inch deep will require a damage assessment. Damage description can be sent to Product Support for review.

6. Removal of upper supports P/N 412-050-038-101 from 412-050-046-101 crosstube is required only if signs of a degraded bond line or working rivets indicate further maintenance investigation is necessary.
7. If necessary remove support P/N 412-050-038-101 by removing the rivets P/N CR4622CW-6-8. If the support is still partially bonded to the crosstube it may be necessary to apply Quik-Freeze (C-137) to the support and tap with a plastic mallet to break the bond line.

**-NOTE-**

Only forward crosstubes 412-050-046-101 have abrasion strips 206-050-301-109 bonded to the under side of the crosstube at BL 14 with the Larson L100. If abrasion strips must be removed, use a plastic scraper to separate the strip from the crosstube while warming and then cooling the area to marginally de-grade the bond line

**CAUTION**

Refer to the manufacture's instructions for proper use of cooling agent (C-137). The agent can reach -55° F (-48° C). Wear protective gloves and eye protection.

8. Remove abrasion strip P/N 206-050-301-109 from crosstube lower BL 14 surface only if the bond line has degraded or if further maintenance actions are required, as per BHT-212-MM.

## **CLEANING AND PREPARATION**

1. Use a plastic scraper to remove residual sealant on the crosstube. Removal of the sealant bead around the periphery of upper supports or lower surface abrasion strips on crosstube 412-050-046-101 is not required.

### **CAUTION**

USE CARE TO PREVENT CONTAMINATION FROM THE PAINT REMOVER CHEMICALS ON THE UPPER SUPPORTS AND ABRASION STRIPS FORWARD CROSSTUBE 412-050-046-101.

2. Prepare crosstube for the inspection process by removing the paint on the crosstube.
  - a. Crosstube P/N 205-050-403-031 will require the exterior paint to be completely removed as indicated in Figure 3. The supports P/N 205-050-132-001 and 205-050-133-001 are removed for this step, as previously indicated.
  - b. Crosstube P/N 412-050-046-101 will require the exterior paint to be removed with the exception of the BL 14 area at the upper supports and lower abrasion strips, which are to be protected as indicated in Figure 4.
3. Apply chemical paint remover (C-436) to the crosstube with a brush following manufacturer's directions and the BHT-ALL-SPM.

### **CAUTION**

A PLASTIC SCRAPER OR ABRASIVE PAD (C-407) MAY BE USED TO GENTLY ASSIST THE PAINT REMOVAL PROCESS. USE OF THE PLASTIC SCRAPER OR ABRASIVE PAD IS TO BE ACCOMPLISHED IN A LONGITUDINAL DIRECTION ENSURING NOT TO ABRASE THE CROSSTUBE METAL SURFACE.

4. Reapply the paint remover as required to completely remove the paint and primer.

5. Rinse crosstube surface clean using potable water and dry thoroughly. Inspect crosstube to ensure the bare metal of the crosstube is clearly visible and free of paint and primer residue in the affected area.
6. Protect crosstube immediately after cleaning with preservative oil (C-125) if the inspection process is delayed. Wrap in barrier material and secure with tape.

## **INSPECTION**

### **CAUTION**

USE CARE TO PREVENT CONTAMINATION FROM FLUORESCENT PENETRANT CHEMICALS ON THE ABRASION STRIPS AND UPPER / LOWER SUPPORT (BL14, BL 00) AS APPLICABLE.

### **-NOTE-**

The high forward crosstube Fluorescent Penetrant Inspection can be accomplished by any person meeting the personnel Qualification / Certification Requirements of the BHT-ALL-SPM (ref. Chapter 6, Section 6-5).

1. Inspect the crosstube, with the exception of the areas covered by the protective abrasion strips and upper support (412-050-046-101) using Fluorescent Penetrant method per ASTM E1417, Type 1 Method B, C or D using a penetrant sensitivity level of 2 or 3 (Refer to BHT-ALL-SPM Chapter 6).
2. All penetrant inspection materials utilized shall be compatible, and shall meet requirements of SAE AMS 2644.

### **-NOTE-**

The use of visible dye systems is prohibited.

3. Inspect crosstube damage per limits specified in the Maintenance Manual (BHT-205A1-MM, Chapter 32) to determine allowable damage and cleanup. No cracks are permitted. To determine the appropriate Inspection Criteria Table in the Maintenance Manual for a specific high forward crosstube, refer to cross reference Table 2 below.

**TABLE 2**

Crosstube Assembly Part Number	Sub Assembly Crosstube Part Number	Crosstube using Standard Inspection Criteria	Crosstube using Improved Inspection Criteria
205-050-403-031		X	
412-050-046-101			X
212-321-103			X See AAI ASB AA-08055 / BHT ASB 205-09-100 Rev A

4. Inspect supports 205-050-134-001 and 205-050-133-001 for serviceability BHT-205A1-MM.
5. Inspect support 412-050-038-101 for corrosion and mechanical damage as per maintenance manual. Removal of the composite film on the inside diameter of the support is only required if the composite film is completely worn through or if further maintenance related investigation is deemed necessary.

## **REPAIR**

1. Repair all damaged crosstubes that are found to be within acceptable limits as indicated in BHT-205-MM Standard or Improved inspection criteria Tables, record all repairs.
2. Replace crosstubes that are beyond the maximum allowable damage limits as indicated in the inspection criteria Tables.

## **REWORK OF CROSSTUBES**

1. Apply primer (C-246) to areas where paint / primer has been removed for inspections per Standard Practice Manual.
2. Install the two-piece supports 205-050-134-001 and 205-050-133-001 on forward crosstube 205-050-403-031 / 031FM as BHT-205A1-MM.
3. Install existing one-piece support 412-050-038-101 on forward crosstube 412-050-046-101 as indicated the maintenance manual. Support 412-050-038-101 has been replaced by 412-050-038-103. The -103 support has the adhesive film already bonded to the inner surface. Install the 412-050-038-103 support as indicated in the manual omitting the step applying the adhesive film to the inner

surface of the support. This support is supplied with a protective film over the adhesive film that must be removed prior to installation on the crosstube.

4. Repaint crosstube as per BHT-ALL-SPM.
5. Annotate helicopter / component records to indicate Part 1 of this bulletin has been accomplished.

## **ACCOMPLISHMENT INSTRUCTIONS**

### **PART II - ACCOMPLISH A FWD CROSSTUBE DEFLECTION CHECK AND ESTABLISH A RECURRING 12 MONTH / 2500 LANDING DEFLECTION CHECK (WHICH EVER COMES FIRST)**

#### **Note**

Deflection check has a lower cycle compliance frequency when compared to the fluorescent penetrant inspection

#### **CAUTION**

**ENSURE HELICOPTER IS STABILIZED ON JACKS  
BEFORE PROCEEDING WITH MEASUREMENTS**

1. Hoist or jack the helicopter until the weight is removed from the landing gear.
2. Determine the BL 0.0 and hang a plumb line to obtain the measurement from BL 0.0 to the outside edge of the skid tubes as indicated in the maintenance manual.
3. Confirm forward crosstube is within deflection limits BHT-205A1-MM
4. Replace aft crosstubes that exceed the dimensional tolerances indicated.
5. Annotate helicopter / component records to indicate Part II of this bulletin has been accomplished.

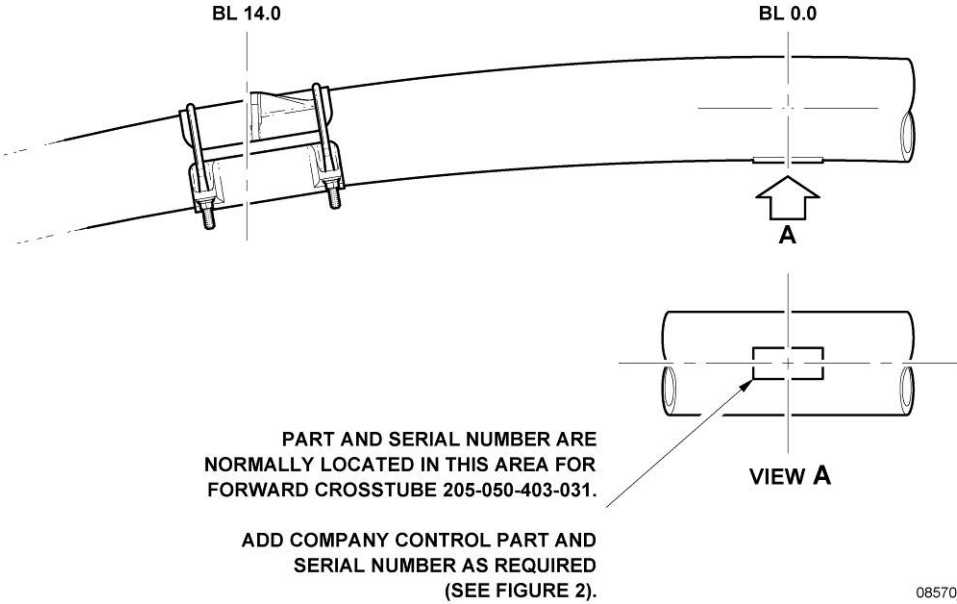

Figure 1

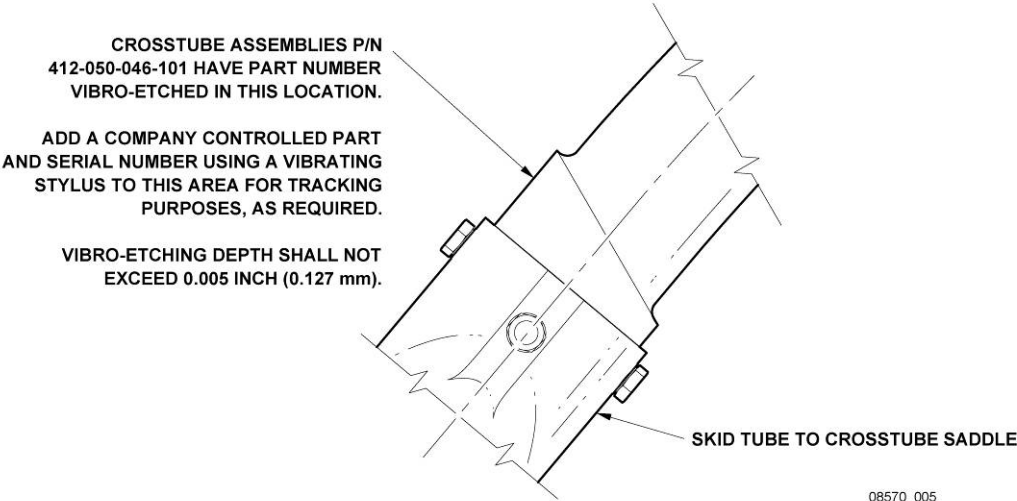
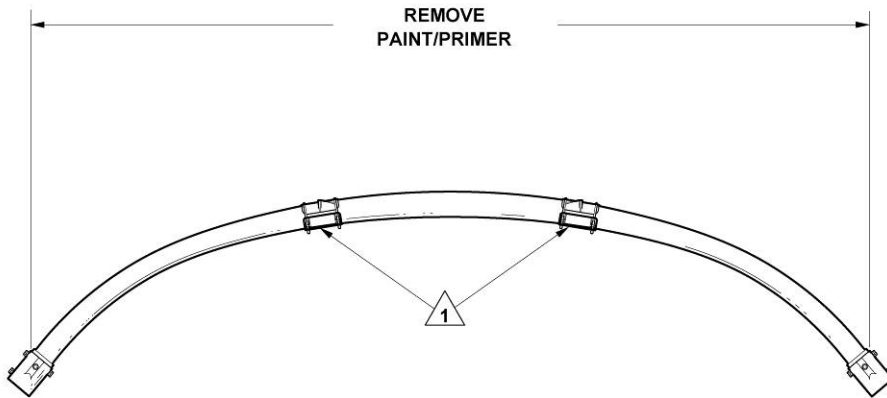

Figure 2



**NOTE**

1 Supports P/N 205-050-132-001 (upper) and 205-050-133-001 (lower) are removed prior to paint removal.

08570\_003

**Figure 3**

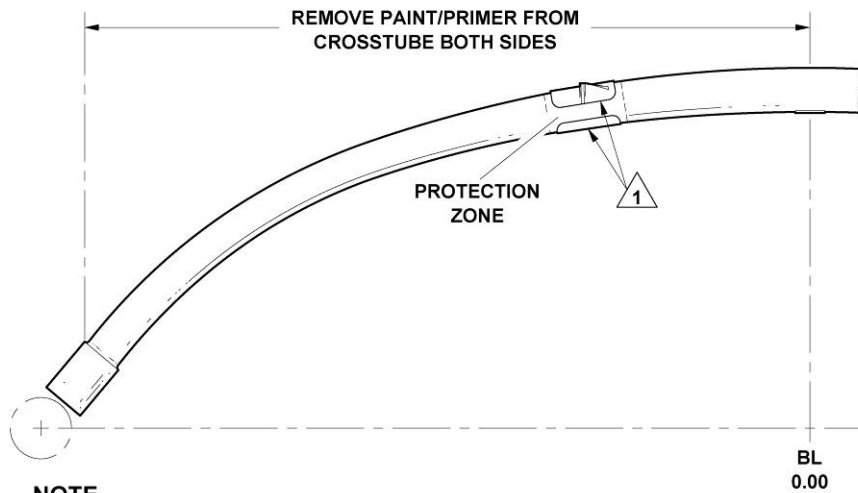

**NOTE**

1 Protect abrasion strip P/N 206-050-301-109 (lower) and support 412-050-038-101 (upper) (both sides) during paint removal process.

08570\_002

**Figure 4**