

ALERT SERVICE BULLETIN

REVISION NOTICE

Bell Helicopter **TEXTRON**

A Subsidiary of Textron Inc.

DATE Nov 10, 2005

TO: **All Owners/Operators of Bell 206L Helicopters**

SUBJECT: **REVISION "A" TO ALERT SERVICE BULLETIN 206L-05-136:
CLEVIS ASSEMBLY – HYDRAULIC SERVO ASSEMBLY, PART
NUMBER 41001520**

Revision "A" to this Alert Service Bulletin introduces the rewritten Hydraulic Research Textron Bulletin. Included in the rewritten bulletin are the following changes:

- The HR Textron Customer Service telephone number phone number, is added in Section 1, Step F.
- The compliance in Section 2, Step A, is changed.
- The inspection criteria are clarified in Section 2.
- HR Textron-Authorized Service Centers telephone and fax number are added in Table 1.
- A better graphic view of the proper installation is shown in Figure 1.

AN APPROPRIATE ENTRY SHOULD BE MADE IN THE AIRCRAFT LOGBOOK UPON ACCOMPLISHMENT
IF OWNERSHIP OF AIRCRAFT HAS CHANGED PLEASE FORWARD TO NEW OWNER

ALERT SERVICE BULLETIN
Bell Helicopter **TEXTRON**

A Subsidiary of Textron Inc.

NO. 206L-05-136

DATE Oct 17, 2005

PAGE 1 of 1

DATE Nov 10, 2005

REV A

MODEL AFFECTED: 206L; 206L-1; 206L-3; 206L-4

SUBJECT: CLEVIS ASSEMBLY – HYDRAULIC SERVO ASSEMBLY, PART NUMBER 41001520

HELICOPTERS AFFECTED: Bell 206L helicopters all serial numbers, 206L1 all serial numbers, 206L3 all serial numbers and 206L4 serial number 52001 through 52318, equipped with servo actuators 206-076-062-103 (HR TEXTRON P/N 41001520).

[Bell 206L-4 helicopters serial number 52319 and subsequent will have the intent of this bulletin accomplished prior to delivery.]

COMPLIANCE: See vendor Bulletin.

DESCRIPTION:

The purpose of this bulletin is to achieve complete distribution of the attached vendor bulletin to the current affected model distribution list on record by Bell Helicopter.

APPROVAL:

See vendor bulletin approval.

SERVICE BULLETIN

CLEVIS ASSEMBLY – HYDRAULIC SERVOACTUATOR, PART NUMBER 41001520

1. Planning Information

A. Effectivity

This service bulletin applies to the clevis assembly, P/N 41009477-101, used on the hydraulic servo assembly, HR part number 41001520 (BHT 206-076-062-103). The intent of this service bulletin has been incorporated into these servo actuators with serial numbers 1225 and subsequent.

B. Reason

HR has discovered the possibility that the shaft (280) (refer to Figure 1) could be loose. The looseness is as a result of lock washer tabs (285), improperly bent over the flat surface of the nut (290) or the flat surface of the clevis assembly (270A).

C. Description

This service bulletin defines mandatory inspection of nut, shaft and, clevis assembly for possible looseness as result of improper lock washer installation. This discrepancy is not traceable or identifiable except by inspection. This inspection is applicable to servos identified in paragraph 1.A.of this bulletin.

D. Approval

HR Textron Engineering.

E. Manpower

Approximately 2.0 man-hour, are required to remove and reinstall each hydraulic servo actuator and approximately 0.5 man-hour is sufficient to conduct visual inspection.

F. Material Price and Availability

Prior to returning any servo to service center, contact HR Textron Customer Service and Field Service Manager at: 25200 West Rye Canyon Road, Santa Clarita, CA 91355-1265; 661-702-5509, or 661-702-5358 (tel. numbers) mhowell@hrtextron.Textron.com (email); or 661-702-5970 (fax). Provide HR Textron with the part number, serial number, time since new for new servo and in addition time since overhauled or repaired and the facility if the servo was recently overhauled or repaired. This applies to servos that are found with loose nut, shaft or clevis assembly or improperly installed lock washer only. Warranty claims will be handled on a case-by-case basis.

EXPORT CONTROL WARNING

This document contains technical data whose export, transfer, disclosure, and further publication are restricted by the applicable export laws and regulations of the United States of America, including the Export Administration Act of 1979, as amended, and the Export Administration Regulations. Violations of these laws and regulations are subject to severe civil, criminal, and administrative penalties.

November 9, 2005
Revision 2

41001520-67-01

Page 1 of 4

SERVICE BULLETIN

G. Tooling Price and Availability

New tools are not required.

H. Weight and Balance

Not affected.

I. Electrical Load Data

Not affected.

J. References

67-31-04 Component Maintenance Manual with Illustrated Parts List (for) Hydraulic Servo Actuator Assembly part number 41001520 (BHT 206-076-062-103).

K. Other Publications Affected

The intent of this service bulletin will be incorporated into the next revision of 67-31-04.

2. Accomplishment Instructions

A. Within the next 10 flight hours or before December 15, 2005, whichever comes first, accomplish this one-time mandatory inspection.

B. Retract the boot (305A) and perform the following inspections:

1. Applying hand pressure only, and check if the nut, the shaft or the clevis assembly is turning independently from one another.
2. If the shaft will turn independently to the nut or the clevis assembly, prior to the next flight, the actuator shall be removed from service and forwarded to HR Textron or one of the HR Textron Service Centers listed in Table 1. Check step 1.F. for condition.
3. If the shaft is not turning independently from the nut or the clevis assembly proceed with step 2.B.4.
4. Check if at least one tab of the lock washer is bent flush against one of the nut flat surface and if at least one tab of the lock washer is bent flush against one of the two flat surfaces of the clevis assembly. Lock washer tab must also be in line with the flat surface of the nut and clevis assembly. If the lock washer tabs are not bent flush against the nut and clevis assembly or are not in line with the flats, proceed with the following steps.
5. If the lock washer tabs are not bent flush against the nut or clevis assembly flat surface, use needle-nosed pliers and make sure the lock washer tab is flush against nut or the flat surface of the clevis assembly.

Use or disclosure of data on this page are subject to the restriction on Page 1.

November 9, 2005
Revision 2

41001520-67-01

Page 2 of 4

SERVICE BULLETIN

6. If the lock washer tab is on the edge or not aligned with a flat surface (nut or clevis assembly). Within the next 300 hours, but not later than April 30, 2006, the actuator shall be removed from service and forwarded to HR Textron or one of the HR Textron Service Centers listed in Table 1. Check step 1.F. for condition.
- C. If the servo meets all the requirements of the inspection or if the operator can accomplish the corrective action, the operator may perform the necessary corrective repairs. Remove modification plate from servo and metal-impression stamp or vibro-etch an abbreviated service bulletin number (67-01) on modification plate to identify compliance with this service bulletin. Modification plates are available; HR Textron will provide replacement modification plates if necessary. Corrective action accomplished by HR Textron or approved repair station will have the same identification added to modification plate.

Table 1. HR Textron-Authorized Service Centers

AEM Ltd 8 Wilton Road Haine Industrial Estate Ramsgate, Kent CT12 5HE (England) Tel; 001-(44)-1-843-591-381 Fax; 011-(44)-1-843-592-641	Helicopter Support Inc. 116 Quarry Road Trumbull, CT 06611 (USA) Tel; (203) 416-4300 Fax; (203) 416-4282
Stansted Airport Stansted, Essex CM24 1RB (England) Tel; 011-(44)-1-279-680-030 Fax; 011-(44)-1-279-680-040	JAMCO Corp 6-11-25 Osawa Mitaka Tokyo 181 (Japan) Tel; 011-(81) 422-31-6111 Fax; 011 (81) 422-32-6998
HASE Helicopter Accessory Service Inc. East 10102 Aileron Avenue Pensacola, FL 32506 (USA) Tel; (850) 456-8339 Fax; (850) 456-5117	Motorflug GmbH Baden-Airpark Gebäude C-312 D-77836 Rheinmunster, Germany Tel; 011 (49) 7229-301-430 Fax; 011 (49) 7229-301-433
HAS West Helicopter Accessory Service Inc. West 10985 Penrose Street Sun Valley, CA 91352 (USA) Tel; (818) 767-2214 Fax; (818) 767-2699	Ostermans Aero AB Box 116 SE-190 46 Stockholm-Arlanda Sweden Tel; 011-(46)-8-593-787-00 Fax; 011-(46)-8-593-787-90
HELITRADES 18 Terry Fox Drive Vanleek Hill, Ontario, Canada K0B 1R0 Tel; (613) 678-3027 Fax; (613) 678-2776	HELITRADES Site 5, Box 7, RR 2 Airdrie Airport Airdrie, Canada K0B 1R0 Tel; (403) 912-4658 Fax; (403) 948-6475

Use or disclosure of data on this page are subject to the restriction on Page 1.

November 9, 2005
Revision 2

41001520-67-01

Page 3 of 4

HR TEXTRON

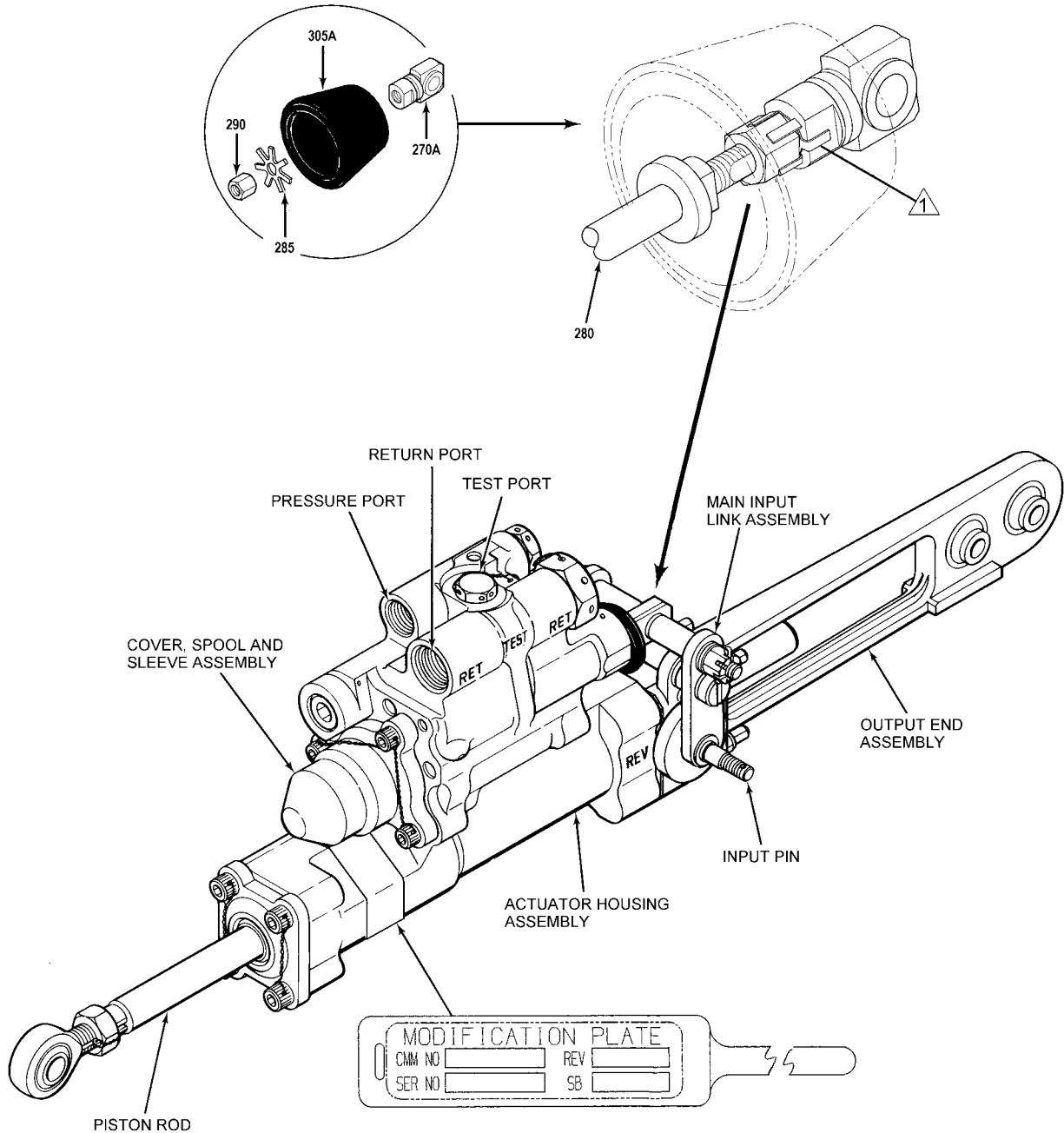

NOTE:

- 1 ACCEPTABLE CONDITION
 A MINIMUM OF ONE TAB SHALL BE IN LINE AND BENT FLUSH WITH THE NUT FLAT SURFACE AND A MINIMUM OF ONE TAB SHALL BE IN LINE AND BENT FLUSH WITH THE CLEVIS ASSEMBLY FLAT SURFACE

Clevis Assembly
 Figure 1

Use or disclosure of data on this page are subject to the restriction on Page 1.

November 9, 2005
 Revision 2

41001520-67-01
 Page 4 of 4