



ALERT SERVICE BULLETIN

212-12-144  
18 January 2012

**MODEL AFFECTED:** 212

**SUBJECT:** MAIN ROTOR GRIP 204-011-121-009/ -121 ONE-TIME INSPECTION AND REWORK OF

**HELICOPTERS AFFECTED:** Serial number 30501 through 30999, 31101 through 31311, 32101 through 32142 and 35001 through 35103.

**COMPLIANCE:** Within the next 300 flight hours or 6 months after release of this bulletin

**DESCRIPTION:**

Main rotor grip serial numbers listed in Table 1 of the ACCOMPLISHMENT INSTRUCTIONS may have been incorrectly marked during conversion to grease lubrication. Grips that are incorrectly marked have the letter "G" impression stamped on the grip beside the data plate. Part I mandates a one-time inspection of grips listed in Table 1 for marking and Part II provides rework instructions if required. Applicability of this bulletin to any spare part shall be determined prior to its installation on an affected aircraft.

**APPROVAL:**

The engineering design aspects of this bulletin are FAA/ODA approved.

**CONTACT INFO:**

For any questions regarding this bulletin, please contact:

Bell Helicopter Product Support Engineering - Medium Helicopters  
Tel: 817-280-3548 / [mts-medium@bellhelicopter.textron.com](mailto:mts-medium@bellhelicopter.textron.com)

**MANPOWER:**

Time required to accomplish Part I of this bulletin is negligible. Approximately 5.0 man-hours are required to complete Part II of this bulletin. Man-hours are based on hands-on time, and may vary with personnel and facilities available.

**WARRANTY:**

There is no warranty credit applicable for parts or labor associated with this bulletin.

**MATERIAL:****Required Material:**

The following material is required for the accomplishment of this bulletin and may be obtained through your Bell Helicopter Textron Supply Center.

<u>Part Number</u>	<u>Nomenclature</u>	<u>Quantity</u>
100-140-2	Data Plate	2

Note: Data plate will be required only if a rework (Part II) is necessary.

**Consumable Material:**

The following material is required to accomplish this bulletin, but may not require ordering, depending on the operator's consumable material stock levels. This material may be obtained through your Bell Helicopter Textron Supply Center.

<u>Part Number</u>	<u>Nomenclature</u>	<u>Quantity</u>	<u>Reference</u>
ABRASIVE 240 GRIT	Abrasive Cloth or paper	A/R	C-423
Chemical Film Material for Aluminum	Alodine 1201	A/R	C-100
MIL-PRF-12277, TYPE I or II, CLASS C2	Primer, Epoxy Polyamide	A/R	C-204
MIL-L-PRF- 85285D (16440)	Coating, Polyurethane (Gray)	A/R	C-245
TT-N-95, Type II	Aliphatic Naphtha	A/R	C-305
ASTM D740	METHYL Ethyl Keytone	1 GAL	C-309
299-947-100	Adhesive, Epoxy Base	1 PT	C-317
CCC-C-440, CLASS 1	Cheesecloth, Cotton	A/R	C-486

**SPECIAL TOOLS:**

Surface Finish Scale  
Pin Mic Gage

**WEIGHT AND BALANCE:**

Not affected

**ELECTRICAL LOAD DATA:**

Not affected

**REFERENCES:**

BHT-ALL-SPM Standard Practices Manual

**PUBLICATIONS AFFECTED:**

None affected

**ACCOMPLISHMENT INSTRUCTIONS:**

**PART I. Inspection for “G” letter marking.**

1. Access Main Rotor Hub and inspect grip data plate for proper identification. Grip data plate should have “G” vibro-etched on data plate after part number, not impression stamped on grip. Reference Figure 1.
2. If letter “G” is not visible on either the data plate or the grip. It is possible that the impression stamp “G” has been filled with paint. Remove paint in accordance with BHT-ALL-SPM, Chapter 4 and inspect the area 1.5” adjacent to the data plate.
3. If data plate is marked correctly, annotate Historical Records to indicate findings and that Part I of this bulletin has been accomplished. If grip was marked incorrectly, comply with Part II.

## **PART II. Main rotor grip rework.**

1. Using Pin Mic gauge, measure the depth of the stamped "G". If depth is less than 0.030 inch grip is repairable. Document the depth of the stamping. If the depth exceeds 0.030 inch, contact Product Support Engineering.
2. Apply heat (do not exceed 200°F) to weaken the adhesive and remove data plate with adhesive residue from the grip.
3. Perform a Dye Penetrant Inspection (per product manufacturer's instructions) of area, no crack allowed.
4. Using C-423, sand the grip in a span wise direction to remove the documented depth of the stamping plus 0.020 inch. Maximum repair depth not to exceed 0.050 inch. Sand the grip to a surface finish of 63 RMS. A minimum blend radius of 1 inch should be observed.

-NOTE-

Re-shotpeening repaired area is not required.

5. To ensure no induced damage, perform another Dye Penetrant Inspection of area, no crack allowed.
6. Using C-100, apply Alodine treatment to repaired area.
7. Using C-204, prime repaired area.
8. Using paint C-245, paint repaired area.
9. Vibro-etch the part number with the letter "G" after the last three digits and serial number on the replacement data plate (100-140-2), prior to installation on grip.
10. Install new data plate per BHT-ALL-SPM, Chapter 8. Install new data plate in the same location on grip where old data plate was located. Reference Figure 1.
11. Annotate helicopter and grip Historical Records to indicate that this Alert Service Bulletin has been accomplished.

**Table 1. Grip serial numbers affected**

A-05181	A-05809	A-05920	A-05976	A-06032	A-06139	A-06233	A-06497	A-06382	A-06638	A-06705	A-06758	A-06813	A-06868	A-07000	A-07114	A-07319
A-05182	A-05820	A-05922	A-05978	A-06034	A-06153	A-06238	A-06498	A-06383	A-06640	A-06706	A-06759	A-06814	A-06871	A-07001	A-07115	A-07320
A-05183	A-05830	A-05923	A-05979	A-06035	A-06155	A-06242	A-06514	A-06390	A-06641	A-06709	A-06760	A-06815	A-06872	A-07003	A-07117	A-07333
A-05184	A-05831	A-05925	A-05980	A-06040	A-06156	A-06244	A-06515	A-06391	A-06642	A-06711	A-06761	A-06816	A-06873	A-07007	A-07166	A-07335
A-05298	A-05834	A-05930	A-05981	A-06041	A-06159	A-06246	A-06516	A-06412	A-06643	A-06712	A-06762	A-06817	A-06875	A-07008	A-07167	
A-05299	A-05837	A-05938	A-05982	A-06045	A-06163	A-06248	A-06517	A-06414	A-06644	A-06713	A-06763	A-06823	A-06880	A-07010	A-07170	
A-05376	A-05839	A-05940	A-05983	A-06046	A-06164	A-06253	A-06518	A-06416	A-06648	A-06714	A-06764	A-06824	A-06882	A-07015	A-07171	
A-05377	A-05847	A-05941	A-05984	A-06048	A-06165	A-06254	A-06519	A-06420	A-06651	A-06715	A-06765	A-06831	A-06885	A-07018	A-07172	
A-05387	A-05852	A-05945	A-05985	A-06049	A-06166	A-06256	A-06520	A-06426	A-06657	A-06716	A-06771	A-06833	A-06886	A-07023	A-07182	
A-05390	A-05859	A-05946	A-05986	A-06050	A-06181	A-06257	A-06521	A-06429	A-06661	A-06717	A-06772	A-06834	A-06888	A-07025	A-07183	
A-05637	A-05862	A-05947	A-05987	A-06052	A-06182	A-06259	A-06528	A-06440	A-06662	A-06718	A-06773	A-06835	A-06922	A-07038	A-07184	
A-05639	A-05863	A-05948	A-05991	A-06053	A-06185	A-06267	A-06529	A-06469	A-06663	A-06719	A-06774	A-06836	A-06925	A-07039	A-07185	
A-05641	A-05865	A-05949	A-05992	A-06055	A-06187	A-06268	A-06530	A-06470	A-06664	A-06720	A-06775	A-06837	A-06927	A-07040	A-07186	
A-05642	A-05866	A-05950	A-06001	A-06056	A-06189	A-06269	A-06531	A-06474	A-06666	A-06722	A-06776	A-06838	A-06929	A-07041	A-07188	
A-05676	A-05871	A-05951	A-06002	A-06057	A-06193	A-06273	A-06532	A-06475	A-06667	A-06725	A-06777	A-06841	A-06932	A-07042	A-07189	
A-05711	A-05873	A-05952	A-06003	A-06058	A-06194	A-06274	A-06533	A-06478	A-06668	A-06726	A-06778	A-06843	A-06933	A-07043	A-07190	
A-05712	A-05875	A-05953	A-06004	A-06059	A-06195	A-06277	A-06534	A-06479	A-06672	A-06729	A-06779	A-06844	A-06934	A-07044	A-07191	
A-05717	A-05881	A-05954	A-06005	A-06068	A-06199	A-06278	A-06535	A-06480	A-06674	A-06730	A-06786	A-06845	A-06935	A-07045	A-07193	
A-05721	A-05882	A-05955	A-06006	A-06071	A-06200	A-06279	A-06536	A-06481	A-06675	A-06731	A-06795	A-06847	A-06936	A-07046	A-07195	
A-05722	A-05883	A-05956	A-06011	A-06075	A-06203	A-06441	A-06819	A-06484	A-06677	A-06732	A-06797	A-06848	A-06937	A-07047	A-07198	
A-05723	A-05887	A-05957	A-06018	A-06077	A-06204	A-06442	A-06665	A-06549	A-06678	A-06734	A-06798	A-06850	A-06938	A-07048	A-07199	
A-05764	A-05888	A-05958	A-06020	A-06080	A-06205	A-06444	A-06295	A-06550	A-06679	A-06736	A-06801	A-06851	A-06939	A-07050	A-07232	
A-05767	A-05889	A-05959	A-06021	A-06083	A-06209	A-06445	A-06345	A-06614	A-06680	A-06737	A-06802	A-06852	A-06941	A-07052	A-07234	
A-05768	A-05893	A-05960	A-06022	A-06084	A-06212	A-06446	A-06348	A-06620	A-06685	A-06738	A-06803	A-06853	A-06942	A-07054	A-07235	
A-05769	A-05894	A-05961	A-06023	A-06089	A-06213	A-06447	A-06368	A-06621	A-06686	A-06739	A-06804	A-06856	A-06943	A-07087	A-07237	
A-05771	A-05895	A-05962	A-06024	A-06090	A-06215	A-06449	A-06370	A-06626	A-06688	A-06740	A-06805	A-06857	A-06986	A-07103	A-07238	
A-05772	A-05908	A-05963	A-06025	A-06091	A-06217	A-06450	A-06371	A-06627	A-06689	A-06741	A-06806	A-06859	A-06992	A-07318	A-07239	
A-05775	A-05911	A-05964	A-06026	A-06119	A-06218	A-06452	A-06372	A-06628	A-06690	A-06742	A-06807	A-06861	A-06993	A-07319	A-07311	
A-05779	A-05913	A-05965	A-06027	A-06120	A-06220	A-06459	A-06373	A-06630	A-06691	A-06743	A-06808	A-06862	A-06994	A-07320	A-07312	
A-05782	A-05914	A-05967	A-06028	A-06130	A-06222	A-06491	A-06376	A-06631	A-06692	A-06744	A-06809	A-06864	A-06995	A-07333	A-07314	
A-05798	A-05915	A-05971	A-06029	A-06131	A-06226	A-06492	A-06377	A-06634	A-06693	A-06745	A-06810	A-06865	A-06997	A-07335	A-07316	
A-05805	A-05916	A-05974	A-06030	A-06132	A-06227	A-06493	A-06378	A-06635	A-06698	A-06747	A-06811	A-06866	A-06998	A-07111	A-07317	
A-05807	A-05918	A-05975	A-06031	A-06133	A-06231	A-06494	A-06380	A-06636	A-06700	A-06748	A-06812	A-06867	A-06999	A-07112	A-07318	

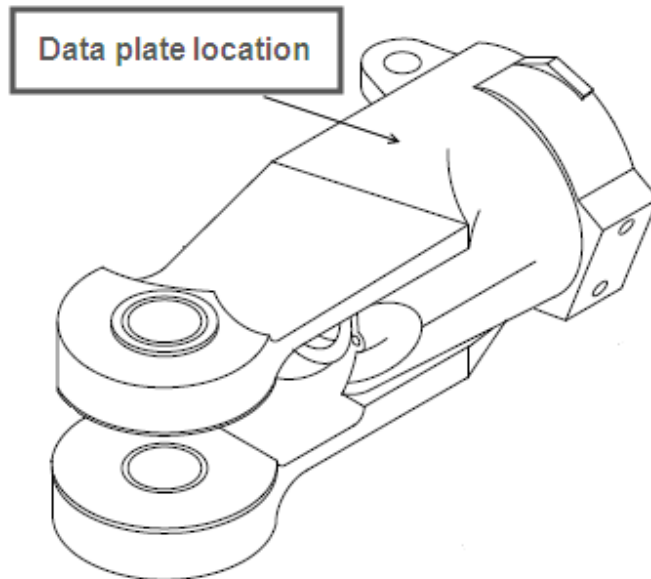

**Figure 1. Main rotor grip inspection and rework.**