

ALERT SERVICE BULLETIN
Bell Helicopter **TEXTRON**

A Subsidiary of Textron Inc.

NO. 222U-07-75

DATE JAN 09, 2007

PAGE 1 of 8

DATE

REV

MODEL AFFECTED: 222U

SUBJECT: TAIL ROTOR PITCH CHANGE MECHANISM,
REVISED RIGGING PROCEDURES

HELICOPTERS AFFECTED: All Model 222U helicopters

COMPLIANCE: At the next 150 hour or Annual inspection but no
later than Dec. 31, 2007

DESCRIPTION:

It has come to the attention of Bell Helicopter Textron that due to parts tolerance buildup, the existing rigging procedures for the tail rotor pitch change mechanism can create a condition in which the position of the tail rotor counterweight bellcranks may not be at their optimized position to assist the flight crew with the tail rotor pedal forces in an emergency type operation with # 1 hydraulic system inoperative.

This bulletin introduces a one time verification of the tail rotor pitch change mechanism rigging and introduces new rigging procedures for the tail rotor pitch change mechanism.

APPROVAL:

The engineering design aspects of this bulletin are Transport Canada Civil Aviation (TCCA) approved.

MANPOWER:

Approximately 2.0 man-hours are required to complete this bulletin. Man-hours are based on hands-on time, and may vary with personnel and facilities available. Man-hour estimates do not include the man-hours required to replace the tail rotor yoke if it is determined that it requires replacement.

WARRANTY:

Owner / Operators who have performed the inspection of the tail rotor hub outlined in this bulletin and could not achieve optimized positioning of the tail rotor counterweight bellcranks should order a replacement yoke part number 222-012-702-117. They will receive a pro-rated warranty credit based on a 5000 hour life limited part. If the lockplates part number 222-012-733-001 and 222-012-738-001 are required, 100% warranty credit will be allowed for the lockplates listed in the required material section of this ASB.

To Receive This Credit:

Order a replacement tail rotor yoke part number 222-012-702-117 from an approved Bell Helicopter Supply Source, submit a warranty claim, and a pro-rated warranty will be issued based on a 5000 hour life limited part. The yoke removed from service will have to be returned to Bell. The returned yoke will be inspected at Bell. If the yoke can not be reworked, the original warranty credit will be rescinded and the discrepant yoke will be returned to the customer at their expense in "as is condition."

To be eligible for the credit mentioned above the ASB must be completed no later than 31 December 2007.

There is no warranty credit for labor associated with this ASB.

MATERIAL:

Required Material:

The following material is required for the accomplishment of this bulletin and may be obtained through your Bell Helicopter Textron Supply Center.

<u>Part Number</u>	<u>Nomenclature</u>	<u>Quantity</u>
222-012-733-001	Lockplate	As required (Note 1)
222-012-738-001	Lockplate	As required (Note 1)
222-012-702-117	Tail rotor yoke	As required (Note 1,2)

-NOTE-

1. Quantities to be determined by completing accomplishment instructions described below
2. Used with T/R blades P/N 222-016-001-139 only

Consumable Material:

None required

SPECIAL TOOLS:

None required

WEIGHT AND BALANCE:

Not affected

ELECTRICAL LOAD DATA:

Not affected

REFERENCES:

BHT-222U-MM-7 Maintenance Manual
BHT-222U-MM-7 Illustrated Parts Breakdown
T.B. 222U-06-99

PUBLICATIONS AFFECTED:

BHT-222U-MM-7, chapter 64-00-00
BHT-222U-MM-7 Illustrated Parts Breakdown

ACCOMPLISHMENT INSTRUCTIONS:

-NOTE-

It is not required to verify the directional controls rigging before complying with this bulletin. However if you suspect any discrepancy with the existing directional controls rigging, a verification of the directional controls rigging must be carried out before complying with this bulletin.

Hydraulic power is NOT required to verify the rigging of the tail rotor pitch change mechanism.

Any adjustment that may be carried out to the support (6) by turning nut (4) and nut (8) will not change or affect the existing tail rotor controls/blade angle rigging settings.

1. Move the tail rotor pedals as required and set the pitch change housing to obtain a 4.63 to 4.65 inches (117.6 to 118.1 mm) dimension as shown in Figure 1. Maintain this position.

-NOTE-

The lockplates (5 and 7) may remain in service if adjustment to nut (4) and nut (8) is required. However, re-bending/re-using any previously bent edge of the lockplates is not permitted.

2. Verify that the centerline of counterweight bellcranks, (12, Figure 2) are parallel with the centerline of the tail rotor gearbox output shaft. If the counterweight bellcranks (12) are parallel with the centerline of the tail rotor gearbox output shaft, proceed to step 3. If the counterweight bellcranks (12) are not parallel with the centerline of the tail rotor gearbox output shaft, disconnect boot (9), pitch links (11) and counterweight links (10) as required. Straighten the bent edges of the lockplates (5 and 7) and adjust nut (4) and nut (8) to reposition support (6) until the counterweight bellcranks are parallel with the centerline of the tail rotor gearbox output shaft. Hold the nut (8) in position and torque the nut (4) to 50 to 55 foot-pounds (68 to 75 Nm). Do not bend the edge of the lockplates (5 and 7) into the slots of nut (4 and 8) at this time.

-NOTE-

Tail rotor yoke P/N 222-012-702-117 incorporates a larger cut-out area that will provide additional clearance with nut (4) while maintaining the correct position of the counterweight bellcranks (12).

Tail rotor yoke P/N 222-012-702-117 can only be used with tail rotor blades P/N 222-016-001-139 which incorporate the improved feathering bearings per T.B. 222U-06-99.

3. Move the tail rotor assembly through the full flap range (verify at both full flap positions). Verify if the tail rotor yoke touches the flapping stop (3) before it touches nut (4). If a gap exists between the flapping stop (3) and the tail rotor yoke, replace the existing tail rotor yoke with yoke P/N 222-012-702-117. Notify BHT Product Support Engineering if yoke replacement is required.

CAUTION

Do not use standard width feeler gauges to measure the referenced gap as these feeler gauges are too wide and they do not permit measuring gaps between mating parts that

have a curvature. Wire type feeler gauges are best suited for this application.

Due to possible variations in parts tolerances, the measured gap reference below shall be the smallest gap that is measured at any location between the tail rotor yoke and nut (4) when the tail rotor assembly is moved through the full flap range (verify at both full flap positions).

-NOTE-

There is no maximum limit on the gap that may exist between the tail rotor yoke and nut (4) when the pitch change housing is positioned as shown in figure 1 and the counterweight bellcranks (12) are parallel to the tail rotor gearbox output shaft.

4. If there is no gap between the flapping stop (3) and the tail rotor yoke, verify if a 0.020 inch (0.50 mm) wire type feeler gauge can be inserted between the tail rotor yoke and nut (4). If the smallest gap between the tail rotor yoke and nut (4) is 0.020 inch (0.50 mm) or more, bend the edge of the lockplates (5 and 7) into the slots of nut (4 and 8). Connect boot (9), pitch links (11) and counterweight links (10) as required and proceed to step 6.

-NOTE-

Adjusting nut (4) and nut (8) to obtain a 0.020 to 0.030 inch (0.50 to 0.76 mm) gap between the tail rotor yoke and nut (4) will result in a minor misalignment of the counterweight bellcranks (12) in relation to the tail rotor gearbox output shaft. A maximum misalignment of 1.6 degrees of the counterweight bellcranks (12) in relation to the tail rotor gearbox output shaft is acceptable when the pitch change housing is positioned as shown in figure 1.

CAUTION

Do not adjust nut (4) and nut (8) to obtain a gap of more than 0.030 inch (0.76 mm) between the tail rotor yoke and nut (4). This will result in misalignment of the counterweight bellcranks (12) beyond the permissible maximum limit of 1.6 degrees (in relation to the tail rotor gearbox output shaft) when the pitch change housing is positioned as shown in figure 1. This is NOT acceptable.

5. If the gap between the tail rotor yoke and nut (4) measures between 0.000 and 0.019 inch (0 to 0.48 mm), adjust nut (4) and nut (8) until a gap of 0.020 to 0.030 inch (0.50 to 0.76 mm) maximum exists between the tail rotor yoke and nut (4). Hold the nut (8) in position and torque the nut (4) to 50 to 55 foot-pounds (68 to 75 Nm). Bend the edge of the lockplates (5 and 7) into the slots of the nut (4) and nut (8). Connect boot (9), pitch links (11) and counterweight links (10) as required.
6. Examine and adjust the tail rotor pedal forces if any adjustments were carried out to support (6). Refer to BHT-222U-MM-7, chapter 64-00-00.
7. Annotate helicopter records to reflect compliance with this bulletin.
8. Insert the BHT-222U-MM-7 Revision 7, dated 15 Dec. 2006 into the BHT-222U-MM-7 manual.

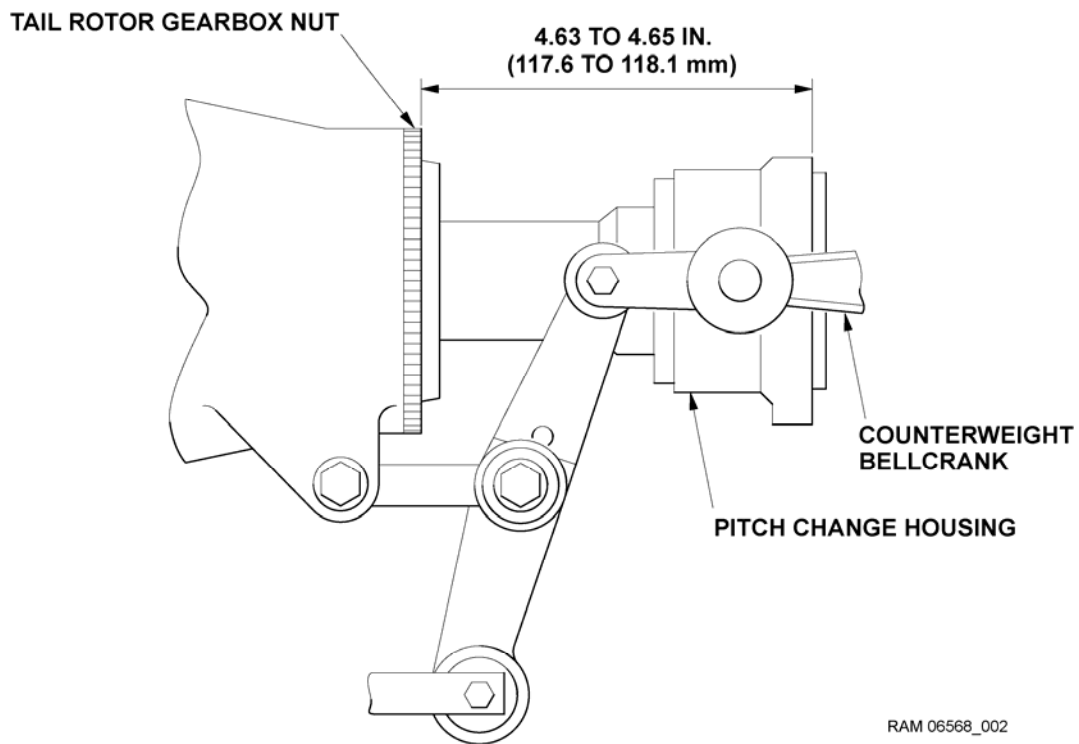
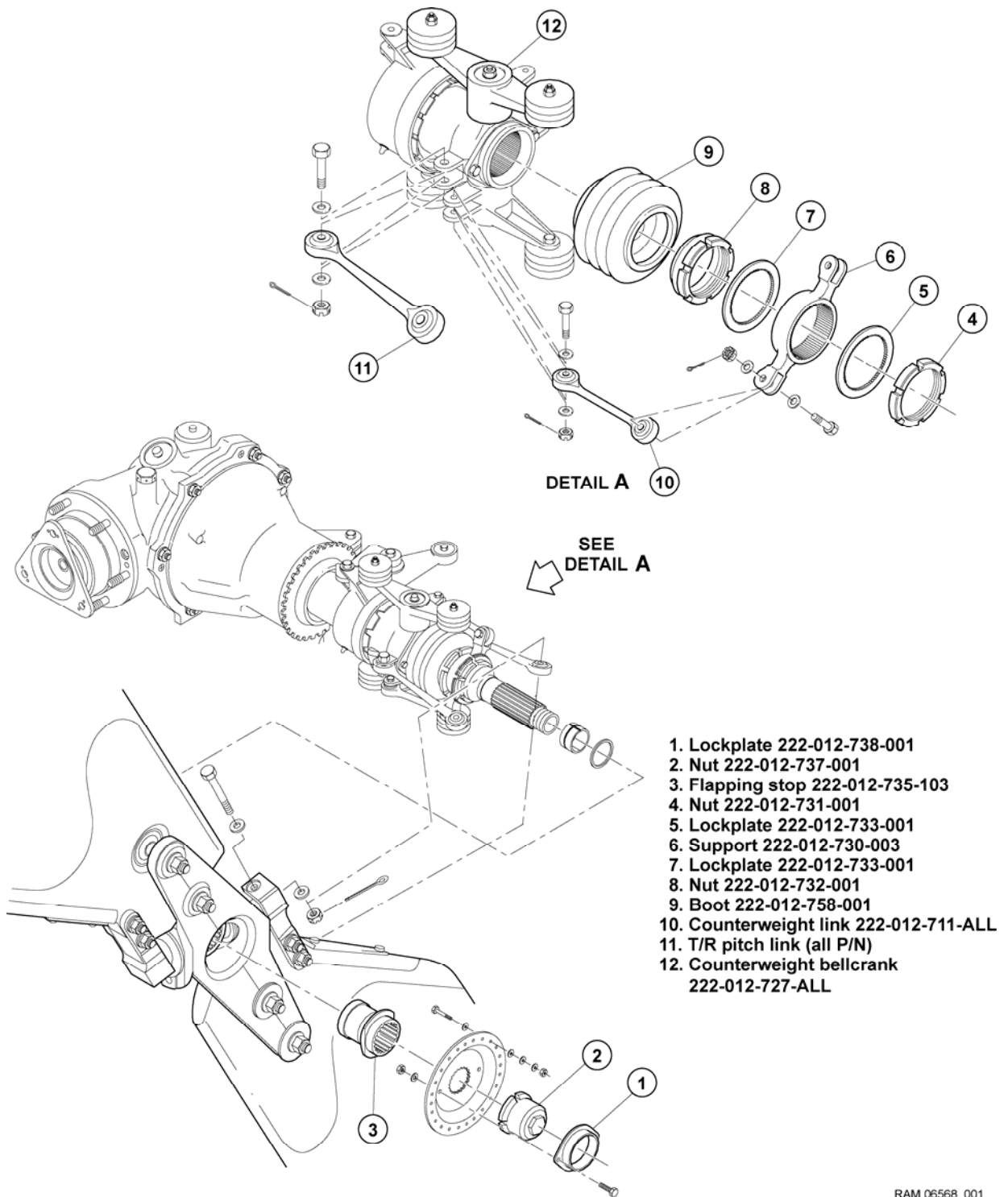

Figure 1. Tail Rotor Pitch Change Mechanism (Position)



RAM 06568_001

Figure 2. Tail Rotor Pitch Change Mechanism