

**ALERT SERVICE BULLETIN**

407-00-36

**Bell Helicopter** **TEXTRON**

A Subsidiary of Textron Inc.

NO.

06-16-00

DATE

PAGE

1 of 9

DATE

REV

**MODELS AFFECTED:** 407

**SUBJECT:** 170 AMP MAXIMUM CONTINUOUS ELECTRICAL LOAD LIMIT FOR OPERATIONS ABOVE 10,000' DENSITY ALTITUDE, INTRODUCTION OF.

**HELICOPTERS AFFECTED:** Part 1 : S/N 53000 through 53424

[Helicopters S/N 53425 through 53440 will have the intent of Part 1 of this bulletin completed before delivery]

Part 2 : S/N 53000 through 53440

[Helicopters S/N 53441 and subsequent will have the intent of Part 2 of this bulletin completed before delivery]

**COMPLIANCE:** Part 1:

Within the next 100 hours of flight time after you receive this bulletin, but no later than 31 October 2000.

Part 2:

No later than February 1, 2003.

**DESCRIPTION:**

This bulletin introduces a 170 ampere marking on the Fuel Pressure / Ammeter indicator. The 170 ampere marking is required to notify pilots that this is the maximum continuous electrical load limitation for flight operations above 10,000' density altitude. The 170 ampere load limit ensures adequate generator cooling during flight operations above 10,000' density altitude.

The 170 ampere limitation is addressed in BHT-407-FM-1 Revision 8 which is enclosed with this Alert Service Bulletin.

7851 55192 REV 1199

The instructions called out in Part 1 or Part 2 of this bulletin must be completed prior to insertion of BHT-407-FM-1 Revision 8 into the Flight Manual.

It should also be noted that Revision 8 of the Flight Manual introduces a new Altitude limitation which allows Takeoff, Landing and Hovering manoeuvres up to 17,000' density altitude. The 17,000' density altitude information is also provided in Particle Separator Flight Manual Supplement BHT-407-FMS-3 Rev. 3 and Snow Deflector Flight Manual Supplement BHT-407-FMS-4 Rev. 3. Introduction of this improved operational capability is the primary reason for the 170 ampere limitation above 10,000' density altitude.

Although these Flight Manual changes introduce Takeoff, Landing, and Hovering manoeuvres up to 17,000' density altitude, the following Flight Manual Temporary Revisions titled – HOVER PERFORMANCE CORRECTION FOR TEMPORARY TAIL ROTOR PEDAL STOP, dated 10 March 1999, or later approved revision, remain in affect for helicopters prior to s/n 53400 until ASB 407-99-33 is complied with:

BHT-407-FM-1  
BHT-407-FMS-3, PARTICLE SEPARATOR  
BHT-407-FMS-4, SNOW DEFLECTOR

Part 1 of this bulletin gives instructions to modify existing Fuel Pressure / Ammeter Indicators P/N 407-375-007-101 and –103. The indicators require modification to include the new instrument marking at 170 amps. This is accomplished by addition of an externally mounted decal on the face of the indicator. Following completion of the modification, the indicators are reidentified as P/N 407-075-024-101 and –103.

Part 2 of this bulletin requires replacement of modified Fuel Pressure / Ammeter indicators P/N 407-075-024-101 and –103 by February 1, 2003. This requirement is to ensure all operators install Fuel Pressure / Ammeter indicator P/N 407-375-007-105, which has the 170 ampere marking located internally. Please refer to the Warranty Statement of this bulletin for information on how to obtain the new indicator.

Production helicopters S/N 53441 and subsequent will be delivered with new Fuel Pressure / Ammeter Indicator P/N 407-375-007-105. This indicator will be the direct part replacement for all previous Fuel Pressure / Ammeter indicators.

**APPROVAL:**

The engineering design aspects of this bulletin are Transport Canada approved.

**MANPOWER:**

Approximately 1.0 man-hour is required to complete this bulletin. Man-hours are based on hands-on time, and may vary with personnel and facilities available.

**WARRANTY:**

Owners/operators of 407 helicopters who comply with the instructions outlined in this bulletin are eligible for a 100 % credit toward the purchase of the part(s) contained in the "Required Material" section of this bulletin.

To receive this credit:

- The part(s) must be purchased from an approved BHTI supply source.
- Send a completed malfunction Report (MR) to BHT warranty Administration within 30 days of completion of this bulletin.

- NOTE -

Customers who fail to comply with the instruction in this bulletin prior to February 1, 2003 are not eligible for the special warranty credit provisions listed above.

**MATERIAL:**

**Required Material:**

The following material is required for the accomplishment of this bulletin and can be obtained through your Bell Helicopter Supply Center.

**Part 1: S/N 53000 through 53424**

<u>Part Number</u>	<u>Nomenclature</u>	<u>Quantity</u>
407-075-024-115	DECAL	1
100-088-1	PLATE, IDENTIFICATION	1

**Part 2 : S/N 53000 through 53440**

<u>Part Number</u>	<u>Nomenclature</u>	<u>Quantity</u>
407-375-007-105	INDICATOR	1

**Consumable Material:**

The following material is required to accomplish this bulletin, but may not require ordering, depending on the operators consumable material stock levels. This material may be obtained through your Bell Helicopter Textron Supply Center.

<u>Part Number</u>	<u>Nomenclature</u>	<u>Quantity</u>	<u>Reference</u>
TT-N-95TYII, 1 Gal	Aliphatic Naphtha	As required	C-305

- NOTE -

The "C" reference number is a cross reference found in the Standard Practices Manual.

**SPECIAL TOOLS:**

None required.

**WEIGHT AND BALANCE:**

Not affected.

**ELECTRICAL LOAD DATA:**

Not affected.

**REFERENCES:**

BHT-407-FM-1, Rev.8, 17 April 2000

Section 1, Limitations

BHT-407-FMS-3, Rev. 3, 17 April 2000

BHT-407-FMS-4, Rev. 3, 17 April 2000

BHT-407-MM-10, Rev. 7, 01 May 1998

Chapter 95, Instruments

**PUBLICATIONS AFFECTED:**

BHT-407-FM-1, Rev. 7, 04 September 1998

Section 1, Limitations

BHT-407-FMS-3, Rev. 2, dated 4 September 1998

BHT-407-FMS-4, Rev. 2, dated 4 September 1998

BHT-407-MM-10, Rev. 7, 01 May 1998

Chapter 95, Instruments

BHT-407-IPB, Reissue, 18 May 1999

Chapter 95, Instruments

**ACCOMPLISHMENT INSTRUCTIONS:**

**Part 1 : S/N 53000 through 53424**

- NOTE -

If operators obtain a P/N 407-375-007-105 indicator prior to the date of compliance of Part 1 of this bulletin, install in accordance with standard Maintenance Manual procedures. In addition, BHT-407-FM-1 Revision 8 must be inserted into the 407 Flight Manual in conjunction with installation of the P/N 407-375-007-105 indicator. If applicable, also insert Particle Separator Flight Manual Supplement BHT-407-FMS-3, Rev. 3 and Snow Deflector Flight Manual Supplement BHT-407-FMS-4, Rev. 3. As this alternate procedure meets the intent of Part 1 and Part 2 of this bulletin, make an entry in the helicopter Historical Records (HR) and in the record of Alert Service Bulletins in the Maintenance Manual to show that the Bulletin has been complied with.

1. Disconnect the helicopter electrical power.

2. Remove the hardware that attaches the instrument panel and tilt it aft to gain access to Fuel Pressure / Ammeter indicator P/N 407-375-007-101 or -103.
3. Disconnect the electrical connector from the back of the Fuel Pressure / Ammeter indicator.
4. Remove the 4 screws which secure the Fuel Pressure / Ammeter indicator to the instrument panel and remove the indicator.

- NOTE -

Ensure glass cover and bezel of indicator are clean prior to application of decal. Glass cover and bezel may be cleaned with a clean soft cloth lightly moistened with a mild solution of soap and water. Remove any soap residue by wiping with a clean soft cloth lightly moistened with water. Wipe with soft dry cloth and allow to dry.

5. Being careful not to touch the cleaned glass cover and bezel of indicator with fingers, apply decal P/N 407-075-024-115 to P/N 407-375-007-101 or -103 indicator as shown in Figure 1. Apply decal on the glass cover and bezel of the indicator, over the 170 ampere position. Once decal is confirmed to be located in the proper position use finger pressure to ensure decal is securely adhered.
6. With reference to Figure 2, use a ball point pen to notate identification plate P/N 100-088-1 as shown. The notated 100-088-1 plate will be used to reidentify the indicator to P/N 407-075-024-101 or -103.

- NOTE -

Use a soft clean cloth lightly moistened with aliphatic naphtha (C-305) to clean aft cover of indicator. Allow to dry.

7. Peel off protective backing from notated identification plate and adhere to instrument as shown in figure 2.
8. Using a ballpoint pen, put a line through the P/N 407-375-007-101 or -103 displayed on the indicators original data plate.
9. Install modified Fuel Pressure / Ammeter indicator to instrument panel with 4 screws. Install electrical connector to indicator.

10. Use the hardware you removed to close the instrument panel.
11. Apply electrical power and confirm Fuel Pressure / Ammeter indicator completes power up self-test.
12. Insert the following revisions into the 407 Flight Manual:
  - BHT-407-FM-1, Rev. 8, dated 17 April 2000
  - BHT-407-FMS-3, Rev. 3, dated 17 April 2000 (if applicable)
  - BHT-407-FMS-4, Rev. 3, dated 17 April 2000 (if applicable)
13. Make an entry in the helicopter Historical Records (HR) to show that Part 1 of this Alert Service Bulletin is completed.
14. Make an entry in the Record of Alert Service Bulletins in the Maintenance Manual to show that Part 1 of this Alert Service Bulletin is completed.

**Part 2 : S/N 53000 through 53440**

1. Disconnect the helicopter electrical power.
2. Remove the hardware that attaches the instrument panel and tilt it aft to gain access to the Fuel Pressure / Ammeter indicator P/N 407-075-024-101 or -103.
3. Disconnect the electrical connector from the back of the Fuel Pressure / Ammeter indicator.
4. Remove the 4 screws which secure the Fuel Pressure / Ammeter indicator to the instrument panel and remove the indicator.
5. Install Fuel Pressure / Ammeter indicator P/N 407-375-007-105 or subsequent, to instrument panel with 4 screws. Install electrical connector to indicator.
6. Use the hardware you removed to close the instrument panel.
7. Apply electrical power and confirm Fuel Pressure / Ammeter indicator completes power up self-test.
8. Make an entry in the helicopter Historical Records (HR) to show that Part 2 of this Alert Service Bulletin is completed.
9. Make an entry in the Record of Alert Service Bulletins in the Maintenance Manual to show that Part 2 of this Alert Service Bulletin is completed.

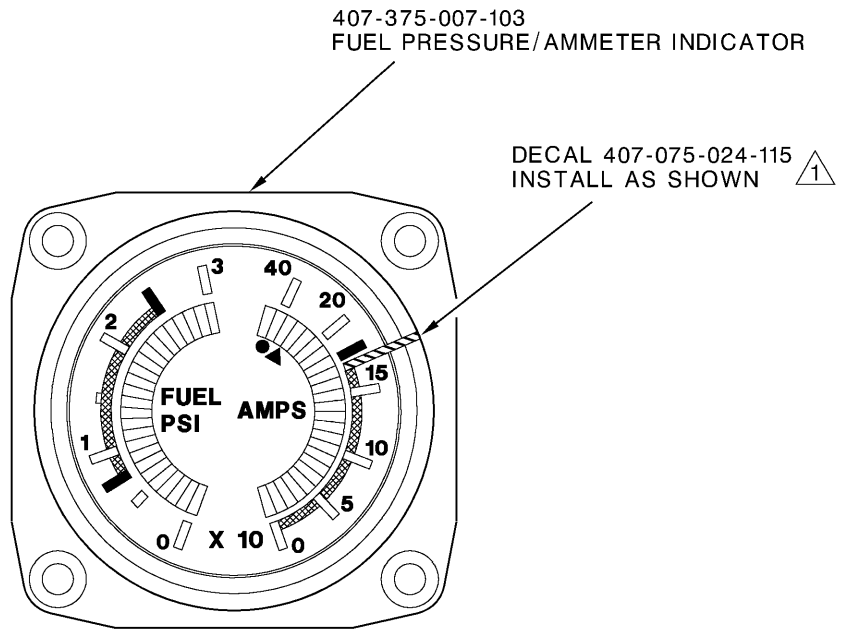
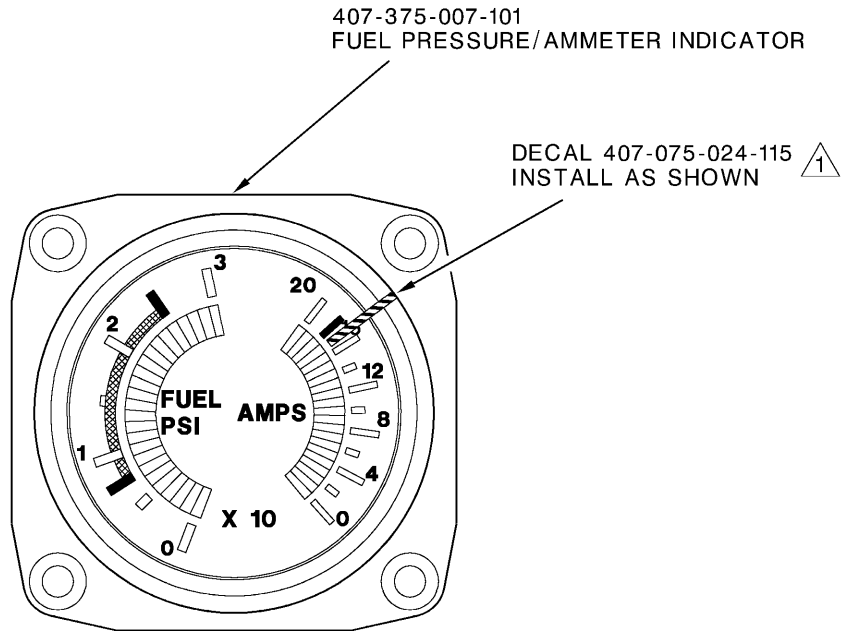

**NOTE**

 Install decal in appropriate position for indicator part number.

**Figure 1. Addition of Decal at 170 Ampere Position on Indicator**

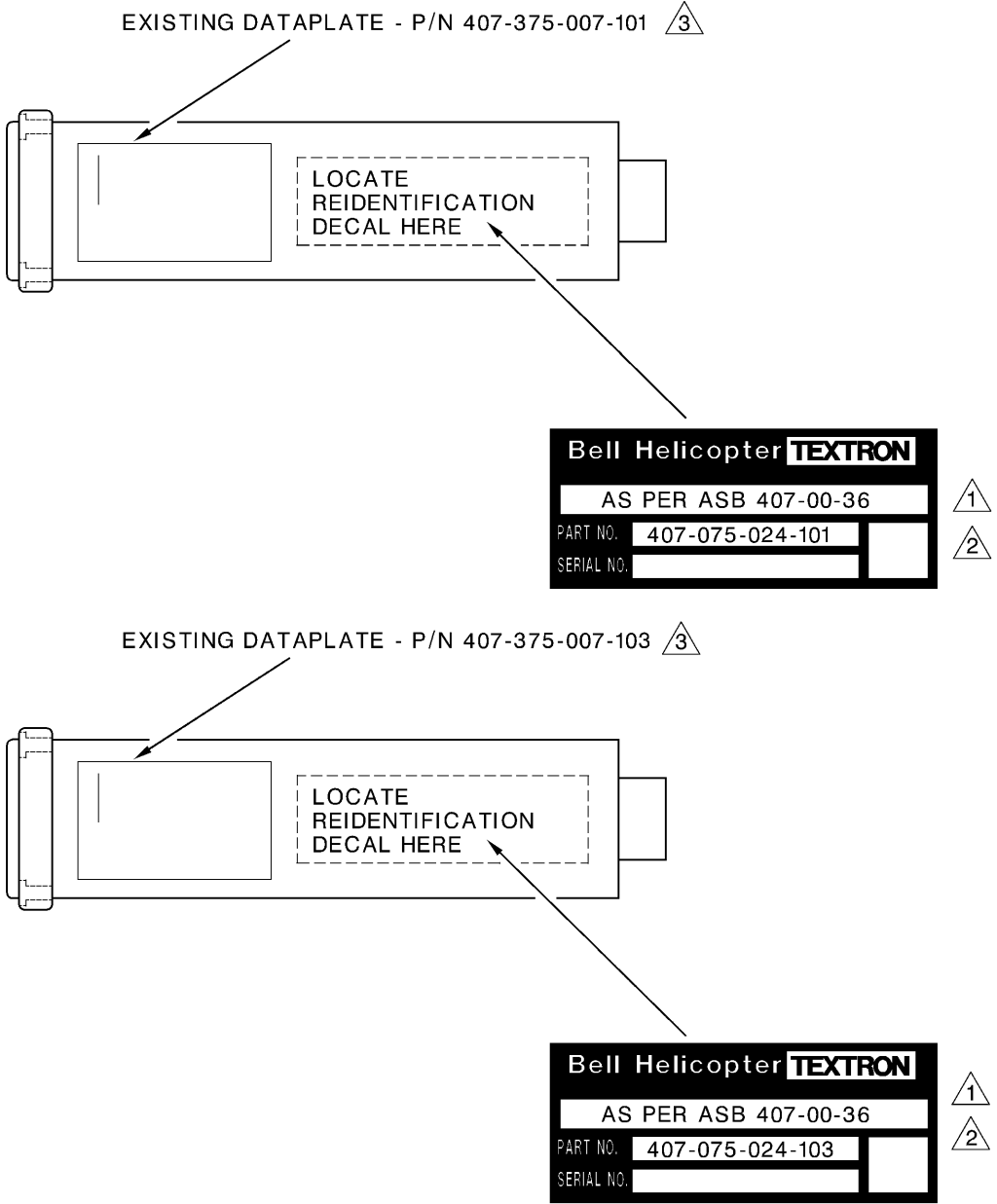

**NOTES**

- 1 Reidentification plate P/N 100-088-1 is provided blank
  - Prior to installation, notate plate as shown for applicable indicator with ball point pen.
  - Use sufficient pen pressure to indent notation on plate.
  - Include existing serial number of indicator in space provided.
- 2 After plate has been notated, peel off protective backing and install plate on instrument in location shown.
- 3 Use ball point pen to put single line through original part number of indicator in location shown.

**Figure 2. Instrument Reidentification**