

ALERT SERVICE BULLETIN



A Textron Company

NO. 407-10-93

DATE May 03, 2010

PAGE 1 of 9

DATE
REV

MODEL AFFECTED: 407

SUBJECT: TAILBOOM ATTACHMENT HARDWARE,
REPLACEMENT OF.

HELICOPTERS AFFECTED: 407 Helicopters serial number 53000 through 53990.

407 helicopters serial number 53991 and subsequent will have the intent of this bulletin accomplished prior to delivery.

COMPLIANCE: For helicopters with cumulative flight time of 7,000 flight-hours or less: Accomplish this bulletin at the next 600 Hours scheduled inspection but no later than December 31st, 2010.

For helicopters with cumulative flight time of more than 7,000 flight-hours: Accomplish this bulletin within 150 hours or 90 days, whichever comes first, following release date of this bulletin.

DESCRIPTION:

Bell Helicopter has reviewed the tailboom attachment installation of the Model 407. It has been determined that the torque values specified in the maintenance manual and used during assembly of the 407 for the tailboom attachment bolts exceed the specified torque range recommended for subject bolts.

This bulletin mandates the removal of the existent tailboom attachment hardware and the installation of new hardware with reduced torque values. In addition, specific hardware installation/torquing procedure is provided for the tailboom to aft fuselage joint.

APPROVAL:

The engineering design aspects of this bulletin are Transport Canada Civil Aviation (TCCA) approved.

MANPOWER:

Approximately 2.0 man-hours are required to complete this bulletin. Man-hours are based on hands-on time, and may vary with personnel and facilities available. This time estimated does not include the torque checks required and defined in the **“SPECIAL INSPECTIONS”** section of this bulletin.

WARRANTY:

Owners / Operators of Bell Helicopters who comply with the instructions in this Bulletin will be eligible to receive a credit for the replacement parts outlined in the materials section of this bulletin.

To receive this credit:

- Comply with the instructions contained in this Bulletin no later than the applicable hours in the “compliance section” of this ASB, or before December 31st, 2010.
- Purchase replacement parts as required in the materials section of this bulletin from a Bell approved source.
- Submit an MMIR to the Bell Warranty Department.

Customers who fail to comply with the instructions in this Bulletin after December 31st, 2010 are not eligible for the special warranty credit listed above. There is no labor credit associated with this bulletin.

MATERIAL:

Required Material:

The following material is required for the accomplishment of this bulletin and may be obtained through your Bell Helicopter Textron Supply Center.

<u>Part Number</u>	<u>Nomenclature</u>	<u>Quantity</u>
NAS627-30	Bolt	2
42FLW-720	Nut	2
NAS626-26	Bolt	2
42FLW-624	Nut	2

Consumable Material:

The following material is required to accomplish this bulletin, but may not require ordering, depending on the operator's consumable material stock levels. This material may be obtained through your Bell Helicopter Textron Supply Center.

<u>Part Number</u>	<u>Nomenclature</u>	<u>Quantity</u>	<u>Reference</u>
CA1000 6OZ	Anti-corrosion compound	1	C-586(Note 1)

Note 1: Mastinox 6858KD (C-128) can be used as an alternate as prescribed in the current maintenance manual. This product can be obtained from BHT-approved supply sources under P/N XMAS6856K/160CTG.

SPECIAL TOOLS:

Socket P/N 407-230-001-101

Note: This socket is required to torque the upper left tailboom attachment hardware (nut) and one unit is delivered with every new ship from factory.

WEIGHT AND BALANCE:

Not affected

ELECTRICAL LOAD DATA:

Not affected

REFERENCES:

BHT-407-IPB Illustrated Parts Breakdown
 BHT-407-MM Maintenance Manual
 BHT-ALL-SPM Standard Practices Manual

PUBLICATIONS AFFECTED:

BHT-407-MM Maintenance Manual

ACCOMPLISHMENT INSTRUCTIONS:

Preparation of helicopter.

1. Remove the access cover from the right aft fuselage to gain access to the tailboom attachment hardware. Retains screws for reinstallation of the cover later.
2. Support weight of the tailboom with an appropriate support device or stand.

Replacement of tailboom attachment bolts and nuts;

NOTE

To prevent using the discrepant hardware again, it is recommended to use a hacksaw or an equivalent tool and make a .125 to .250 inch (3.175 to 6.35 mm) deep cut at any location on the bolt (1) and the nut (2) you will removed before discarding.

1. (Ref. Figure 1) Remove left upper attachment bolt (1) and nut (2) but retain the chamfered washer (4) and the regular washers (3). Discard the nut (2) and the bolt (1) you have removed.

NOTE

Replacement hardware (bolt (1) and nut (2)) shall be new. Hardware with unknown origin should not be used and must be discarded appropriately to prevent further usage.

2. Install a new bolt (1) procured from a BHT-Approved supply source as follows:
 - a) Coat the shank of the new bolt (1) and the faying surfaces of the chamfered washer (4) with anti-corrosion compound (C-586). Do not apply compound on any threads of the bolt (1).
 - b) Fit the new bolt (1) (with the chamfered washer (4) against head of bolt (1)) through the tailboom and the fuselage upper mating fittings.
 - c) Select a sufficient number of washers (3) for opposite end of bolt (1) to obtain a minimum of 1 to a maximum of 3 threads showing beyond the nut (2) after proper torque is obtained. Coat the faying surfaces of these washers (3) with anti-corrosion compound (C-586) and fit over shank of the new bolt (1).

NOTE

Upper nut (2) must have a minimum tare value of 14 inch/lbs (1.58 Nm) or more.

3. Install a new nut (2) on the forward end of the bolt (1) as follows;
 - a) Coat the nut (2) faying surface prior to assembly. Do not apply compound on any threads of the nut (2).
 - b) Run the nut (2) on the threads of the mating bolt (1) with a dial indicator type torque wrench and measure existing tare.
 - c) Torque the nut (2) between 570 to 580 inch/lbs (64.4 to 65.5 Nm) of torque plus the tare of the nut (2), using socket P/N 407-230-001-101 or equivalent tool.
 - d) Back off nut (2) at least a minimum of $\frac{3}{4}$ of a turn before re-applying the same torque between 570 to 580 inch/lbs (64.4 to 65.5 Nm) plus the existing tare of the nut (2).
 - e) Coat bolt (1) head, nut (2) and washers (3, 4) with anti-corrosion compound (C-586).
4. Repeat Steps 1 through Step 3 for the opposite right upper bolt (1) and mating nut (2).

NOTE

To prevent using the discrepant hardware again, it is recommended to use a hacksaw or an equivalent tool and make a .125 to .250 inch (3.175 to 6.35 mm) deep cut at any location on the bolt (10) and the nut (7) you will removed before discarding.

5. (Ref. Figure 1) Remove left lower attachment bolt (10) and nut (7) but retain the chamfered washers (8) and the regular washers (9). Discard the nut (7) and the bolt (10) you have removed.

NOTE

Replacement hardware (bolt (10) and nut (7)) shall be new. Hardware with unknown origin should not be used and must be discarded appropriately to prevent further usage.

6. Install a new bolt (10) procured from a BHT-Approved supply source as follows:
 - a) Coat the shank of the new bolt (10) and the faying surfaces of the chamfered washer (8) with anti-corrosion compound (C-586). Do not apply compound on any threads of the bolt (10).

- b) Fit the new bolt (10) (with the chamfered washer (8) against head of bolt (10)) through the tailboom and the fuselage lower mating fittings.
- c) Select a sufficient number of washers (9) for opposite end of bolt (10) to obtain a minimum of 1 to a maximum of 3 threads showing beyond the nut (7) after proper torque is obtained. Coat the faying surfaces of these washers (9) with anti-corrosion compound (C-586) and fit over shank of the new bolt (10).

NOTE

Lower nut (7) must have a minimum tare value of 9.5 inch/lbs (1.07Nm) or more.

- 7. Install a new nut (7) on the forward end of the bolt (10) as follows;
 - a) Coat the nut (7) faying surface prior to assembly. Do not apply compound on any threads of the nut (7).
 - b) Run the nut (7) on the threads of the mating bolt (10) with a dial indicator type torque wrench and measure existing tare.
 - c) Torque the nut (7) between 360 to 370 inch/lbs (40.6 to 41.8 Nm) of torque plus the tare of the nut, (7) using proper tool.
 - d) Back off nut (7) at least a minimum of $\frac{3}{4}$ of a turn before re-applying the same torque between 360 to 370 inch/lbs (40.6 to 41.8 Nm) plus the existing tare of the nut (7).
 - e) Coat bolt (10) head, nut (7) and washers (8, 9) with anti-corrosion compound (C-586)
- 8. Repeat Steps 5 through Step 7 for the opposite right lower bolt (10) and nut (7).
- 9. Reinstall aft fuselage access cover using the screws retained earlier.
- 10. Annotate technical records to indicate replacement of the tailboom assembly attachment hardware in compliance with this bulletin.

SPECIAL INSPECTION:

Torque check 1 to 5 flight hours following initial installation:

NOTE

For torque check purposes, the assembly torque to be applied is the minimum specified torque (see Figure 1) plus

the minimum acceptable tare torque of 14 inch/lbs(1.58 Nm) for the upper nuts (2) and 9.5 inch/Lbs (1.07Nm) for the lower nuts(7).

1. Torque check the upper and lower nuts (2, 7) as per procedure found in Chapter 2 of the Standard Practices Manual every 1 to 5 flight hours until torque stabilized.
2. Annotate technical records to indicate compliance with this special inspection.

SCHEDULED INSPECTION:

Recurring torque check every 300 hours of operations.

NOTE

For torque check purposes, the assembly torque to be applied is the minimum specified torque (see Figure 1) plus the minimum acceptable tare torque of 14 inch/lbs(1.58 Nm) for the upper nuts (2) and 9.5 inch/Lbs (1.07Nm) for the lower nuts(7).

1. (Ref. BHT-ALL-SPM, Chapter 2)Gain access and perform a recurring torque check at all four attachment positions;
 - a) Attachment that has not retained proper torque will require disassembly and inspection. The assembly shall be inspected for damage, corrosion, improper assembly, and condition.
 - b) The mating hardware (fastener(s) and nut (s)) must be replaced with new one(s) and torqued to the Assembly Torque value following the procedure outline in this bulletin.
 - c) The affected hardware(s) would have to be Torque Checked again at the same scheduled intervals (special inspections) set following initial installation.
2. Annotate technical records to indicate compliance with this special inspection.
3. Repeat this torque check at every 300 hours of component operation.

MAINTENANCE OF TAILBOOM HARDWARE:

1. Discard all hardware (mating nuts (2, 7) and bolts (1, 10)) each time the tailboom assembly is removed from or installed on the fuselage;
 - a) Use a hacksaw or an equivalent tool and make a .125 to .250 inch (3.175 to 6.35 mm) deep cut at any location on the bolt (1) and the nut (2) you will removed before discarding.
 - b) Install only new hardware using the procedure outlined in this bulletin.

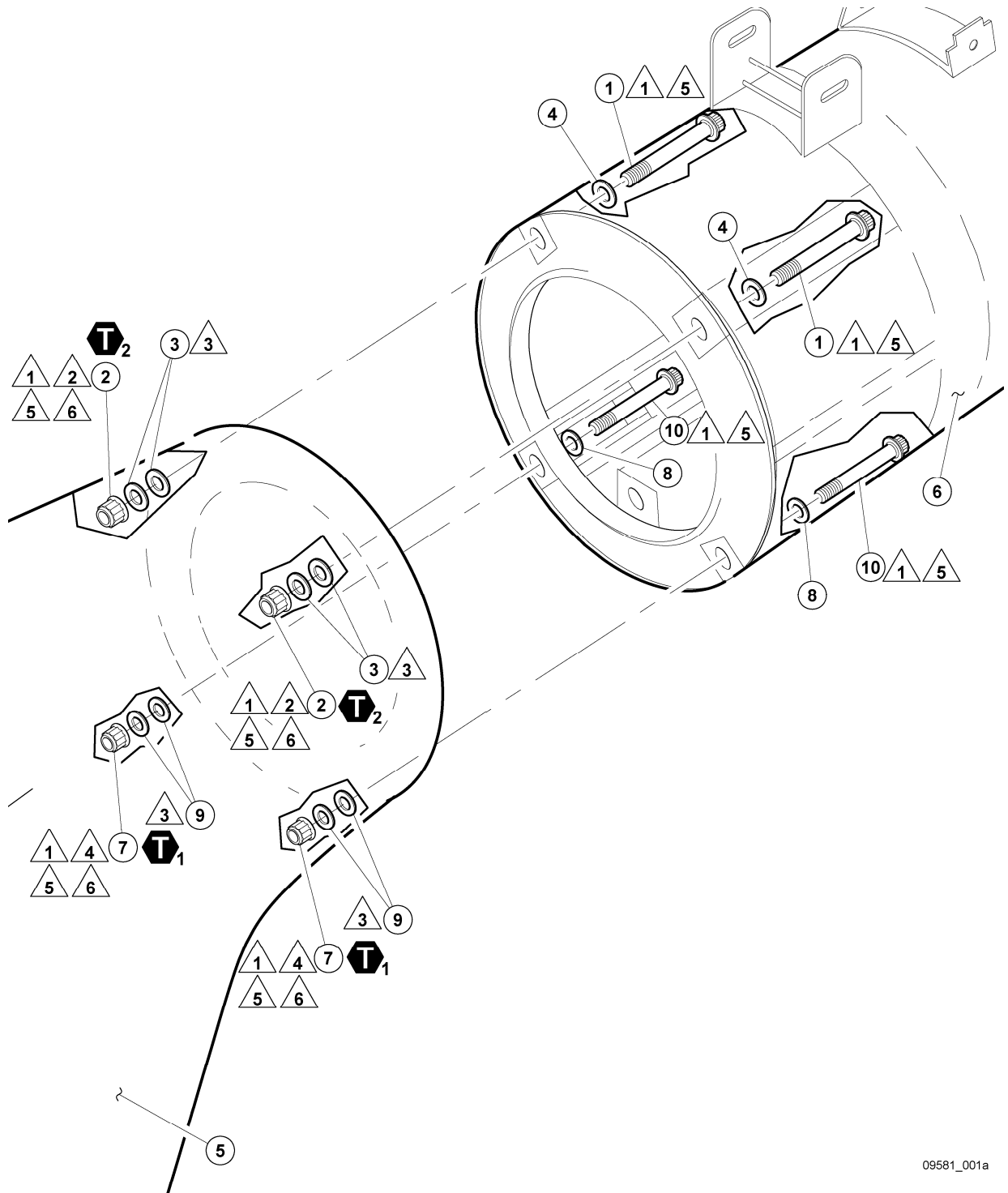



2.

FIGURE 1: Replacement of tailboom upper attachment bolts (Sheet 1 of 2)







LEGEND

1. Upper tailboom attachment bolt NAS627-30
2. Nut 42FLW-720
3. Washer NAS1149G0732P (Ref)
4. Washer 140-007-29S25E6 (Ref)
5. Fuselage (Ref)
6. Tailboom assembly (Ref)
7. Nut 42FLW-624
8. Washer 140-007-25S22E6(Ref)
9. Washer NAS1149G0663P (Ref)
10. Lower tailboom attachment bolt NAS626-26

 360 TO 370 INCH/LBS
(40.6 TO 41.8 Nm)

 570 TO 580 INCH/LBS
(64.4 TO 65.5 Nm)

NOTES

-  Replace existing bolts and nuts by new ones.
-  Upper nut must have tare above minimum value of 14 inch-pounds (1.58 Nm).
-  Adjust quantity of washers to obtain proper safety of nut in accordance with maintenance manual.
-  Lower nut must have tare above minimum value of 9.5 inch-pounds (1.07 Nm).
-  Replace nuts and bolts each time the tailboom is disconnected from the fuselage.
-  Torque nut to indicated value then back off nut a minimum of 3/4 of a turn before retorquing again.
7. Perform torque check 1 to 5 hours after initial installation. Repeat this torque check at repetitive periods between 1 to 5 hours until torques stabilize at all 4 locations.
8. Perform torque check of all hardware every 300 hours of component operation.

09581_001b

FIGURE 1: Replacement of tailboom upper attachment bolts (Sheet 2 of 2)