

ALERT SERVICE BULLETIN



A Textron Company

NO. 412-09-133

DATE Feb 17, 2009

PAGE 1

DATE
REV

MODEL AFFECTED: 412 & 412EP

SUBJECT: INSPECTION/CHANGE OF RESTRAINT SYSTEM ASSEMBLY WITH INERTIA REEL AND MANUAL LOCK HANDLE

HELICOPTERS AFFECTED: All 412 & 412EP helicopters serial numbers 33001 through 33213 and 36001 through 36419 equipped with P/N 412-070-843-105 (AMSAFE P/N 501836-207) Crew Seat Restraint Assembly.

COMPLIANCE: See vendor bulletin

DESCRIPTION:

The purpose of this bulletin is to achieve complete distribution of the attached vendor bulletin to the current affected model distribution list on record at Bell Helicopter.

APPROVAL:

See vendor bulletin

AMSAFE®

Aviation

SERVICE BULLETIN

EQUIPMENT / FURNISHINGS FLIGHT COMPARTMENT

INSPECTION / CHANGE OF RESTRAINT SYSTEM ASSEMBLY
WITH INERTIA REEL AND MANUAL LOCK HANDLE

SERVICE BULLETIN NUMBER 501836-25-01 ISSUE 1

ISSUED BY:
AMSAFE INC.
1043 N. 47th AVENUE
PHOENIX, AZ USA 85043
TEL: (602) 850-2850 FAX: (602) 850-2812

Prepared by:



Jack Riley
Manager, Quality Assurance

1-9-09

Date

Approved by:

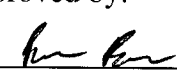

Brian Burns
Engineering Manager

1/9/09

Date

501836-25-01

Page 1 of 9

Issue: 1

Date: 19 December 2008



SERVICE BULLETIN

RECORD OF REVISIONS

Retain this record at the front of the Service Bulletin. On receipt of a revision, amend as instructed in the letter of transmittal and record the incorporation of the revision on this sheet. Retain the letter of transmittal following record.

Issue	Changed by	Revisions	Approved	Release date
1	J. Riley	New document release	JR BB	01/12/09

501836-25-01

Page 2 of 9

Issue: 1

Date: 19 December 2008



SERVICE BULLETIN

1. PLANNING INFORMATION

A. **Affectivity**

This Service Bulletin is applicable to the below cited Restraint Systems incorporating both Inertia Reels and a Manual Lock. The affected part numbers included herein are identified on the product label as follows:

501836-XXX-XXXX

Traceability of affected assemblies is those that have been manufactured between February 07 through November 08 (X0207 through X1108) The date code information is found on the inertia reel identification label.

B. **Classification**

Mandatory

C. **Compliance**

Inspection: AmSafe recommends that the inspection listed in this Service Bulletin be done within 90 days of issue of this Service Bulletin.

Further action: Should further action be required, this must be done immediately. Should the unit function correctly, the unit shall be returned to AmSafe for a component change within 1 year after inspection.

501836-25-01

Page 3 of 9

Issue: 1

Date: 19 December 2008



SERVICE BULLETIN

D. Reason

On 9th February 2007 an inertia reel component was revised to improve the manufacturing capability of the inertia reel assembly. Recent service installation history has revealed a rare interaction of the components due to tolerance issues that were not apparent in the qualification testing of that component. This interaction may cause the assembly to exhibit an inoperable condition on the inertia reel lock system. This Service Bulletin addresses the issue by requiring a mandatory replacement of the subject component / assembly. This replacement component eliminates the root cause of the problem.

E. Description

This Service Bulletin provides instruction for the Inspection of the Restraint System. AmSafe Aviation will stock a number of these assemblies to ensure that turn around will be immediate if needed. Following the Accomplishment Instructions of this Service Bulletin will not change the standard function or performance of the Restraint System.

F. Approval

This Service Bulletin contains no modification information that revises the approval configuration and therefore does not require FAA or other regulatory agency approval. This Service Bulletin has been approved by AmSafe only. The FAA TSO-C114 approval of the Restraint System is unaffected.

G. Manpower

Inspection of the Restraint System is less than 15min per unit, when accomplished at maintenance level. Should removal of the Restraint System from the seat be required, the manpower for this is per the seat manufactures instructions.

501836-25-01

Page 4 of 9

Issue: 1

Date: 19 December 2008



SERVICE BULLETIN

H. Warranty

AmSafe warranty remedies are available for those Restraint System listed in the Affectivity section of this Service Bulletin.

I. Material Cost and Availability

The complete Restraint Systems should be returned to AmSafe authorised repair station together with a Free of Charge purchase order containing the following information:

Part Number and Serial Number / Date Code:
Quantity:
Reference: "Service Bulletin 501836-25-01"
Name of Airline / Operator:
Shipping Address:

Restraint systems should be sent to either of the following locations:

Europe / Asia:

AmSafe Aviation UK
Tamian Way, Green Lane
TW4 6BL
Telephone: +44(0) 208 572 0321
Fax: +44(0) 208 572 2096

North American and other:

AmSafe Inc.
1043 N 47th Ave
Phoenix
Arizona 85043
Telephone: +1(602) 850-2850
Fax: +1(602) 850-2812

501836-25-01

Page 5 of 9

Issue: 1

Date: 19 December 2008



SERVICE BULLETIN

J. Tooling – Price and Availability

A spring balance capable of reading a force of 25lb.
No other special tools, fixtures or equipment are required for the inspection of the restraint system.

K. Weight and Balance

This Service Bulletin has no affect on weight or balance.

L. Electrical Load Data

None

M. Software Accomplishment Summary

None

N. References

AmSafe CMM 25-22-70

O. Other Publications Affected

None

501836-25-01

Page 6 of 9

Issue: 1

Date: 19 December 2008



SERVICE BULLETIN

2. ACCOMPLISHMENT INSTRUCTION

1. The inspection of the restraint system does not require the restraint system to be removed from the seat.
2. Date Code Inspection. The date code can be found on the inertia reel identification label see Figure 1. For access to the inertia reel identification label please refer to the applicable seat manufactures instruction defined in their CMM.

If the date code is prior to 1 Feb 07 (X0207) or after 30 Nov 08 (X1108) no further action is required.

If the serial number is between 1 Feb 07 (X0207) and 30 Nov 08 (X1108), and the inertia reel does not include a label attached by AmSafe stating "Wheel Checked" (Figure 2) continue to step 3.

Important Note:

Although the lap belt and crotch strap assemblies also carry a serial number, these cannot be used as the lap belts or shoulder harness assembly (one or the other) may have been replaced by an airline operated during maintenance of the restraint systems.

3. Inspect the restraint for continued airworthiness by:
 - Extending at least 18" of webbing, but not fully extending the webbing.
 - Activate the manual lock by operating the manual lock handle.
 - Apply approximately 10 - 15 lbs of pulling force to the webbing and observe that no more than 1" of webbing can be extended.
 - Deactivate the manual lock by operating the manual lock handle. Accelerate (pull) webbing to verify that the inertia lock features of the shoulder harness reel also lock the webbing and with 10 - 15 lbs of pulling force to the webbing observe that no more than 1" of webbing can be extended. Repeat 3 times at different extensions of webbing.

501836-25-01

Page 7 of 9

Issue: 1

Date: 19 December 2008

SERVICE BULLETIN

Should any of the above tests fail the unit should be returned to AmSafe for immediate rectification. Removal of the restraint system from the seat must be done in accordance with the seat manufactures CMM and restraint system shipped back to AmSafe Aviation (see section 1. I (Material and Cost Availability).

4. Should the restraint system shoulder harness pass the above tests described in step 3 then
 - Permanently mark the shoulder harness inertia reel identification label with the Service Bulletin number and date actioned i.e. “SB 501836-25-01 + Date”
 - This restraint system should be returned to AmSafe Aviation for rectification within 1 year as defined in Section 1.C Compliance.

Important Note

All restraint systems, within the date/serial number codes described in section 2.2, passing the inspection tests are still required to be replaced within the defined time period.

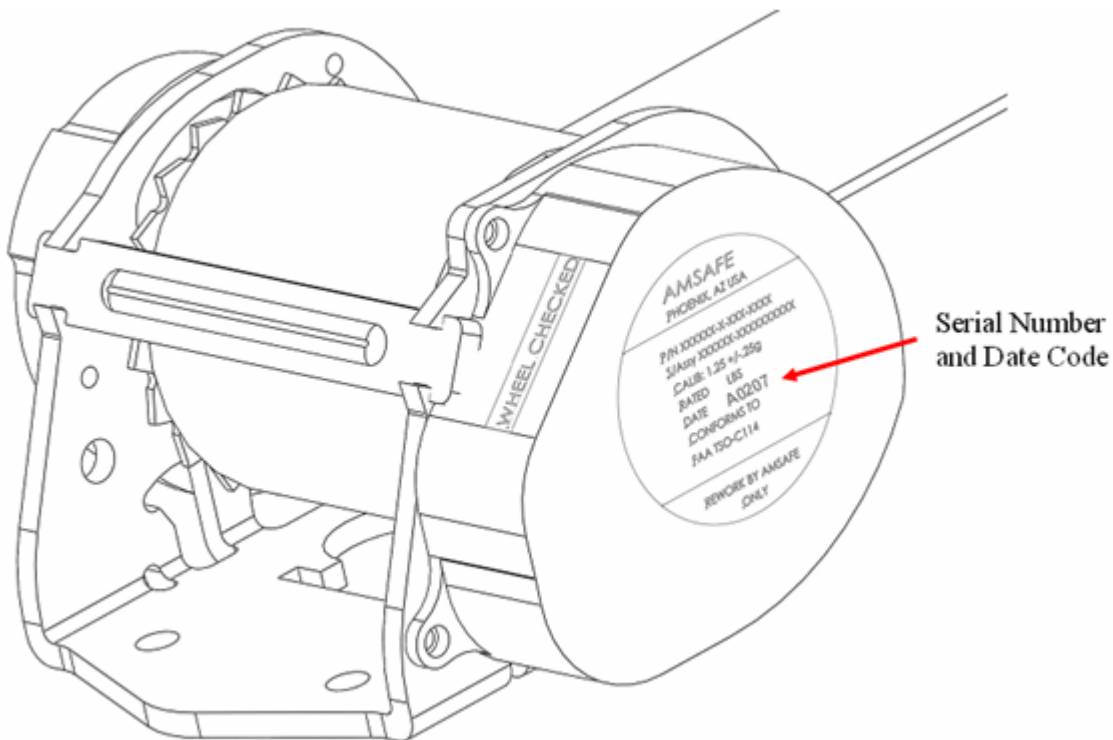

Figure 1 – Serial Number and Date Code Information

SERVICE BULLETIN

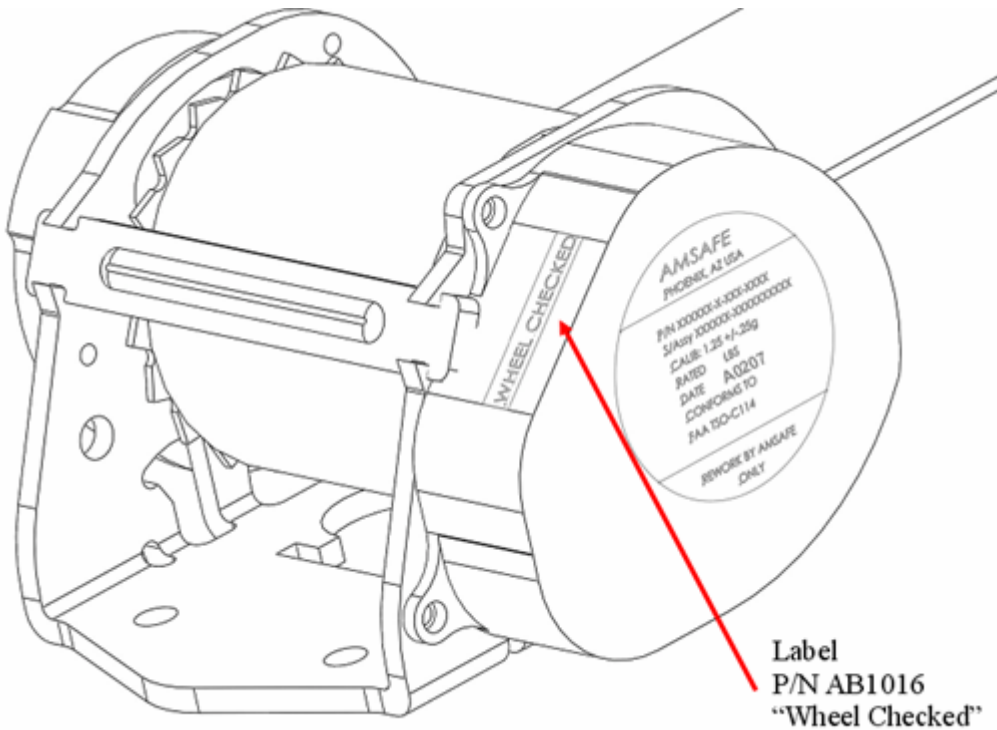

Figure 2 – Wheel Checked Label