

**ALERT SERVICE BULLETIN**



NO. 412-10-139  
DATE Jan 11, 2010  
PAGE 1 of 7

DATE
REV

**MODEL AFFECTED:** 412 & 412EP

**SUBJECT:** Inspection of Transmission Oil Line P/N 70-061L000V360A for Correct Length.

**HELICOPTERS AFFECTED:** Model 412 helicopters serial number 33001 through 33213, 34001 through 34036, and 36001 through 36540.

[Model 412 helicopters serial number 33214 and subsequent, and 36541 and subsequent will have the intent of this bulletin accomplished prior to delivery.]

**COMPLIANCE:** Within 300 Hours after receipt of this bulletin but no later than August 31 2010.

**DESCRIPTION:**

Bell Helicopter has been made aware that incorrect transmission Hose Assemblies P/N 70-061L000V360A may have been installed on delivered aircraft and could be the incorrect length for the intended application. Although the hose specification requirement for the hose assembly 70-061L000V360A calls for total length of 36 inches plus or minus 0.5 inch, the correct installation requires a hose length of 37 inches plus or minus 0.5 inch. Some installed hoses meet this 37 inch requirement while others are too short. This bulletin replaces short hoses or re-identifies hoses that are of correct length.

**APPROVAL:**

The engineering design aspects of this bulletin are FAA/ODA approved.

**MANPOWER:**

Approximately 2.0 man-hours are required to complete this bulletin. Man-hours are based on hands-on time, and may vary with personnel and facilities available.

**WARRANTY:**

Owners / Operators of Bell Helicopters who comply with the instructions in this Bulletin will be eligible to receive a warranty credit for the replacement Hose Assembly part number 70-061L000V370A as outlined in the required materials section of this Bulletin.

To receive this credit:

- Purchase the required part number 70-061L000V370A Hose Assembly from an approved Bell Helicopter supply source.
- Comply with the instructions contained in this Bulletin no later than the applicable hours in the “compliance section” of this ASB, or before August 31 2010.

There is no labor associated with this bulletin.

**MATERIAL:**

**Required Material:**

The following material may be required for the accomplishment of this bulletin and may be obtained through your Bell Helicopter Textron Supply Center.

<u>Part Number</u>	<u>Nomenclature</u>	<u>Quantity</u>
70-061L000V370A	Hose Assy	1

**Consumable Material:**

None required

**SPECIAL TOOLS:**

None required

**WEIGHT AND BALANCE:**

Not effected

**ELECTRICAL LOAD DATA:**

Not affected

**REFERENCES:**

BHT-412-IPB Illustrated Parts Breakdown

BHT-412-MM Maintenance Manual

**PUBLICATIONS AFFECTED:**

None affected

**ACCOMPLISHMENT INSTRUCTIONS:**

1. Make helicopter ready for maintenance.
2. Remove pylon fairings.
3. Remove the transmission cowlings.
4. Remove the lower access panel on the front side of the pylon.
5. Remove the Hose Assembly part number 70-061L000V360A running from the external oil filter to the transmission pressure manifold.
6. Identify the Hose Assembly part number from the metal tag attached to the Hose Assembly. If the identification tag cannot be found replace the Hose Assembly with a new part number Hose Assembly 70-061L000V370A.
7. Lay the Hose Assembly on a flat surface and measure the length of the Hose as detailed in Figure 1.
8. If the part number 70-061L000V360A Hose Assembly is 36.5 inches (92.71 cm) to 37.5 inches (95.25 cm) then the Hose Assembly must be re-identified, as detailed in step 9.
9. Using a vibrating stylus, vibro-etch a single line through the last four characters of the part number 70-061L000V360A on the tag. Then re-identify the part number of the Hose Assembly as 70-061L000V370AFM.

10. If the Hose Assembly part number 70-061L000V360A measures less than 36.5 inches (92.71 cm) it must be replaced by new part number 70-061L000V370A Hose Assembly prior to further flight.
11. Hoses measuring more than 37.5 inches (95.25 cm) must be replaced by new part number 70-061L000V370A Hose Assembly prior to further flight.
12. Re-install the Hose Assembly and ensure there is no fowling between the Hose Assembly and any airframe components, drive system components, and wiring on the aircraft. See Figure 2 and view "A" for the correct routing of the Hose Assembly.

**WARNING**

Failure to properly install, align and torque the transmission Hose Assembly could lead to the loss of transmission lubricating oil.

13. Re-install the lower access panel on the front side of the pylon.
14. Start the aircraft.
15. Carry out a leak check.
16. Shut down the aircraft.
17. Remove the lower access panel on the front side of the pylon.
18. Check for leaks on the Hose Assembly part number 70-061L000V370A or 70-061L000V370AFM depending on the part number installed.
19. Re-install the lower access panel on the front side of the pylon.
20. Re-install the transmission cowlings.
21. Re-install the pylon fairings.
22. Make an entry in the helicopter historical records to show that ASB 412-10-139 has been complied with.

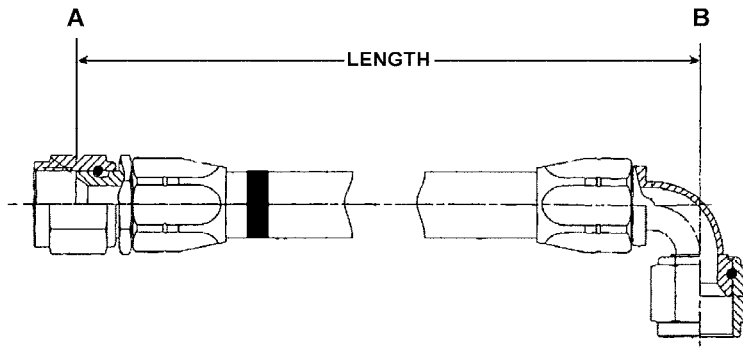

09574\_002

FIGURE 1

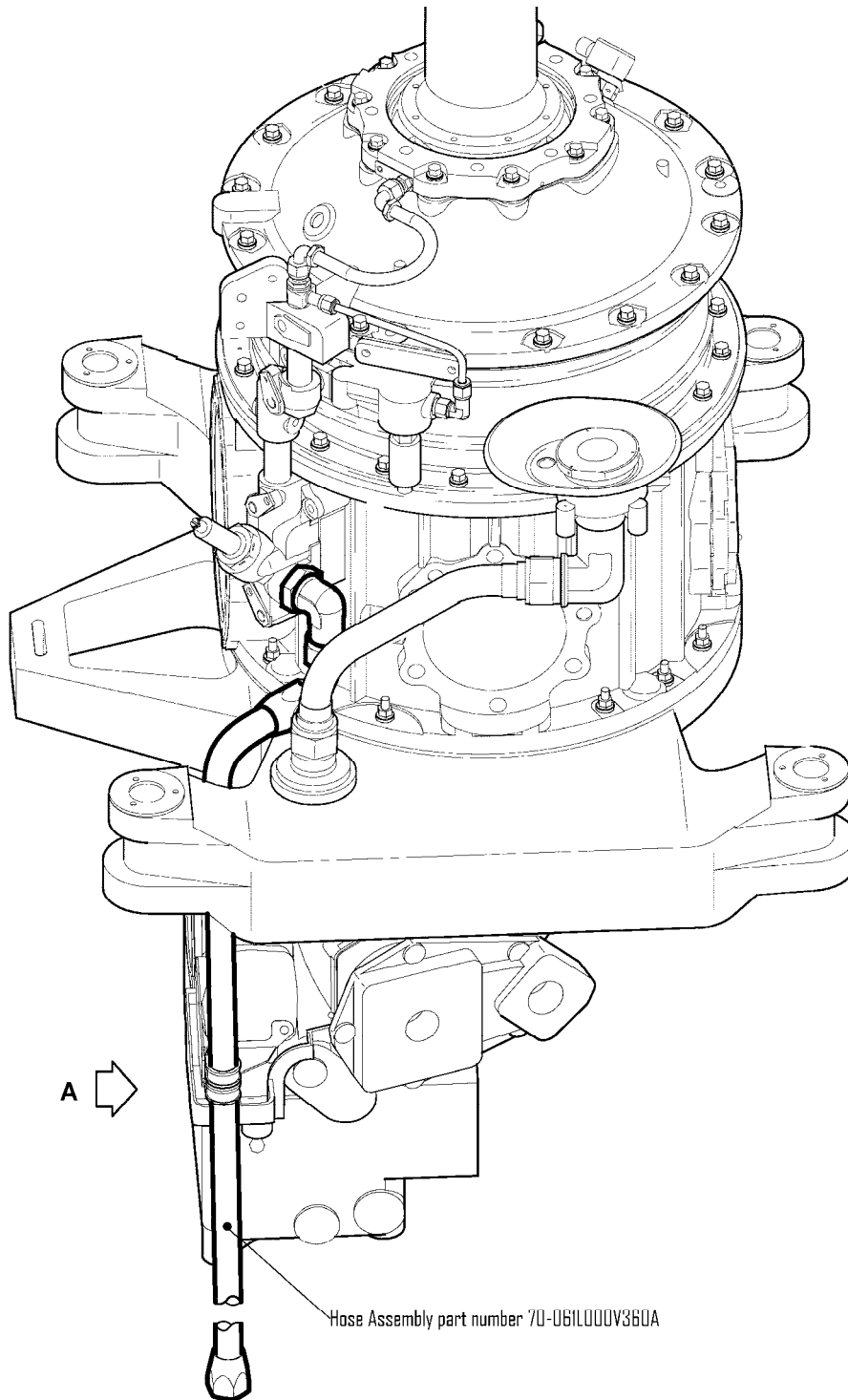

09574\_001

FIGURE 2

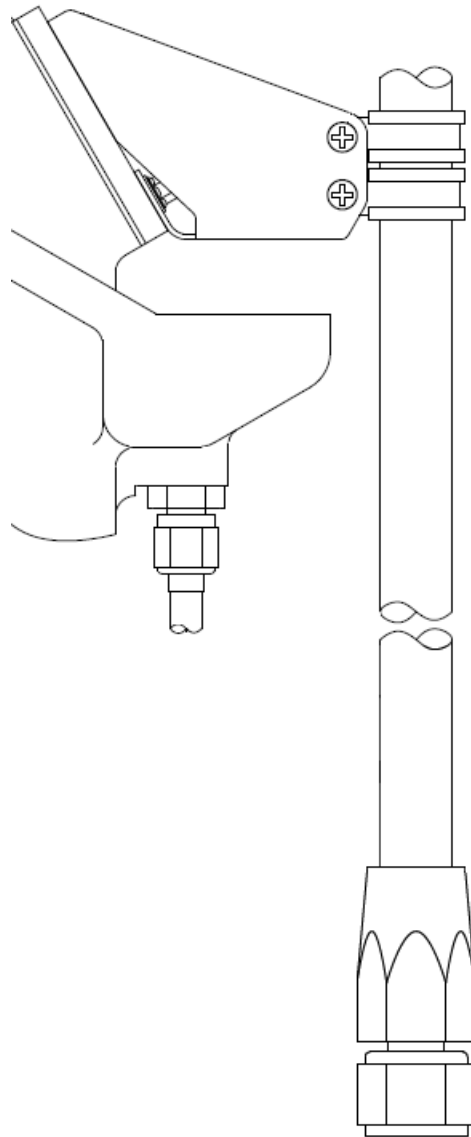

VIEW A