



A Textron Company

ALERT SERVICE BULLETIN

412CF-11-47

15 September 2011

Revision A, 12 December 2011

MODEL AFFECTED: 412CF

SUBJECT: COLLECTIVE LEVER 412-010-408-101, 100 HOUR SPECIAL INSPECTION INTRODUCTION OF

HELICOPTERS AFFECTED: Serial number 46400 through 46499.

[Serial numbers 46500 and subsequent will have the intent of this bulletin accomplished prior to delivery. Recurring inspection will be required as indicated in the COMPLIANCE section]

COMPLIANCE: Within the next 100 hours accumulated on the collective lever or 90 days after release of this bulletin whichever comes first and every 100 hours accumulated on the collective lever thereafter.

DESCRIPTION:

Revision A allows the lower side of the collective lever to be visually inspected with a mirror (no magnifying glass) due to difficult access. Other changes are also incorporated for clarity.

Bell Helicopter has received a report of a fractured collective lever 412-010-408-101. The investigation has revealed that residual stresses induced during manufacturing may have contributed to the fatigue fracture. This anomaly in the forging that could lead to cracking cannot be detected using existing Non Destructive Inspection methods. This Alert Service Bulletin introduces a recurring 100 hrs 10 X magnifying glass inspection of the collective lever. The Maintenance Manual will be revised to include the intent of this Alert Service Bulletin as a 100 hour Special Inspection (Mandatory Structural Inspection). Applicability of this bulletin to any spare part shall be determined prior to its installation on an affected helicopter.

APPROVAL:

The engineering design aspects of this bulletin are FAA/ODA approved.

CONTACT INFO:

For any questions regarding this bulletin, please contact:

Bell Helicopter Product Support Engineering - Medium Helicopters
Tel: 450-437-6201 / 1-800-363-8028 / psemedium@bellhelicopter.textron.com

MANPOWER:

The man-hours required to complete this bulletin are negligible. This estimate is based on hands-on time, and may vary with personnel and facilities available.

WARRANTY:

There is no warranty credit applicable for parts or labor associated with this bulletin.

MATERIAL:

Required Material:

The following material may be required for the accomplishment of this bulletin and may be obtained through your Bell Helicopter Textron Supply Center.

<u>Part Number</u>	<u>Nomenclature</u>	<u>Qty</u>
412-010-408-101	Collective lever assembly	(Note)

Note: Ordering will be required only if a crack is found.

Consumable Material:

The following material is required to accomplish this bulletin, but may not require ordering, depending on the operator's consumable material stock levels. This material may be obtained through your Bell Helicopter Textron Supply Center.

<u>Part Number</u>	<u>Nomenclature</u>	<u>Qty</u>	<u>Reference *</u>
MILC87936TYI	Cleaning Compound	A/R	C-318

* C-XXX numbers refer to the consumables list in BHT-ALL-SPM Standard Practices Manual

SPECIAL TOOLS:

None required.

WEIGHT AND BALANCE:

Not affected.

ELECTRICAL LOAD DATA:

Not affected.

REFERENCES:

C-12-146-000/MF-001 CH146 Maintenance Manual.
BHT-ALL-SPM

PUBLICATIONS AFFECTED:

C-12-146-000/MF-001 CH146 Maintenance Manual.

ACCOMPLISHMENT INSTRUCTIONS:

Collective lever inspection.

1. Prepare helicopter for maintenance.
 - a. Gain access to the collective lever.
2. Using cleaning compound (C-318) or equivalent, thoroughly clean the collective lever in preparation for inspection.
3. Using a strong light source and a 10X magnifying glass, inspect the collective lever in the areas shown on Figure 1. Due to difficult access, it is acceptable to inspect the lower side of the affected area with a strong light source and a mirror only.
4. Look for evidence of crack in the paint.
5. If a crack is suspected, remove the collective lever from the swashplate assembly. (BHT-412-MM)
 - a. Perform a Fluorescent Penetrant Inspection with local paint and primer removed in the suspected area. (BHT-ALL-SPM.
6. If a crack is found, replace the collective lever with a serviceable part and contact Product Support Engineering to report the defect.
7. If no crack is found, refinish as required per BHT-412-CR&O and make an entry in the helicopter records to indicate findings and compliance with this Alert Service Bulletin.

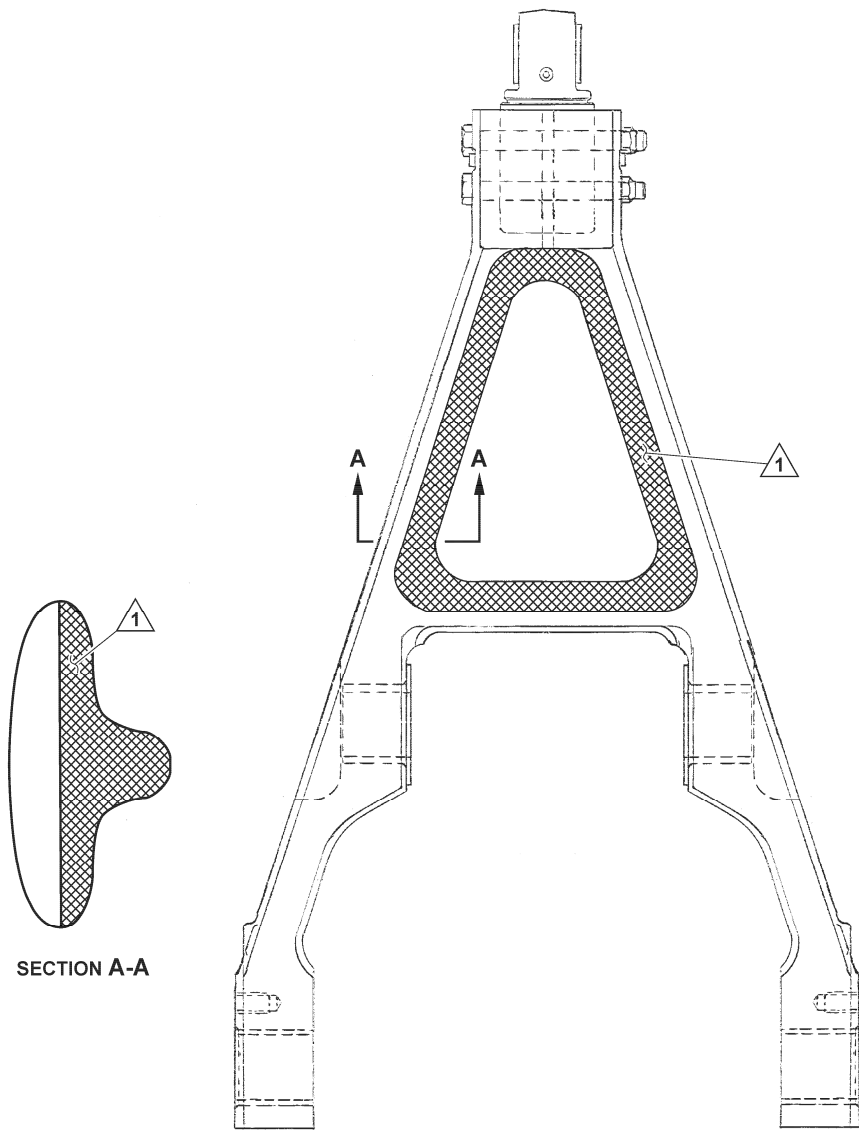

SECTION A-A

NOTE

① Area to be inspected with a 10X power magnifying glass. Due to difficult access, it is acceptable to inspect the lower side of the affected area with a strong light source and a mirror only.

11539_001

Figure 1. Collective lever inspection.