

ALERT SERVICE BULLETIN



A Textron Company

NO. 427-09-28

DATE Oct 07, 2009

PAGE 1 of 1

DATE
REV

MODEL AFFECTED: 427

SUBJECT: HYDRAULIC SERVOACTUATOR P/N 206-076-062-111, INSPECTION OF

HELICOPTERS AFFECTED: Model 427 helicopters serial number 56001 through 56073, 56077, 58001, 58002 and all spares.

Model 427 helicopters serial numbers 56074 through 56076, 56078 and subsequent and 58003 and subsequent will have the intent of this bulletin accomplished prior to delivery.

COMPLIANCE: See vendor bulletin.

DESCRIPTION:

The purpose of this bulletin is to achieve complete distribution of the attached vendor bulletin to the current affected model distribution list on record by Bell Helicopter.

APPROVAL:

See vendor bulletin approval.

ALERT SERVICE BULLETIN

FLIGHT CONTROLS – HYDRAULIC SERVOACTUATOR, PART NUMBER
41011300-103-101

1. Planning Information

A. Effectivity

This service bulletin applies only to hydraulic servoactuator 41011300-101 and -103 prior to serial number HR1117 (Bell Helicopter part number 206-076-062-105 and -111) used on Bell model 407 and 427 aircraft and provides notice of a one time inspection requirement for a possible adverse tolerance condition. In addition, this bulletin provides remedy instructions.

B. Reason

A small number of hydraulic servoactuators 41011300-103 have been discovered with limited clearance between two bolt flanges on output end assembly 41009852-101 or -102 and spacer 41003289. This limited clearance has the potential to create increased pilot input force (see Figures 1 and 2).

Output end assembly 41009852-101 and -102 are built using Output End 41009851-001 or -002, which are made from an aluminum forging 41009471-001 or 41009471. The ensuing investigation found flange height had not been controlled adequately on component drawings, in particular improper control of the forging draft angle.

This issue has been remedied for all new production actuators 41011300-103 Serial numbers HR1117 and later by establishing a “straight cut” with Output End 41009851-001 or -002 “Rev B” that provides adequate clearance. Fielded units and spares will be addressed by the actions of this bulletin.

The 41009852-101 and -102 Output End have been in production since 1993 without incident. This success is attributable to multiple inspections and operational test redundancies during actuator manufacture and assembly. Pilot input operation at the actuator level is thoroughly screened during acceptance testing notably during full stroke capability, servo bypass valve function and pilot input force tests. In addition boost-on and boost-off preflight checks are in place at the aircraft level to ensure proper actuator operation.

C. Description

Any fielded unit that exhibits pilot input anomalies traceable to actuator function will be immediately returned to the manufacturer or authorized repair facility before further flight. Anomalies would include limited pilot input travel in which the Servo-Bypass-Valve is unable to engage or increased pilot input force. Indications tracing these anomalies to actuator function would include scuff marks or other signs of

ALERT SERVICE BULLETIN

contact or abrasion on either of the two spacers 41003289 curved surfaces in proximity to limited clearance with one of the output end bolt flanges.

All fielded units, on aircraft or spares, with Output Ends 41009851-001 or -002 prior to "Rev B", despite functioning properly during ATP or preflight checks will be inspected at 2 places for a minimum clearance of 0.003 inch between spacer and flange on output end assembly. Inspections will occur at the next scheduled inspection, service or maintenance action but no later than 30 days after receipt of this bulletin. Access to servoactuator on aircraft is possible with cowling removed.

D. Approval

Joseph Kempton, Woodward HRT Engineering

E. Manpower

With cowling already removed during scheduled helicopter service, inspection of shipset (three actuators) can be performed in less than 1 hour. With single actuator 41009852-101 or -102 Output End Assembly disassembled, rework operation can be performed in less than 1 hour.

F. Material Price and Availability

Based on empirical data, a low percentage of output ends will be affected. There will be no cost to customers for rework of output ends or replacement of output ends if exchanged through Woodward HRT (formerly HR Textron).

Prior to returning any servo to service center, contact Woodward HRT Customer Service at: 25200 West Rye Canyon Road, Santa Clarita, CA 91355-1265; 661-702-5509, or 661-702-5391 (tel. numbers), or 661-702-5970 (fax) attention Customer Services Manager Duane Winn. Provide Woodward HRT with the part number, serial number, time since new for new servo and in addition time since overhauled or repaired and the facility if the servo was recently overhauled or repaired.

G. Tooling Price and Availability

Standard 0.003-inch feeler gage is required.

H. Weight and Balance

Not affected.

I. Electrical Load Data

Not affected.

ALERT SERVICE BULLETIN

J. References

67-32-09 Component Maintenance Manual with Illustrated Parts List (for) Hydraulic Servo Actuator Assembly part number 41011300-103 (BHT 206-076-062-105 and -111).

K. Other Publications Affected

The intent of this service bulletin will be incorporated into the next revision of 67-32-09.

2. Accomplishment Instructions

A. Part I. One-time check. To be accomplished by Operator:

1. Gain access to the tail rotor servo actuators. Refer to the M407 or M427 Maintenance Manual.
2. Verify the hydraulic servo actuator serial number on the data tag.
3. If the hydraulic servo actuator has a serial number not affected by this bulletin, make appropriate entry in the helicopter and component records to show accomplishment of this bulletin and indicate findings.
4. If the hydraulic servo actuator has a serial number affected by this bulletin, proceed as follows.
5. Verify that spacers 41003289 (two locations) show no evidence of contact as shown on Figure 2.
6. If the spacer shows evidence of contact at one of the two locations and does not rotate freely or offers sufficient resistance so it cannot be rotated by fingers, remove the hydraulic servo and send to a HRT approved service facility for rework before further flight. If the condition described in this step is found but no excessive force or feedback is reported by the pilot, a onetime ferry flight to nearest maintenance facility is allowed. Make appropriate entry in the helicopter and component records to show accomplishment of this bulletin and indicate findings.
7. If the spacer shows evidence of contact but rotates freely at both locations, send the servo actuator to a HRT approved service facility within the next 600 flight hours or 6 months whichever comes first for accomplishment of Part II of this bulletin. Make appropriate entry in the helicopter and component records to show accomplishment of this bulletin and indicate findings.

ALERT SERVICE BULLETIN

8. If the spacer does not show evidence of contact, use a feeler gauge and verify the clearance between the output end assembly bolt flange and the upper bolt spacer 41003289 as shown on Figure 3.
 9. If the clearance is less than 0.003 inch, send the servo actuator to a HRT-approved service facility within the next 1200 flight hours or 12 months whichever comes first for accomplishment of Part II of this bulletin. Make appropriate entry in the helicopter and component records to show accomplishment of this bulletin and indicate findings.
- B. Part II. Output assembly rework. To be accomplished by HRT-approved service facility:
1. Whenever hydraulic servo actuator 41011300-103 or -101 (Bell Helicopter P/N 206-076-062-105 or -111) prior to serial number HR1117 and without the identification "MOD 67-02" located on the underside of the 41009852-102 or -101 Output End is received for overhaul or repair, rework 41009852-102 or -101 Output End to following instructions and Figure 4.
 2. Rework bolt flange height (2 places) to 1.400-1.425 dimension shown on Figure 4. Rework form may be a straight cut or a blended radius.
 3. Identify with identification "MOD 67-02" located on the underside of the 41009852-102 or -101 Output End as shown on Figure 4.
 4. Chem-film reworked and identification area in accordance with MIL-C-5541 Class 1A.

ALERT SERVICE BULLETIN

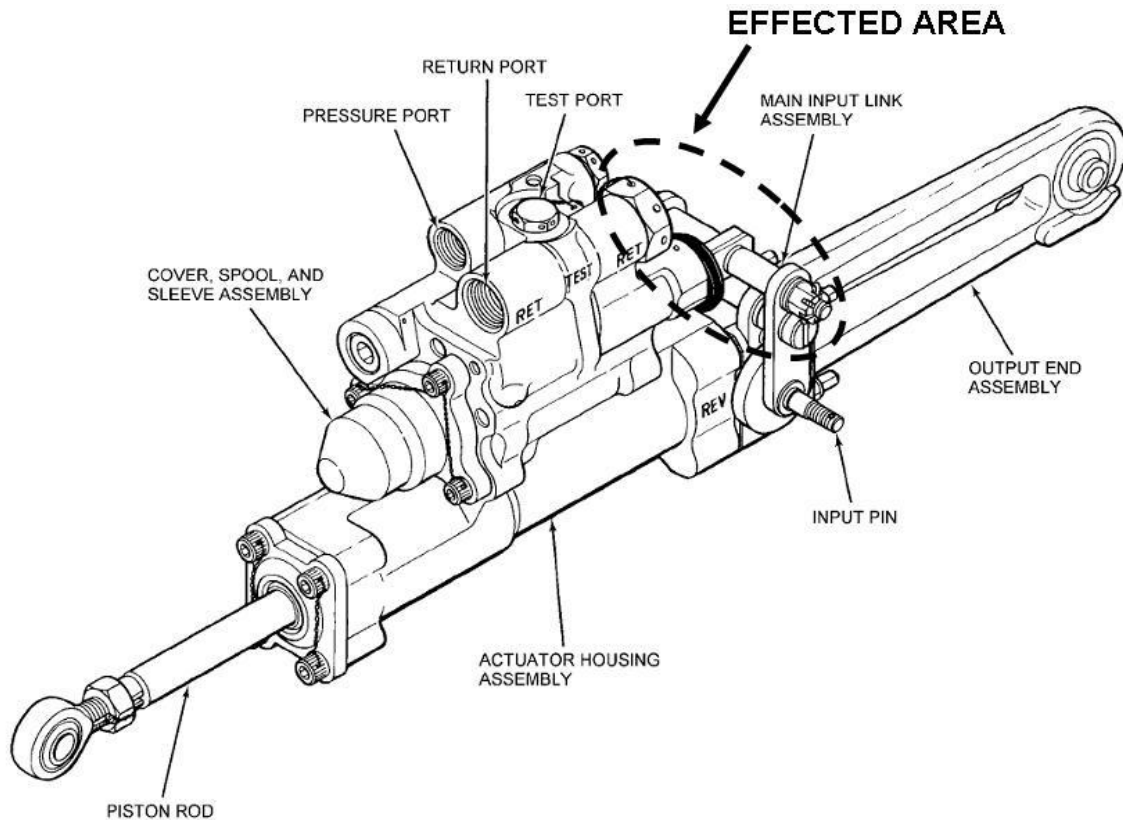

Hydraulic Servo Actuator P/N 41011300
Figure 1

ALERT SERVICE BULLETIN

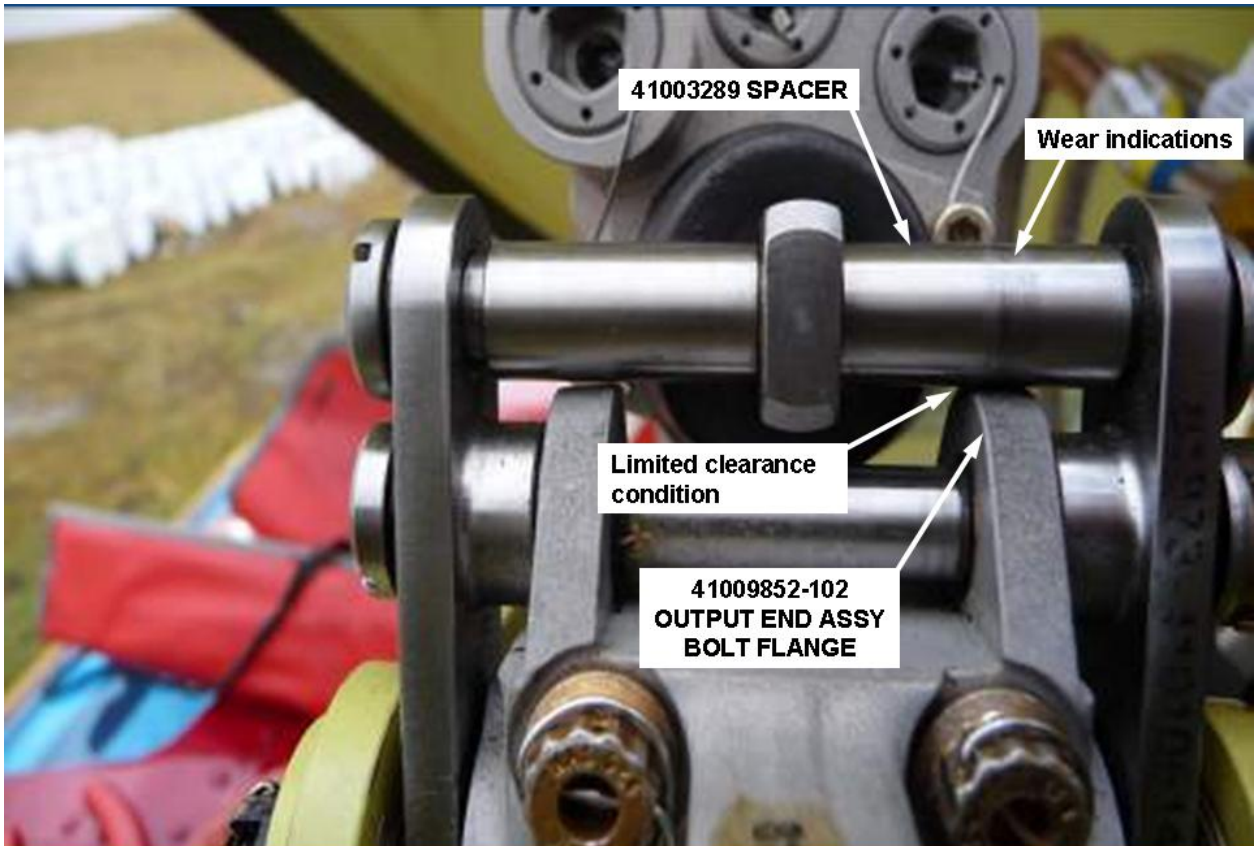

Wear Indications
Figure 2

ALERT SERVICE BULLETIN

WHRT PART: 41011300-103, -101
 BHT PART: 206-076-062-111, -105

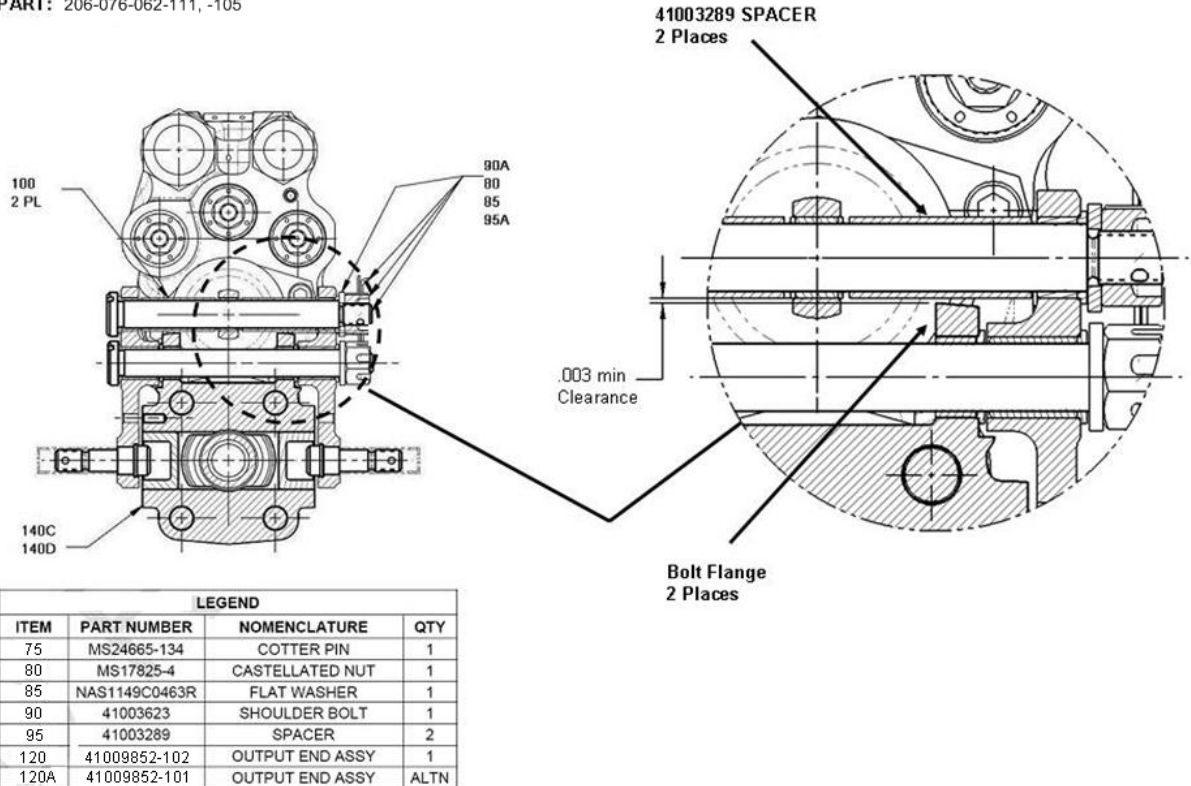

Clearance Data
 Figure 3

ALERT SERVICE BULLETIN

REWORK INSTRUCTIONS

IDENT WITH "MOD 67-02"
 .09 MIN HIGH CHARACTERS
 APPROX WHERE SHOWN.
 CHEM ETCH OR LASER ENGRAVE
 CHEM FILM REWORKED
 AREA IAW MIL-C-5541

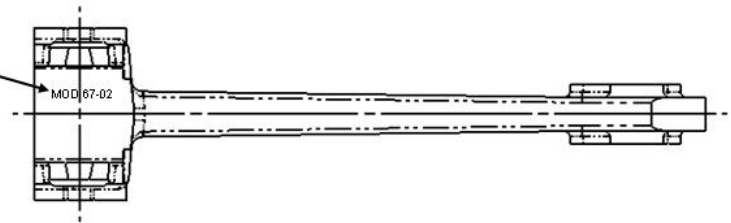

CHEM FILM
 REWORKED
 AREA IAW
 MIL-C-5541

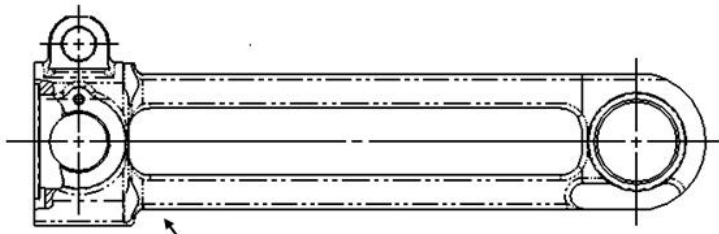
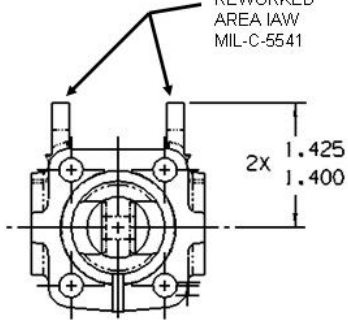

41009852-102 OUTPUT END ASSY
 MADE FROM 41009851-002 OUTPUT END
 41009852-101 OUTPUT END ASSY
 MADE FROM 41009851-001 OUTPUT END

Rework Instructions
 Figure 4