

September 22, 2000

INFORMATION LETTER 206L-00-71

TO: All Owners/Operators of Bell 206L-1, L-3 and L-4 Helicopters.

**SUBJECT: AFT ENGINE MOUNT LEGS 206-064-107-001, -003, -101, -103,
-109 and -111**

The purpose of this Information Letter is to notify all 206L-1, L-3 and L-4 operators that there is a dimensional difference in the length of the left and right aft engine mount legs.

Please ensure that when aft engine mount legs are installed that the appropriate length leg is placed on the appropriate side. Please refer to the attached Figure 1 to confirm length verses part number.

Refer to applicable Illustrated Parts Breakdown callout for engine mount leg part number effectivity.

INFORMATION LETTER 206L-00-71

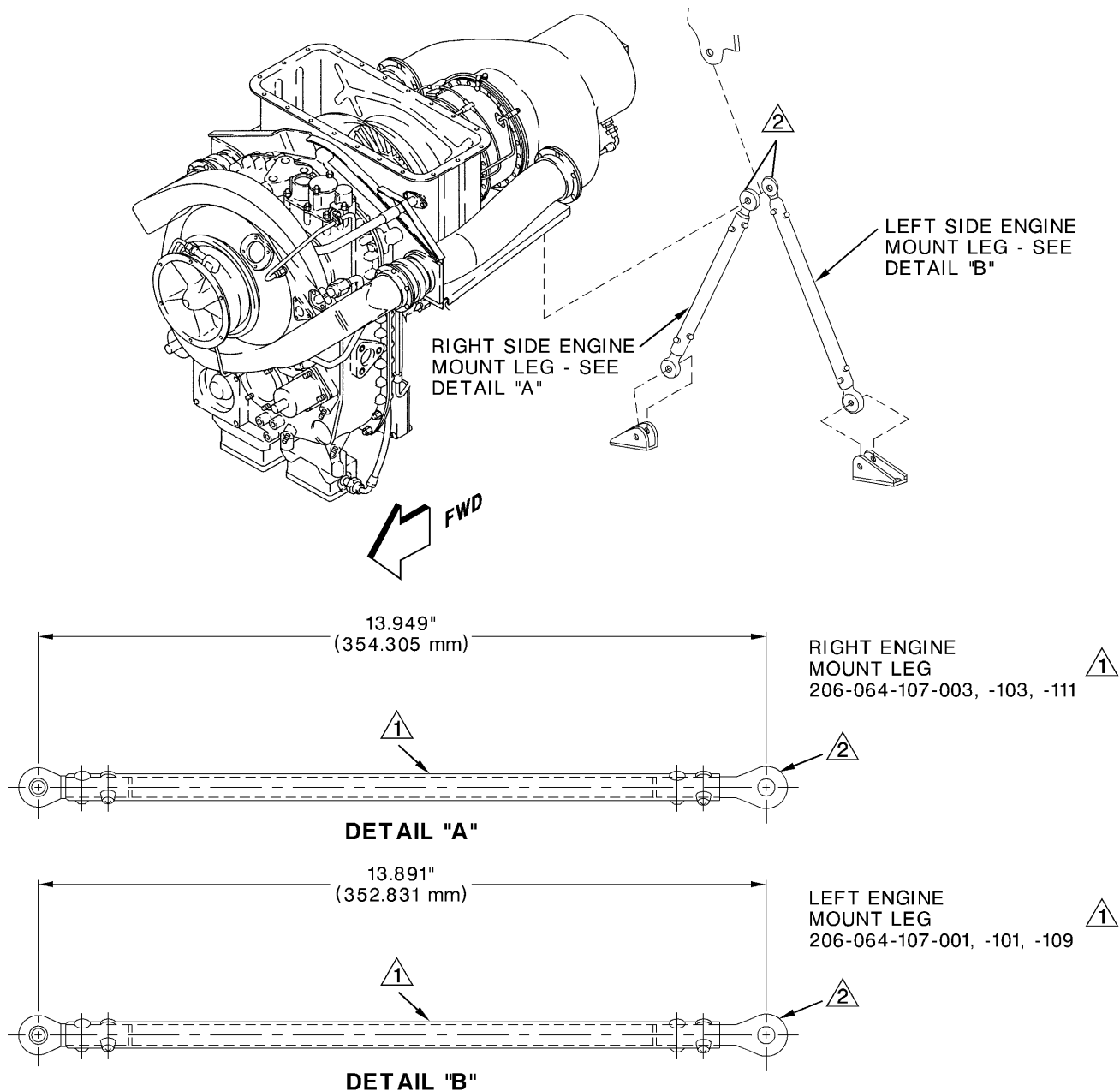

NOTES

- ① Part number ink stamped on leg. If no longer visible, identify by measurement shown in Detail A and B.
- ② For additional information 206-064-107-001, -003, -101 and -103 engine mount legs have lug thickness of .160" (4.06 mm). 206-064-107-109 and -111 engine mount legs have lug thickness of .200" (5.08 mm).

QIL00101

Figure 1