

# TECHNICAL BULLETIN

## Bell Helicopter **TEXTRON**

A Subsidiary of Textron Inc

No. 205-00-111

Date 05-19-00

Page 1 of 28

DATE
REV

**MODEL AFFECTED:** 205A-1

**SUBJECT:** FIN SPAR CAP 212-030-447-001/-101,  
REPLACEMENT OF.

**HELICOPTERS AFFECTED:** Model 205A-1 helicopters S/N 30229 through 30332 except helicopters which tailbooms have been retrofitted with P/N 212-030-447-117 spar cap.

**COMPLIANCE:** At customer's option

### DESCRIPTION:

Cracks have been found on the tailboom vertical fin left-hand spar caps in both the P/N 212-030-447-001 and -101 (hot bonded doubler) configurations. Fatigue cracks originated from the rivet holes in the area of the bonded doublers. Debonding of the doubler and corrosion contributed to the cracking of the spar cap.

This bulletin outlines the details of the procedure to replace the earlier-generation spar caps with a Cold Expansion spar cap P/N 212-030-447-117S. The installation of this spar cap has to be accomplished by personnel trained by Bell Helicopter. Contact Product Support Engineering for a list of facilities employing such personnel. This bulletin is not applicable to tailbooms already retrofitted with P/N 212-030-447-117, which can be identified by the presence of decals installed as per figure 7.

### APPROVAL:

The engineering design aspects of this bulletin are FAA/DER approved.

Incorporation of the provisions and instructions of this technical bulletin was approved by the Manager of the Rotorcraft Standards Staff, ASW-110, as terminating action to FAA AD 99-18-02.

### MANPOWER:

Approximately 150 man-hours are required to complete this bulletin. Man-hours are based on hands-on time, and may vary with personnel and facilities available.

**MATERIALS:**

**Required Material:**

The following material is required for the accomplishment of this bulletin and may be obtained through your Bell Helicopter Textron Supply Center.

<u>Part Number</u>	<u>Nomenclature</u>	<u>Quantity</u>
CA412-93-074-1	Fin Spar Cap Kit	1

**Note:** The Fin Spar Cap Kit consists of the following material:

<u>Part Number</u>	<u>Nomenclature</u>	<u>Quantity</u>
205-031-832-006P	Support, 42 deg. gearbox	1
212-030-447-117S	Spar Cap	1
212-030-446-001S	Support	1
212-030-099-157	Filler	1
212-030-099-159	Filler	1
209-031-863-001	Shim	2
31-080AD002026	Decal	2
31-023-13B	Decal	2
31-039-1A	Decal	2

-NOTE-

The following fastener listing covers an unmodified production assembly and oversize fasteners that may be required. Refer to ASB 205-86-23 Rev A and TB 205-86-67, if accomplished, to determine required fasteners. Other configurations may exist due to field repairs.

<u>Part Number</u>	<u>Nomenclature</u>	<u>Quantity</u>
100-048-5-5	Hi-Lok Pin	8
100-048-5-7	Hi-Lok Pin	8
100-048-5-8	Hi-Lok Pin	1
100-048-6-7	Hi-Lok Pin	8
100-048-6-8	Hi-Lok Pin	8
100-048-8-12	Hi-Lok Pin	2
100-048-8-14	Hi-Lok Pin	2
30-015-6	Collar	16
30-015-5	Collar	17
HL64PB-5-5	Hi-Lok Pin	8
HL64PB-5-7	Hi-Lok Pin	8
110-195-3C09	Rivet	8
HL64PB-6-7	Hi-Lok Pin	8

<u>Part Number</u>	<u>Nomenclature</u>	<u>Quantity</u>
HL64PB-6-8	Hi-Lok Pin	8
HL64PB-8-12	Hi-Lok Pin	2
HL64PB-8-14	Hi-Lok Pin	2
HL87-5	Collar	16
HL87-6	Collar	16
HL93-6	Collar	16
HL220PB-6-7	Hi-Lok Pin	8
HL220PB-6-8	Hi-Lok Pin	8
HL220PB-8-12	Hi-Lok Pin	2
HL220PB-8-14	Hi-Lok Pin	2
AN960JD416 <sup>1</sup>	Washer	4
MS21042L4	Nut	4
MS20470E6-13	Rivet	3
MS20470E6-12	Rivet	5
MS20470E6-11	Rivet	2
MS20470E6-10	Rivet	10
MS20470E5-10	Rivet	1
MS20470E5-9	Rivet	4
MS20470E5-8	Rivet	3
MS20470AD5-12	Rivet	1
MS20470AD5-11	Rivet	10
MS20470AD5-10	Rivet	16
MS20470AD5-9	Rivet	9
MS20470AD5-8	Rivet	8
MS20470AD5-7	Rivet	24
MS20470AD6-6-5	Rivet	1
MS20470AD4-9-5	Rivet	12
MS20470AD4-9	Rivet	11
MS20470AD4-8	Rivet	11
MS20470AD4-7	Rivet	10
MS20470AD4-6	Rivet	32
MS20426AD6-4	Rivet	1
MS20426AD4-10	Rivet	4
MS20426AD4-4	Rivet	17
MS20426AD3-8	Rivet	8
MS20426AD3-4	Rivet	40
M7885/6-5-09	Blind Rivet	4
M7885/6-5-08	Blind Rivet	12
M7885/6-5-05	Blind Rivet	52
M7885/6-5-04	Blind Rivet	33
M7885/6-5-03	Blind Rivet	33
M7885/6-4-04	Blind Rivet	14

<sup>1</sup> NAS1149D0463J washers are acceptable alternates to AN960JD416

<u>Part Number</u>	<u>Nomenclature</u>	<u>Quantity</u>
M7885/6-4-03	Blind Rivet	58
M7885/6-4-02	Blind Rivet	156
NAS9310M-5-03	Blind Rivet	10
NAS9310M-5-04	Blind Rivet	3

**Consumables:**

Order the following material in addition to kit CA412-93-074-1 (if required), however a shipping delay may be encountered depending on local hazardous material shipping regulations.

<u>Part Number</u>	<u>Nomenclature</u>	<u>Quantity</u>	<u>Reference</u>
MILS81733TY II-2 4OZ	Sealant	1	(C-392)
MILP23377ETYICL3 PT (513X395/910X710 or equivalent)	Primer	1	(C-204)
299-947-069	Clear Lacquer	1	(C-349)

-NOTE-

The following locally procured material will be required to fabricate spar cap drill template. Annealed aluminum is too soft to be acceptable material for drill templates.

2.0 X 2.0 X 90.0 inches 90 degree aluminum angle 0.125-inch stock  
4.0 X 0.190 x 90.0 inches aluminum stock  
0.050 in-thick strip of aluminum stock  
Machinist ink or suitable paint

**SPECIAL TOOLS:**

**CAUTION**

Only Cold Expansion tools and sleeves obtained from Bell Helicopter Textron or Fatigue Technologies Inc. are approved. Tools and sleeves procured from other sources have not been qualified to accomplish this bulletin.

FTI-BHTI412-1 Cold Expansion tool kit (Available on a rental basis from your normal Bell Helicopter Supply Center)

Tail Rotor Driveshaft Alignment Tools.

**WEIGHT AND BALANCE:**

<u>When replacing:</u>	<u>Weight change</u>	<u>Arm</u>	<u>Moment</u>
212-030-447-001	+0.3 lbs.	440.0 inches	+132 in-lbs.
212-030-447-101	No change		

**ELECTRICAL LOAD DATA:**

Not affected.

**REFERENCES:**

BHT 205A-1 Maintenance Manual  
BHT 205A-1 Illustrated Parts Catalog  
Alert Service Bulletin 205-86-23 Rev. "A"  
Alert Service Bulletin 205-93-56  
Technical Bulletin 205-86-67  
BHT-MED-SRM-1 Structural Repair Manual

**PUBLICATIONS AFFECTED:**

BHT 205A-1 Illustrated Parts Catalog

**ACCOMPLISHMENT INSTRUCTIONS:**

**CAUTION**

Spar cap replacement and Cold Expansion of fastener holes shall only be accomplished by personnel trained and qualified by Bell Helicopter Textron, Inc. No maintenance, rework or repair is allowed in the cold expansion area without prior approval of BHT Engineering.

1. Remove tailboom from helicopter and support with stand at forward end and strap cradle at Boom Station 185.
2. Remove drive shaft sections, bearing hangers, 42-degree gearbox, 90-degree gearbox, aft section and fin drive shaft covers, anti-torque control tubes in fin and center section of tailboom, control bellcrank support fitting on aft face of canted bulkhead and tail skid. Store for future use.

**-NOTE-**

Caution must be exercised to insure sheetmetal parts are not damaged during fastener removal. Use the following procedure. Refer to the Structural Repair Manual for approved alternate rivets.

- a. Note type, size, and location of all fasteners prior to removal.
- b. Drill off head of rivet.
- c. Punch out body. Back up thin parts to prevent deformation.
- d. Remove any burrs. Parts will be required for reassembly of fin-splice assembly. Any parts that are damaged must be replaced.

**-NOTE-**

As a precaution, a tailboom alignment may be performed prior to starting the spar cap replacement to establish a baseline. Refer to Chapter 66 of the Maintenance Manual. If the alignment cannot be performed satisfactorily, contact Product Support Engineering.

3. Remove clips P/N 212-030-099-091 and -093. See figure 2.
4. Remove support P/N 212-030-446-001 and associated fillers and shims. See figure 2, view A-A.
5. Remove rivets aft of tailboom station 175 that secure drive shaft cover angles P/N 205-031-862-043 and -077 to top surface of fin splice. See figure 2, view A-A.

**-NOTE-**

Deflect angles to provide access to rivets that attach 42-degree gearbox attach nutplates to supports and skins. Save nutplates.

6. Remove the (qty 8) MS20426AD3 rivets that attach the 42-degree gearbox attach nutplates to the supports and skins, if required. Referring to figure 2, remove doubler P/N 212-030-099-089/-129 and skin P/N 212-030-099-087/-131, by removing fasteners securing parts to tailboom. Slide skin and doubler assembly aft up along spar until clear of bulkhead and tailboom skin. Slide assembly forward, then slide parts from under angles P/N 205-031-862-043 and -077. Clean sealant from parts using plastic scraper, Scotch-Brite and Methyl-Ethyl-Ketone. Verify that skin and doubler assembly is still properly bonded. Refer to ASB 205-93-56.
7. Remove rivet attaching stiffener (tie angle) P/N 205-030-801-007 to left support P/N 205-031-832-004. Refer to figure 2, view A-A.

8. Identify area to be cold expanded with a grease pencil, or other suitable marker, from Fin Station 50 to Fin Station 84 on both the cap and the web. Record current fastener data in the cold expansion zone using the "MODEL 205 FIN SPAR COLD EXPANSION (Cx)<sup>2</sup> LOG." Refer to figure 4, attachment D and figure 8.
9. Remove fasteners securing left-hand spar cap. Remove cap from tailboom. Inspect the fastener holes in the web and the canted bulkhead. Note any holes that do not fall in the range of "final ream hole diameter" column in table 1. These holes must be opened to the next oversize. Record these holes in Model 205 Fin Spar Cold Expansion (Cx) Log.
10. Remove eight fasteners securing left 42-degree gearbox support, P/N 205-031-832-004, from left hand spar cap. This support will be replaced by new support P/N 205-031-832-006. Replacement of 42-degree gearbox support P/N 205-031-832-004 requires a locally fabricated template to transfer holes from the existing support to a new blank 42-degree gearbox support P/N 205-031-832-006P.

### CAUTION

All cold expanded holes must maintain a minimum edge distance of 1.5 after final ream as defined in table 1.

11. Inspect all existing holes in the removed cap for minimum edge distance of 1.5 (refer to attachment B and C). Any hole with low edge distance in the cold expansion area will be identified and not transferred to the template. It will be relocated in the cap to obtain a satisfactory edge distance. A small local repair can be done to the adjacent sheetmetal using instructions in chapter 3 of the "Structural Repair Manual". This inspection will also apply to any hole that will be oversized in later steps.
12. Fabricate spar cap drill template per figure 5.

### -NOTE-

Check the drill motor for wobble. Drill motor chuck wobble can contribute to oversized start hole.

- a. Attach a 0.125 x 2.0 x 2.0 inches aluminum angle x 90.0 inches long to a 0.190 x 4.0 x 90.0 inches aluminum strap with rivets to form a "T" shape. Attach a 0.050 inch spacer on template to correspond to the hinge location of the spar cap.
- b. Attach a 0.125-inch thick stop to strap with rivets (locator for lower end of spar).

<sup>2</sup> Cx is a registered trademark of Fatigue Technologies Inc.

- c. Spray template with machinist ink or any suitable coating to provide surface for marking template.
- d. Place bottom end of original spar cap on strap against stop with other leg against angle (refer to figure 5). Clamp in place. Make a note of the clamping sequence so that the same sequence may be used in later steps. Scribe a line around the spar cap on the template as a reference.

-NOTE-

Do not transfer holes at the bellcrank support attachment locations as nutplates will be replaced with Hi-Lok pins (refer to figure 4).

- e. Using a #10 drill for 3/16 fasteners, #20 drill for 5/32 fasteners and #30 drill for 1/8 fasteners, mark template to match spar cap.

-NOTE-

Extreme care must be used to ensure no side load or twist is applied to drill while marking and drilling template. All holes for "Hi-Loks" will be transferred through the template so as to keep the same angular alignment with mating fittings. The exception is the 90-degree gearbox support holes, which will be transferred from the actual support in the last steps of the cap installation. All other holes (rivet holes) will be marked on the template and then piloted using a drill block to insure a perpendicular hole.

- f. Using table 1, determine required tools to obtain desired Cold Expansion hole size. Pilot and open holes outside the Cold Expansion zone (Sta. 50 to 84) using drill blocks.

-NOTE-

It is preferable to keep the fastener holes to the minimum size after the cold expansion process. Therefore all holes in the cold expansion area will be transferred from the template undersized and opened with the Cx starting drill using a drill block. If oversize fasteners are to be installed, select appropriate tool for oversize fastener. Check the web and the canted bulkhead to help determine if an oversize fastener is needed.

- g. At location of "Hi-Lok" holes, transfer undersized holes through the template using a drill bushing with a #40 pilot drill. At location of solid rivets in the Cx areas, use the drill bushing supplied with the kit to transfer the correct Cx start-drill hole to the template.
- h. Remove old spar cap.

- i. In the cold expansion area of the template, drill pilot holes to correct start-drill size, and deburr holes in template.

### CAUTION

Clamp new spar cap P/N 212-030-447-117S in place in template with specific attention to protecting the new spar from mechanical damage.

### -NOTE-

After checking all edge distances, install spar cap in template in same position as original cap and clamp in place in same sequence (refer to step 12.d). The new spar cap must be in the same position as the original cap when drilling. Do not remove from template until all holes have been cold expanded.

13. Clamp new spar cap P/N 212-030-447-117S in place in template. Scribe a line around the new cap to compare to the line scribed from the old cap. This is used only as an indication of edge distance problem areas. The new cap should be marked with a pencil or marker prior to drilling to verify all edge distances.
14. In cold expansion zone of the new spar cap, pilot-drill Cx start-drill holes from template. Using drill block, open holes to Cx start-drill size. Do not use drill block on Hi-Lok holes except for holes common to new support P/N 205-031-832-006 (replacing -004 support). Do not open (qty 2) holes common to bellcrank support at this stage. Carry out Cold Expansion process on holes in specified area (refer to figure 6).

### -NOTE-

Any hole that does not meet requirements of step 7 of figure 6, attachment B and table 1 dimensions will be cause for rejection of entire spar cap. Therefore, it is advisable to complete the Cold Expansion process before other holes are drilled.

15. Outside the Cx zone, open holes to fastener size except holes common to the 90-degree gearbox support.
16. Relocate any low e/d holes identified per instructions at step 11 and holes for bellcrank support attachment.
  - a. Place new spar cap in fin and attach with clecos on full length.
  - b. Pilot-drill low e/d holes using the drill blocks and the start-drill from the appropriate kit.

- c. Locate holes for bellcrank support (refer to TB 205-86-67).
  - d. Remove spar cap from fin. Start ream and cold expand these holes as per figure 6.
  - e. Attach spar cap back into fin with clecos.
  - f. Finish ream holes (step 7 of figure 6). Remove spar cap and deburr all holes.
17. Touch up damaged paint areas and blend out damage on the spar cap that may have occurred during drilling, reaming and clamping operations. Attach spar cap back into fin with clecos.

**-NOTE-**

With proper tools, rivets can be reinstalled through lightening holes in spar web. If necessary to accomplish rivet installation in spar, blind rivets securing fin left skin to ribs may be removed as required to gain access to aft face of spar to buck rivets. Do not remove rivets common to or aft of the aft spar.

18. Install support P/N 205-031-832-006 to outboard side of spar cap P/N 212-030-447-117S. Finish ream support and spar cap together. Install "Hi-Loks" 100-048-6 pins (qty 8 required) and 30-015-6 collars. The heads of the Hi-Loks should be inboard to avoid interference when installing the fasteners on the web leg of the cap. Oversize fasteners may be installed, provided the correct Cx kit was used to expand the holes.

For example: A 100-048-5 pin is the current fastener but you want to install an HL64PB-6. The hole must be expanded with a 6-0-N kit for the HL64PB-6. Refer to table 1 for oversize fasteners and collars.

**-NOTE-**

If good holes are not obtained when reamed to 0.1625/0.1635, increase hole size with No. 17 drill and ream to 0.1885/0.1895. Use 100-048-6-( ) pin and 30-015-6 collar. See table 1.

19. Through holes in fin and 90 degree gearbox support fitting, ream Hi-Lok holes to 0.1625/0.1635 in new spar cap. Install 100-048-5-( ) Hi-Lok pin in each hole as reamed and secure with 30-015-5 collar.
20. Install MS20470AD5 rivets through leg against web and MS20470AD4 rivets through leg against skin (grip lengths as required) to attach spar from top end to canted bulkhead. Trim 212-030-121-023 stiffener, 212-030-136-017 filler, and 212-030-136-019 rib as necessary to fit with 212-030-447-117S spar cap.

21. Install remaining fasteners attaching the left forward vertical fin spar cap to spar web as shown in figure 4.
22. Remove nutplates from R/H spar cap at bellcrank support attachment locations and replace with Hi-Lok pins as per TB 205-86-67, if not previously accomplished.
23. Install 42-degree gearbox simulator (alignment tool) to attach and locate both supports. Locate rivet hole in support (tie angle) P/N 205-030-801-007 on left 42-degree gearbox support P/N 205-031-832-006. Clamp if necessary to maintain alignment. Drill for and install MS20470AD6 rivet in vertical flange. Remove 42-degree gearbox simulator.

-NOTE-

The use of MS20470AD rivets is recommended for the assembly of skins on fins and tailboom at locations where rivets can be bucked and rivet holes have not been enlarged.

24. Install doubler P/N 212-030-099-089/-129 and skin P/N 212-030-099-087/-131.
25. Reinstall nutplates on 42-degree gearbox supports (removed at step 6) using MS20426AD3 rivets. Countersink eight attaching rivet holes in top of support. When installing the nutplate rivets through the skin use 110-195-3C09 rivets with wet primer (C-204). Nutplates may be rotated 180° to provide edge distance on 205-031-832-006. Original nutplate fastener holes in the skin should be filled with sealant (C-392).
26. Prime any bare metal with primer (C-204).
27. Locate new support P/N 212-030-446-001S, fillers P/N 212-030-099-157 and 212-030-099-159 in place on skin and doubler and against face of spar as shown in figure 2, view A-A. Check edge distance on forward most holes in the 212-030-446-001S support (see figure 2, view A-A). If edge distance is less than 1.5, make a shim as shown in figure 3 and install it on top of filler 212-030-099-159. Transfer existing holes from structure. NAS9310M5 or M7885/8-5 fasteners (qty 10 required) may be used for the installation of the 212-030-446-001S support horizontal flange to the top of the tailboom skin and doubler. See figure 2, view A-A. Install fasteners with wet primer (C-204).
28. Install MS20470AD5 and MS20470AD4 rivets of proper grip length in all remaining locations where holes have not been enlarged and access for bucking is available. Skin and doubler will be attached using Cherry MAX or Bulbed Cherry LOCK rivets. Using figure 2 as a guide, verify such holes are as follows: all (-4) rivet holes are 0.143 to 0.146 inch diameter and all (-5) rivet holes are 0.176 to 0.180 inch diameter. Make sure that all parts are pulled together.

29. If side skin was opened to install rivets on spar, the following fasteners may be used. Secure skin in place with clecos prior to riveting.
  - M7885/6-4-2 for attaching skin to ribs and stiffeners.
  - MS20426AD3-4 rivets to secure nutplates around access door openings.
  - MS20426AD4-4 rivets between nutplates.
30. Apply a 1/8-inch bead of sealant (C-392) under edge of all unriveted skins. Lay a 1/8-inch bead of sealant along skin and around edge of clip-to-skin faying surface. Secure clips P/N 212-030-099-091 and -093 in place with clecos.
31. Install fasteners while sealant is wet (refer to figure 2).
32. Using alignment procedure in Maintenance Manual Chapter 66, determine thickness and install two P/N 209-031-863-001 shims at 42-degree gearbox attachment location.
33. Verify all sheetmetal joints for a bead of sealant (C-392) and touch up sealant as required. Prime modification area with primer (C-204) and paint to match helicopter.
34. Install decals as shown on figure 7. **"CAUTION COLD EXPANDED HOLES"** decals at Fin Station 50 shall be pointing down and at Fin Station 84, pointing up. A paint stencil may be used instead of the line decals as follows: paint a 1/8-inch red stripe over the spar and onto the web at Fin Station 50 and at Fin Station 84. The arrows should touch these red stripes. Coat decals with clear lacquer (C-349).
35. Install bellcrank support and torque nuts (75 - 95 inch-pounds). Install the remaining parts removed in step 2, following Maintenance Manual instructions.
36. Make an entry in helicopter historical records and engrave tailboom data plate indicating compliance with this technical bulletin.
37. Recheck torque (75 - 95 inch-pounds) on bellcrank attachment nuts after 50 hours of flight operations.

-NOTE-

For any repair in the "Cold Expansion" area, contact Bell Helicopter Textron, Inc. Product Support Engineering.

38. Return a copy of the "MODEL 205 FIN SPAR COLD EXPANSION (Cx) LOG" to Product Support Engineering and retain originals for future maintenance related to the cold expansion area. Return Fin Spar (Cx) Log to:

**Bell Helicopter Textron**  
**Attn: Product Support Engineering, Medium Helicopters**  
**12,800 rue De l'Avenir**  
**Mirabel (Quebec) Canada J7J 1R4**

**Fax: 450-433-0272      Tel: 450-437-6201**  
**e-mail: [psemedium@bellhelicopter.textron.com](mailto:psemedium@bellhelicopter.textron.com)**

**ATTACHMENT A**

**CLEANING PROCESS**

**1. REMOVAL OF PAINTS AND PRIMERS:**

**CAUTION**

\* "Paint strippers" are not to be used. Contamination of core, adhesive bond line or fiberglass skin and edging with 'paint stripper' will be cause for panel replacement. Trichloroethylene and vapor degreasers are not to be used to clean or strip any surface adjacent to a damaged area. Use only Methyl-Ethyl-Ketone (MEK) or acetone to remove paint from skins and edging or exposed adhesive bond lines.

\*\* Excessive applications of MEK or acetone can affect bonding agents. Strip these areas by wiping rather than soaking.

a. Conventional finishes (varnishes, alkyd enamels, zinc chromate primer, etc.):

1. Mask off area to be stripped.
2. Brush apply MEK.
3. Remove lifted paint with a stiff fiber bristle brush.
4. Final clean by wiping with clean cheesecloth moistened with MEK.

b. Acrylic finishes:

1. Mask off area to be stripped.
2. Remove paint by wiping with clean cheesecloth moistened with MEK.

c. Epoxy finish:

1. Mask off area to be stripped.
2. Remove paint using non-silicone abrasive paper grit no. 240 or finer.
3. Wipe with clean cheesecloth until all evidence of residue has been removed.

2. **PREPARATION OF PANEL BONDING SURFACES:**

-NOTE-

Remove "peel ply" from Prebond (composite) material and sand lightly prior to cleaning.

**CAUTION**

Use alcohol for bonding preparation of fiberglass areas. Do not use MEK.

- a. Clean foreign material from parts to be bonded with clean cheesecloth moistened with MEK.
- b. Thoroughly sand surfaces to be bonded or to which filler is to be applied with non-silicone no. 240 grit wet or dry sandpaper or abrasive paper to remove finish, primer and foreign material.
- c. Mask off sanded surface area to protect surrounding areas from cleaning solution.
- d. Wipe sanded area with clean cheesecloth moistened with MEK or alcohol as required. Change cheesecloth frequently until all evidence of residue is removed, and wipe dry with clean cheesecloth.
- e. Remove all tape from masked area.
- f. Protect surface from contamination until final bonding is accomplished, recommend use of clean wrapping paper.

**ATTACHMENT B**

EDGE DISTANCE REQUIRED TO MAINTAIN 1.5 D

MAXIMUM FINAL REAMED HOLE DIAMETER (INCHES)	MINIMUM REQUIRED "e" EDGE DISTANCE OF 1.5D
0.133	0.200
0.146	0.219
0.166	0.249
0.180	0.270
0.1895	0.284
0.2026	0.304
0.2182	0.327
0.2500	0.375
0.2657	0.399
0.2812	0.422

## ATTACHMENT C

### Edge Distance

Edge distance is measured from the center of the hole to the edge of the part. "d" is the finished hole diameter and "e" is the distance from the center of the fastener hole to the edge of the part. The ratio:

$$e/d$$

which is edge distance, must be greater than or equal to 1.5 on the new part to cold expand the hole. Attachment B shows minimum "e" for each of the fasteners in table 1 based on the final ream size.

Manufacturing tolerance can affect edge distance. A shorter leg on the new spar cap can cause a hole with good e/d on the old cap to have short e/d on the new cap, thus requiring relocation of this hole.

-NOTE-

Whenever possible, an e/d of 2.0 should be maintained.

**ATTACHMENT D**

**HOW TO FILL OUT THE 'MODEL 205 FIN SPAR COLD EXPANSION (Cx) LOG'**

1. Column 1, "Fastener Location", identifies all fasteners in the cold expansion area starting at Fin Sta. 50. The fasteners on the upright leg are numbered 1u to Xu (generally 33 fasteners). The fasteners on the web leg of the spar cap are numbered 1w to Xw (generally 40 fasteners). Refer to figure 8.
2. Column 2, "Current Fastener Identification", is to note the fasteners that were removed from the spar cap in the cold expansion area.
3. Column 3, "Reinstalled Fastener Identification", is to note the fasteners that are reinstalled at each location. This will determine the proper tool to be used for cold expansion. It will also show where oversize fasteners were installed for future reference.
4. Column 4, "Final e/d = 1.50 Min", in a check-off column. A check is placed in this column to indicate that the e/d has been checked against minimum. The actual e/d should be checked against the next oversize fastener for the 1.50 minimum. This will ensure that you have two chances to get the start ream hole right. If 1.5 e/d is not available at the next oversize fastener, this should be noted in the remarks giving the actual "e" that exists.
5. Column 5, "Cx Tool Identification", is to note the tool system used to expand the fastener hole. This tool system is obtained from table 1 using the reinstalled fastener information in column 3.
6. Column 6, "Start Ream Gage Check", is a check off column that indicates the start ream hole has been checked with the combination gage supplied in the kit and that it meets the size criteria (step 3 of figure 6).
7. Column 7, "Post Cx Gage Check", is a check off column that indicates the expanded hole has been checked with the combination gage supplied in the kit (step 6 of figure 6).
8. Column 8, "Remarks", is for any information that may be useful in the future. Such information would include edge distance "e", on holes that cannot be oversized, the largest fastener that may be installed before e/d is less than 1.5, or any other information the mechanic may feel is useful.



**TABLE 1: HOLE PREPARATION/TOOL SELECTION FOR COLD EXPANDED FASTENERS**

FASTENER IDENT.	NOM. FAST. DIA. (IN)	TOOL CODE	FASTENER DIA. (IN)		START DRILL HOLE SIZE	PRIOR TO CX STARTING REAMED HOLE DIA. (IN)		FINAL REAMED HOLE DIA. (IN)	
			MIN	MAX		MIN	MAX	MIN	MAX
(MS20470AD)	1/8	4-0-N	.124	.128	#38	.113	.115	.129	.133
M7885/6-4-05	9/64	4-1-N	.139	.143	#32	.128	.130	.143	.146
(MS20470AD)	5/32	4-2-N	.155	.159	#30	.144	.146	.161	.166
100-048-5 (1)	5/32	4-2-N	.1625	.1635	#30	.144	.146	.1625	.1635
M7885/6-5-05	11/64	4-3-N	.172	.176	#25	.160	.162	.176	.180
100-048-6 (1)	3/16	4-4-N	.1885	.1895	#20	.169	.171	.1885	.1895
MS20470E6	3/16	4-4-N	.186	.191	#20	.169	.171	.1885	.1895
HL64PB-6 (2) (OS)	13/64	6-0-N	.2016	.2026	#19	.177	.180	.2016	.2026
HL220PB-6 (3) (2nd OS)	7/32	6-1-N	.2172	.2182	#15	.192	.195	.2172	.2182
100-048-8	1/4	6-3-N	.2485	.2495	#4	.225	.228	.2480	.2500
HL64PB-8 (2) (OS)	17/64	8-0-N	.2641	.2651	7/32	.235	.238	.2636	.2657
HL220PB-8 (3) (2nd OS)	9/32	8-1-N	.2797	.2807	15/64	.251	.254	.2792	.2812

(1) USE 30-015-X COLLARS WITH 100-048-X PINS

(2) USE HL87-X COLLARS WITH HL64PB-X PINS

(3) USE HL93-X COLLARS WITH HL220PB-X PINS

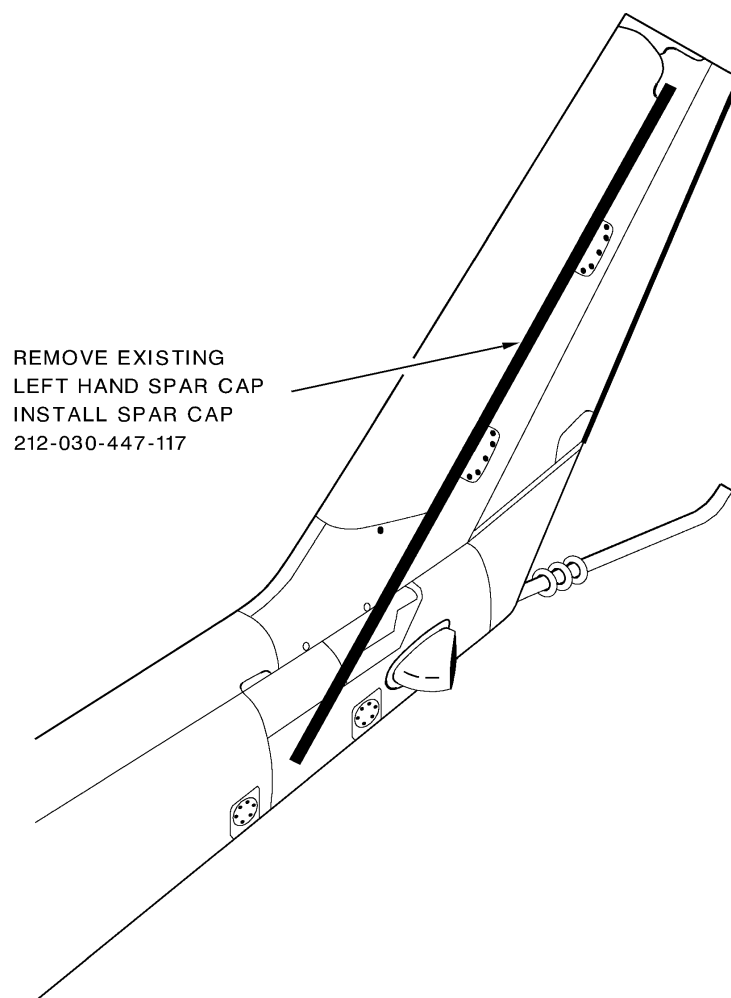

TTB00301

Figure 1

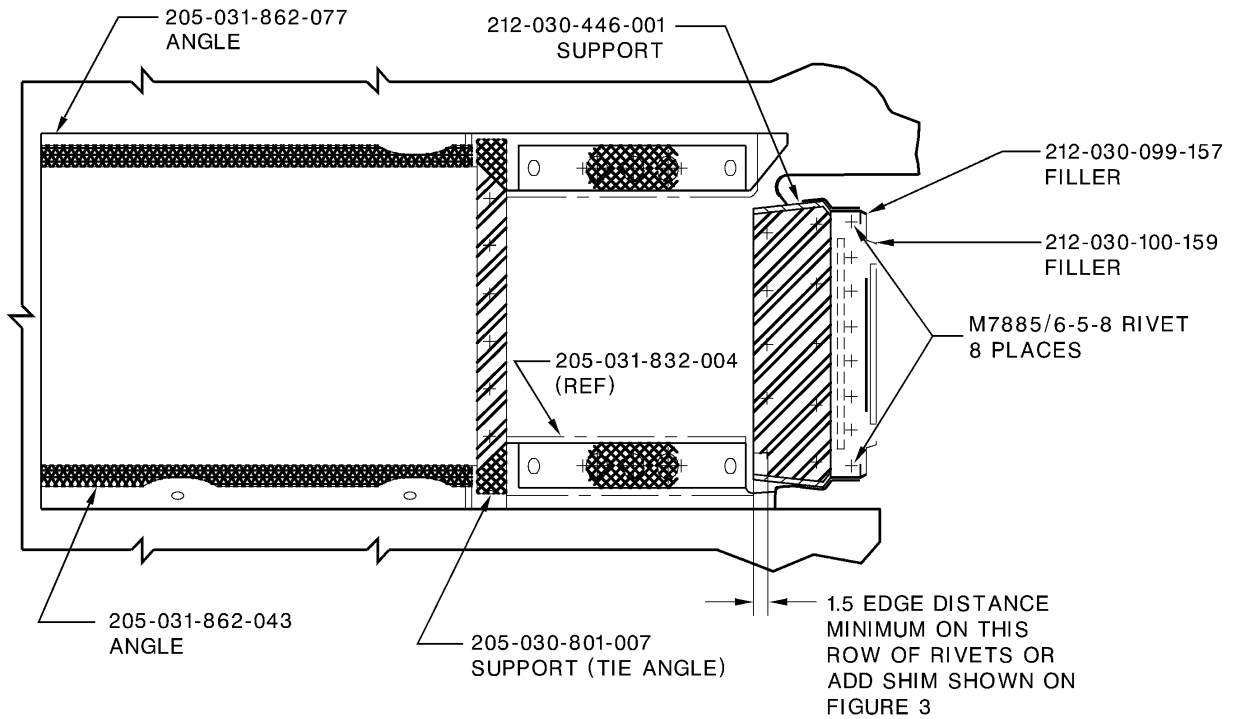

VIEW A-A

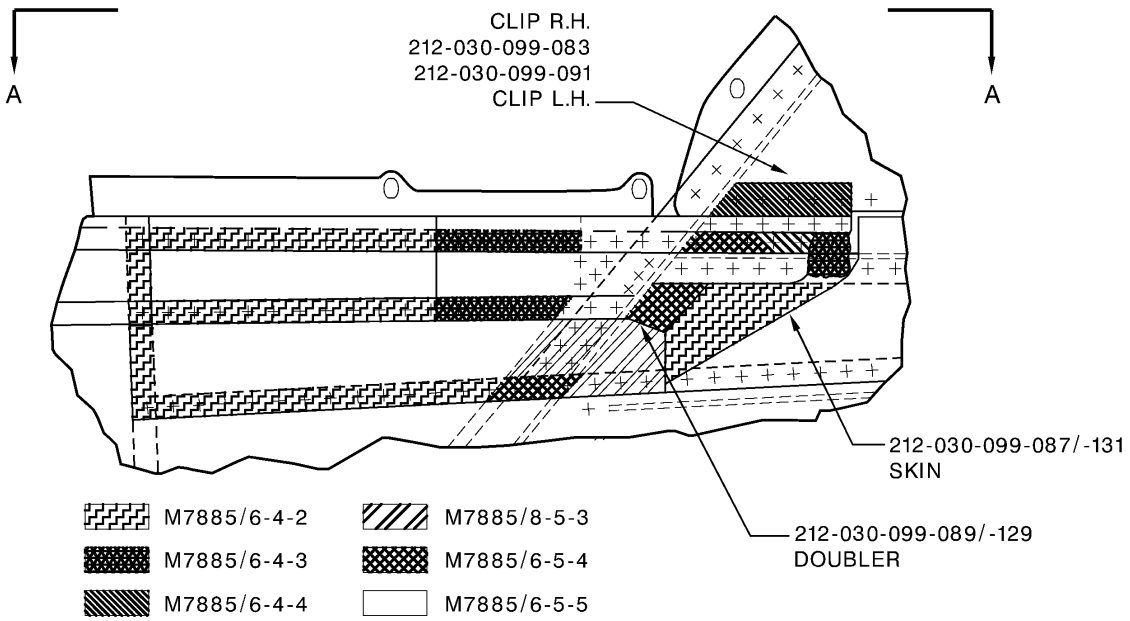

NOTES

Rivet count is only a reference.

TTB00302

Figure 2

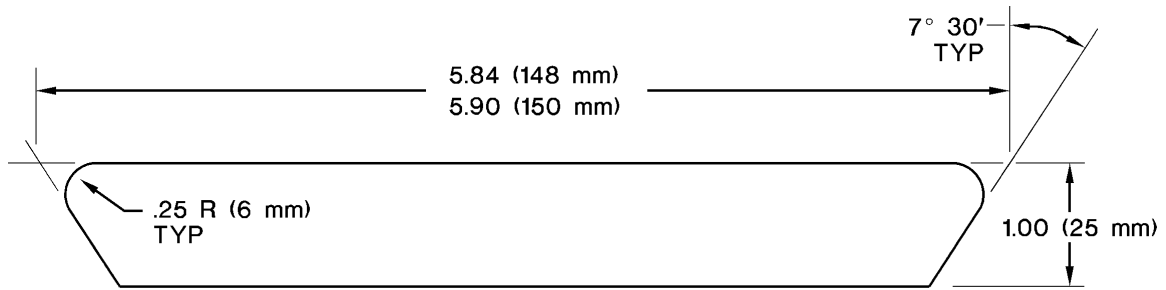

.032 TO .100 (0.8 TO 2.5 mm)  
2024T3 OR  
7075-T6 AL ALY

BREAK ALL EDGES .015 (0.4 mm) INSTALL ON  
TOP OF 212-030-099-157 FILLER

TTB00101

Figure 3

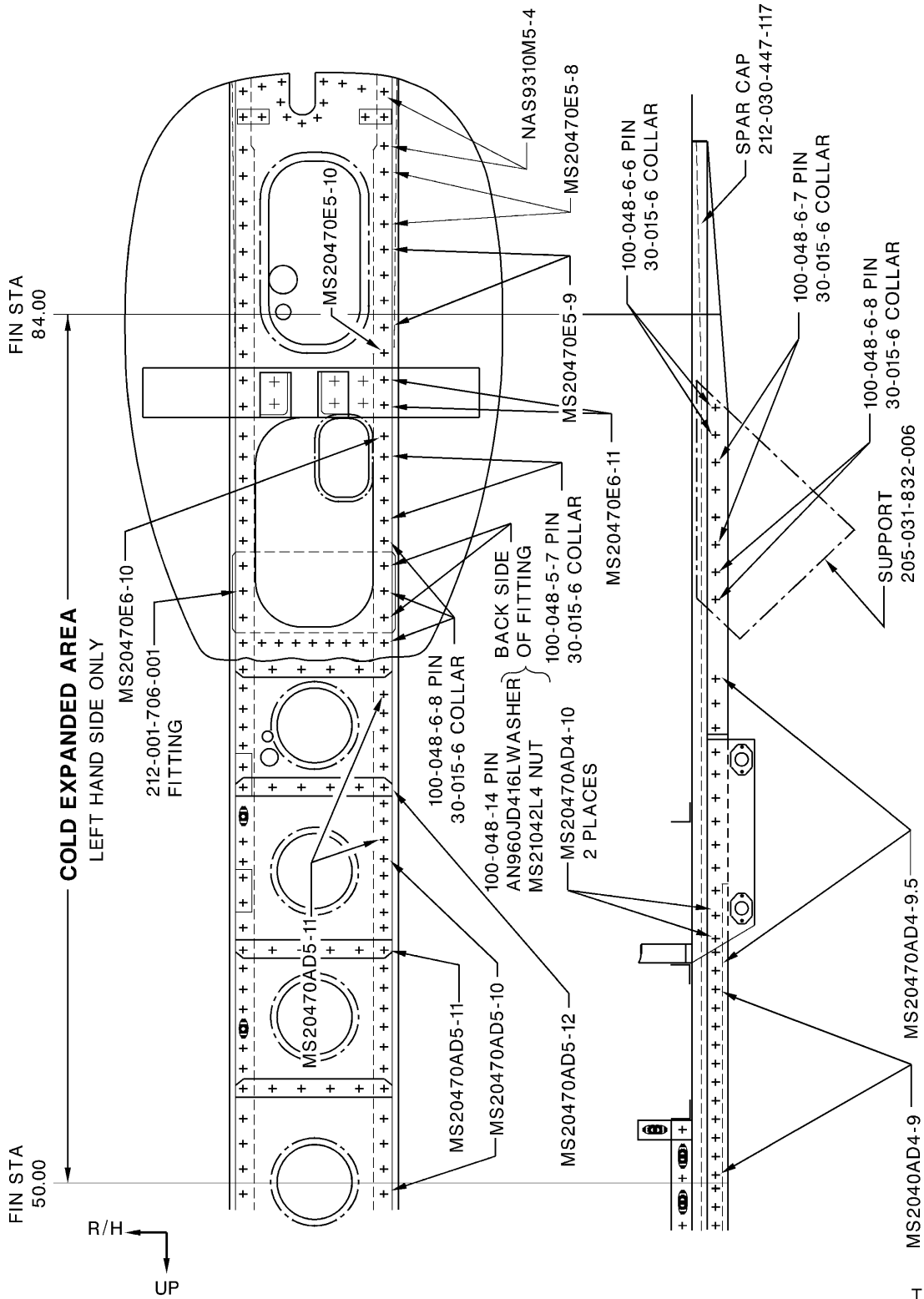

TTB00304

Figure 4

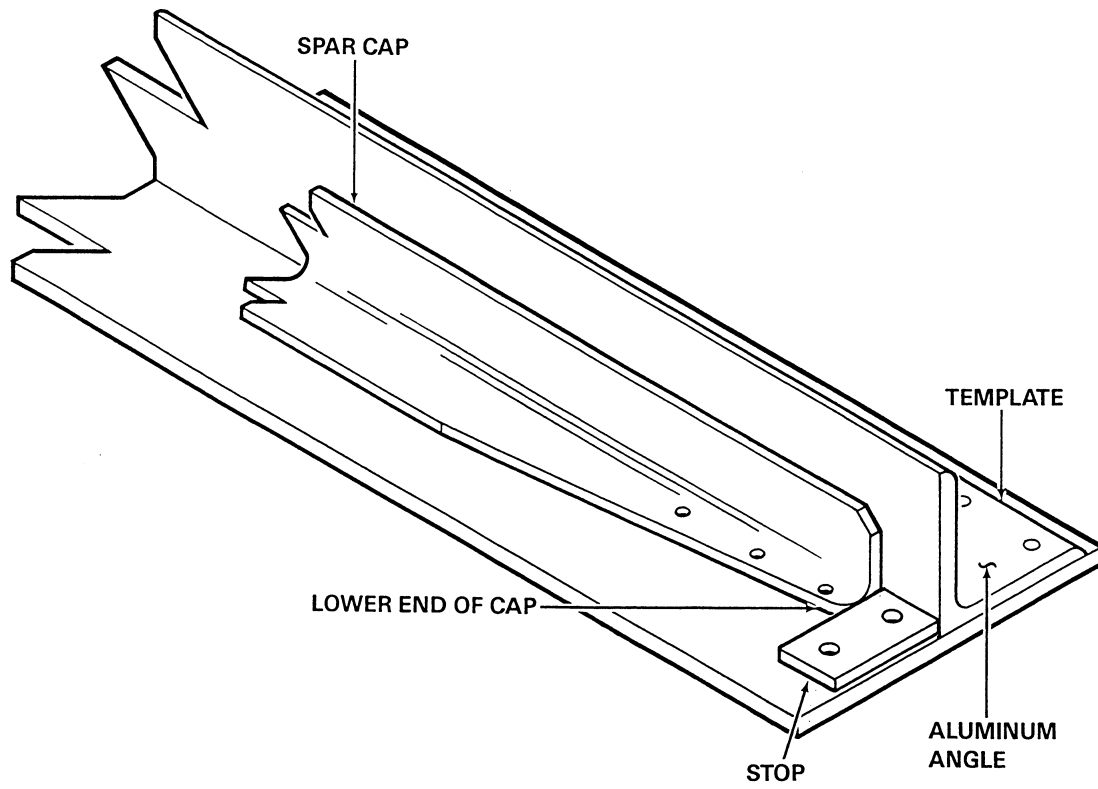
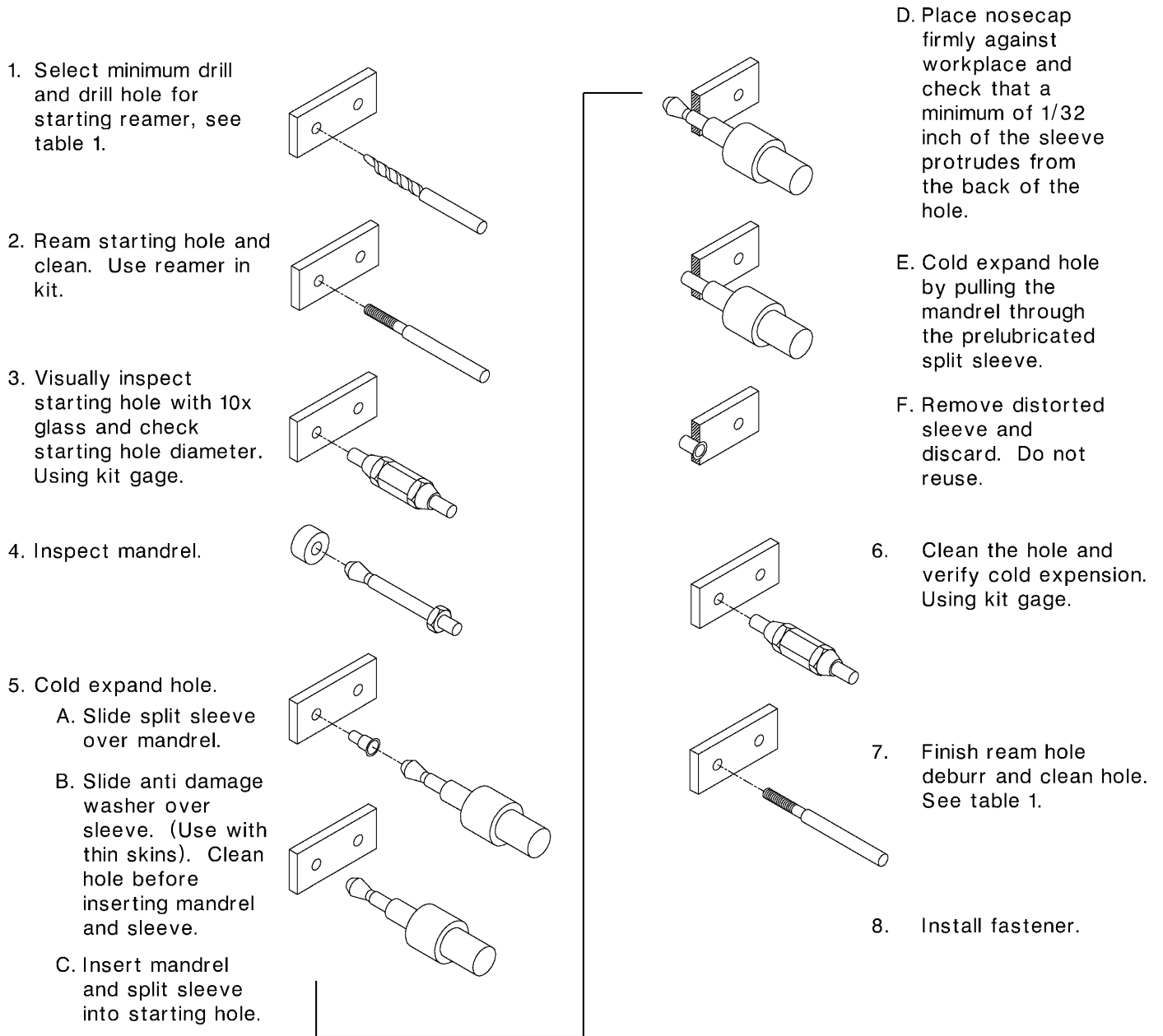
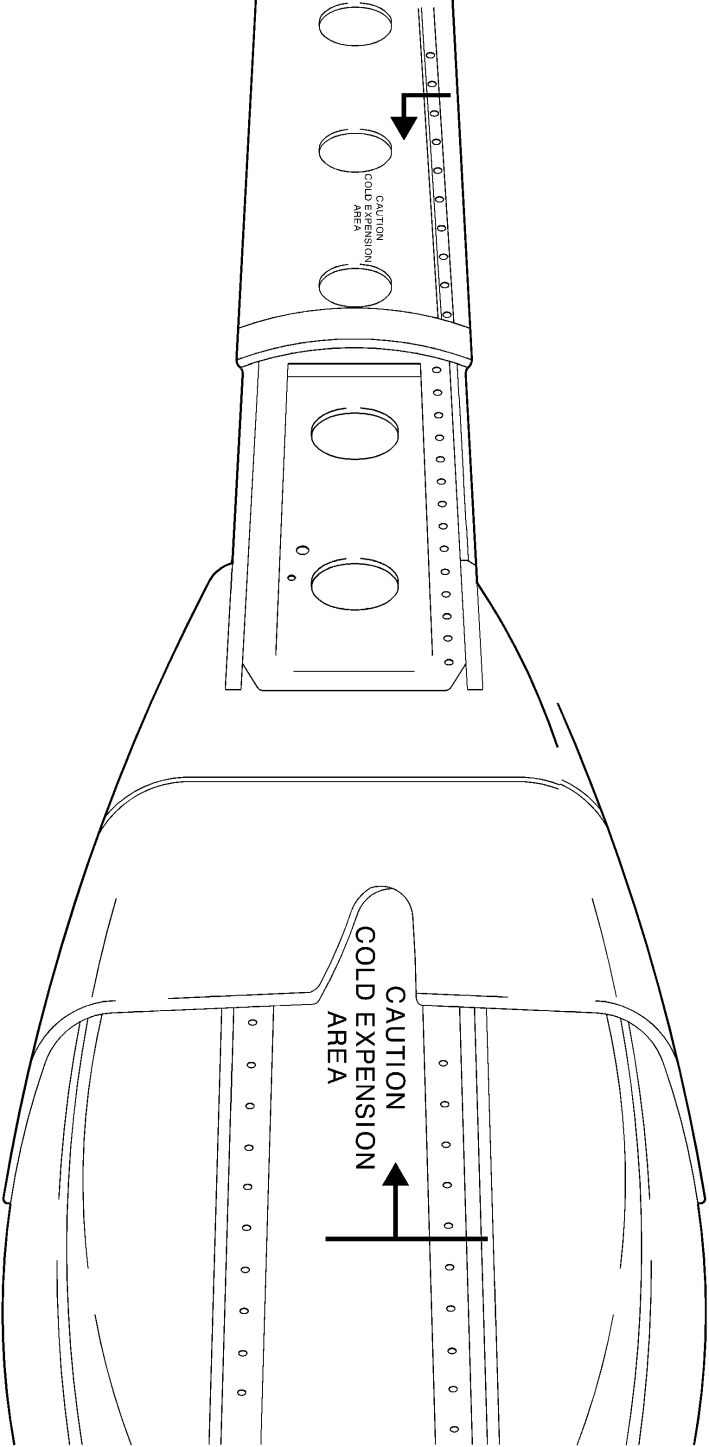

Figure 5

**PROCESS OVERVIEW**

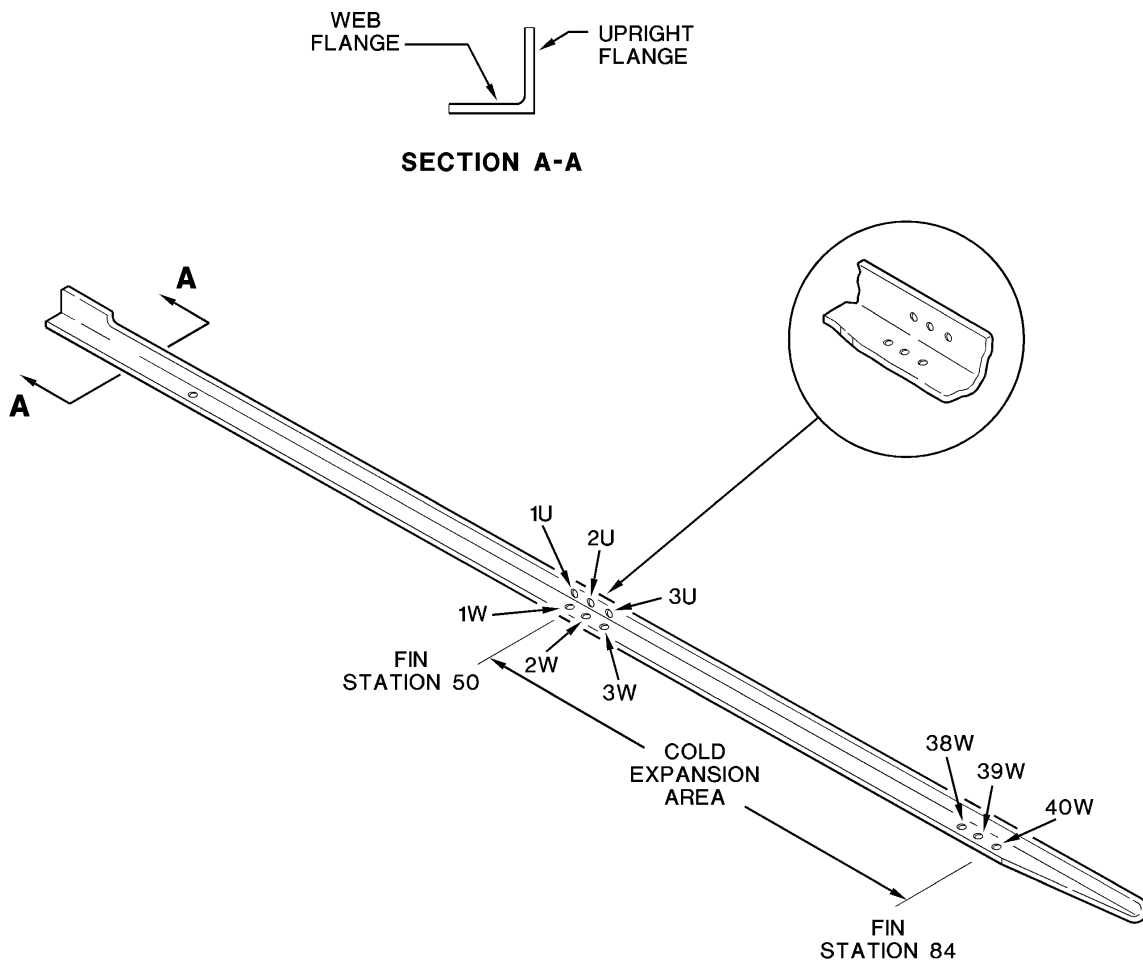

**Figure 6**



TTB00305

Figure 7



TTB00102

Figure 8