

TECHNICAL BULLETIN

Bell Helicopter **TEXTRON**

A Subsidiary of Textron Inc.

No. 205-99-112

Date 08/04/00

Page 1 of 5

DATE
REV

MODEL AFFECTED: 205A-1

SUBJECT: FORWARD CROSSTUBE, MODIFICATION OF

HELICOPTERS AFFECTED: Model 205A1 helicopters with standard (low) forward crosstubes P/N 205-050-400-005/-013/-037/-039/-055.

COMPLIANCE: At Customer's Option

DESCRIPTION:

This bulletin introduces modifications required to permit the use of the one-piece forged saddles with the original (P/N 205-050-400-005/-013/-037/-039/-055) style of forward crosstubes. The one-piece forged saddles require larger fasteners in the fore and aft crosstube attaching positions than the original two-piece sheet metal style.

APPROVAL:

The engineering design aspects of this bulletin are FAA/DER approved.

MANPOWER:

Approximately 4.0 man-hours are required to complete this bulletin. Man-hours are based on hands-on time, and may vary with personnel and facilities available.

MATERIAL:

Required Material:

The following material is required for the accomplishment of this bulletin and may be obtained through your Bell Helicopter Textron Supply Center.

<u>Part Number</u>	<u>Nomenclature</u>	<u>Quantity</u>
MS21069L6	Nutplate	4
MS20426AD3	Rivets	8
MS20426AD4	Rivets	8
90-019-1	Radius Block Assy	4

Consumable Material:

The following material is required to accomplish the bulletin, however, this material is considered consumable (bench stock) material and may not require ordering depending on the operator's consumable material stock levels. This material may be obtained through your Bell Helicopter Textron Supply Center.

<u>Part Number</u>	<u>Nomenclature</u>	<u>Quantity</u>	<u>Reference</u>
MILS81733TY II-2 4OZ	Sealant	1	C-392

SPECIAL TOOLS:

None required.

WEIGHT AND BALANCE:

Not affected.

ELECTRICAL LOAD DATA:

Not affected.

REFERENCES:

BHT-205A-1-Illustrated Parts Breakdown Manual, Chapter 32
BHT-205A-1-Maintenance Manual, Chapter 32
BHT-ALL-Standard Practices Manual

PUBLICATIONS AFFECTED:

BHT-205A-1- Illustrated Parts Breakdown Manual, Chapter 32
BHT-205A-1- Maintenance Manual, Chapter 32

ACCOMPLISHMENT INSTRUCTIONS:

1. Remove and disassemble landing gear from helicopter as per maintenance manual to accomplish the forward crosstube modification.
2. Remove the forward and aft radius block assemblies P/N 90-019-2 via drilling off attaching rivets on the forward crosstube (ref. Figure 1).

-NOTE-

At customer's option, the radius block assemblies can be replaced as an assembly. Simply order the required quantity of radius blocks assemblies P/N 90-019-1 and proceed to step number 7 (omitting steps 3 through 6).

3. Remove nutplates P/N MS21069L4 from the radius blocks assembly P/N 90-019-2.
4. Fill holes in radius block with P/N MS 20426AD3 rivets (double flush).
5. Enlarge the 0.264/0.270 inch holes in the 90-019-2 radius blocks to 0.403/0.410 inch.

-NOTE-

These rivets are wet installed using MILS81733TY II-2 4OZ sealant (ref. C-392).

6. Install new MS21069L6 nutplates with MS20426AD4 rivets in the previously reworked radius block. Radius blocks are now reworked to the 90-019-1 configuration.
7. Enlarge the two 0.265/0.272 inch diameter bolt holes in the fore and aft positions of the crosstube cuff to 0.385 / 0.392 inch.
8. Install 90-019-1 radius block assemblies in the fore and aft positions of the forward crosstube using P/N MS20426AD3 rivets.
9. Insure corresponding attachment holes in saddles are compatible and match. Re-assemble and install landing gear as per the maintenance manual.

10. Create a log card for the subject forward crosstube, re-identifying the original part number with the suffix "FM" for field modification. Indicate on the log card compliance with this technical bulletin.

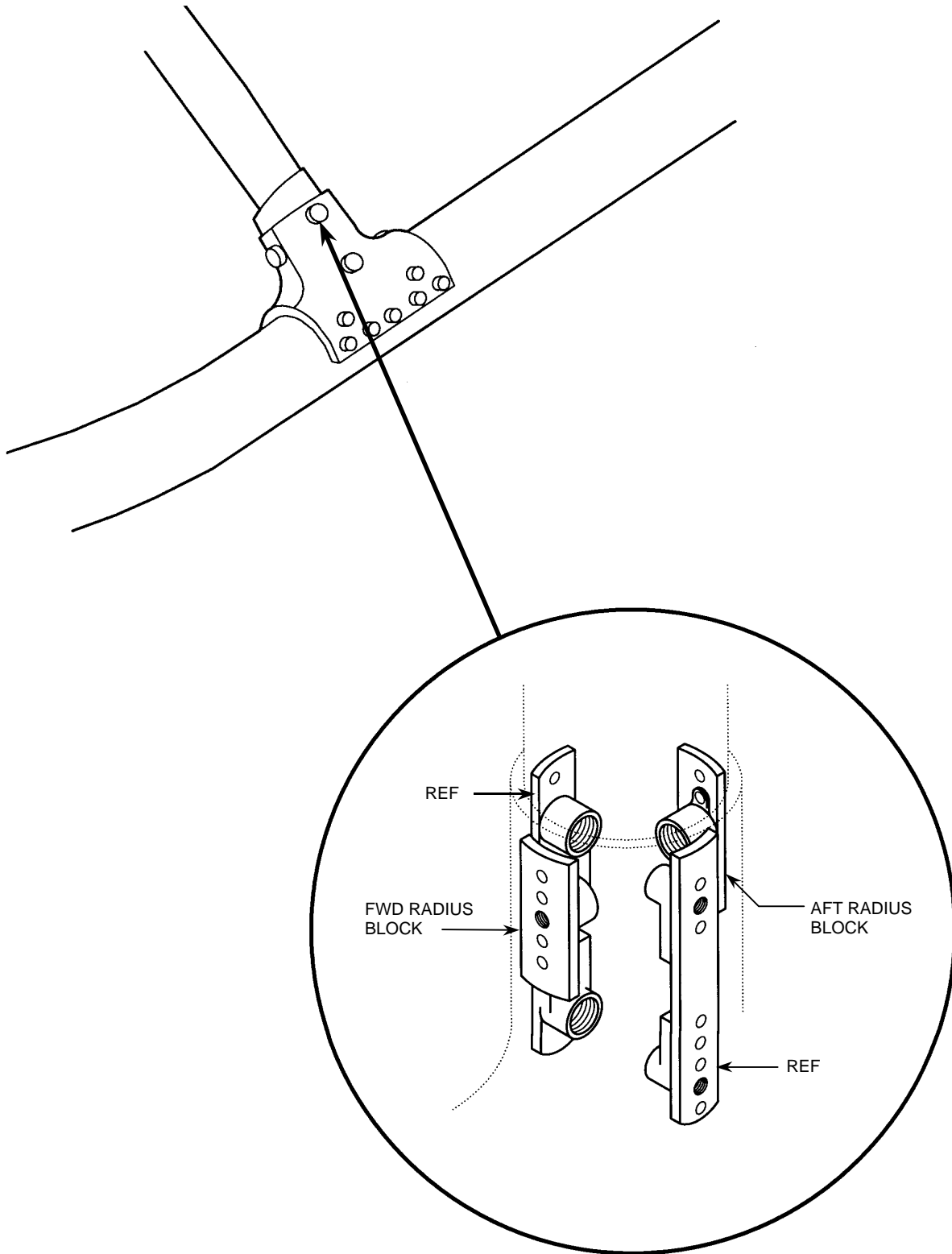

FORWARD CROSSTUBE RADIUS
BLOCK INSTALLATION

FIGURE 1