

TECHNICAL BULLETIN
Bell Helicopter **TEXTRON**

A Subsidiary of Textron Inc.

No. 205-04-115

Date 06-28-04

Page 1 of 5

DATE
REV

MODEL AFFECTED: 205A-1

SUBJECT: TRANSMISSION OIL PUMP 212-040-184-001,
MODIFICATION OF.

HELICOPTERS AFFECTED: All Model 205A-1 helicopters.

COMPLIANCE: At Customer's Option

DESCRIPTION:

Bell Helicopter has investigated some instances where mechanical damage was noticed on the oil pump shaft P/N 35-79501-0007-1 and key P/N 35-56017-0038-1.

This bulletin introduces a modification to the transmission oil pump P/N 212-040-184-001. The modification consists of an improved shaft, inner gerotor and cylindrical key. The part number of the modified pump is 212-040-184-101.

APPROVAL:

The engineering design aspects of this bulletin are FAA/DER approved.

MANPOWER:

Accomplishment of this bulletin during normal overhaul or maintenance will not require additional man-hours.

MATERIALS:

Required Material:

The following material is required for the accomplishment of this bulletin and may be obtained through your Bell Helicopter Textron Supply Center or Parker Hannifin Corporation-Customer Support Organization.

<u>Part Number</u>	<u>Nomenclature</u>	<u>Quantity</u>
32-00117-0044-1	Conversion Kit	1

The following parts are included in the Conversion Kit P/N 32-00117-0044-1.

<u>Part Number</u>	<u>Nomenclature</u>	<u>Quantity</u>
24-35200-2002-2	Gerotor assembly	1
35-56064-0566-1	Key, cylindrical spherical ends	1
35-79501-2246-3	Shaft	1
38-18312-0050-2	Retaining ring (alternate MS16632-3050)	2
MS16632-3050	Retaining ring (alternate 38-18312-0050-2)	
38-62010-1034-2	Nameplate, Blank	1

SPECIAL TOOLS:

None required.

WEIGHT AND BALANCE:

Not affected

ELECTRICAL LOAD DATA:

Not affected

REFERENCES:

BHT-205A1-IPB Illustrated Parts Breakdown
BHT-205A1-CR&O Component Repair and Overhaul

PUBLICATIONS AFFECTED:

BHT-205A1-IPB Illustrated Parts Breakdown, Chapter 66
BHT-205A1-CR&O Component Repair and Overhaul, Chapter 66

ACCOMPLISHMENT INSTRUCTIONS:

1. Disassemble pump in accordance with instructions given in BHT-205A1-CR&O, Chapter 66.
2. Discard retainers (4, Figure 1), gerotor assembly (5), key (6), and shaft (7).
3. Clean and inspect remaining pump components in accordance with instructions given in BHT-205A1-CR&O, Chapter 66.
4. Based on inspection results, replace all discrepant parts.

CAUTION

Parts discarded per Item 2 above are not interchangeable with new parts. Do not attempt to re-use any parts discarded per Item 2 in a 212-040-184-101 oil pump.

5. Refer to Table 1 for the configuration of the oil pump 212-040-184-001 or -101.
6. Re-assemble oil pump in accordance with instructions given in BHT-205A1-CR&O, Chapter 66.
7. Re-identify oil pump as follows:
 - a. With a vibrating stylus scribe part number 212-040-184-101FM and serial number on the new Nameplate (use the same serial number on the new Nameplate).
 - b. Remove and discard old Nameplate.

-NOTE-

The new Nameplate has an adhesive backing to attach it to the pump housing.

- c. Bond new Nameplate to pump body.
8. Make an entry in the helicopter records indicating compliance with this Technical Bulletin.

TABLE 1
TRANSMISSION OIL PUMP 212-040-184-XXX CONFIGURATIONS

<u>Qty</u>	<u>Part Number</u>	<u>Description</u>	<u>Configurations</u>		<u>Item</u>	<u>Note</u>
1	212-040-184	OIL PUMP	001	101	Fig. 1	
1	38-18313-0256-2	RETAINER	X	X	1	1
1	32-62320-0005-1	PLATE ASSY	X	X	2	
1	36-04503-0006-1	BEARING	X	X	3	
2	38-18312-0050-2	RETAINER	X	X	4	2
1	24-45200-2006-2	GEROTOR	X		5	
1	24-25200-2002-2	GEROTOR		X	5	
1	35-56017-0038-1	KEY	X		6	
1	35-56064-0566-1	KEY		X	6	
1	35-79501-0007-1	SHAFT	X		7	
1	35-79501-2246-3	SHAFT		X	7	
1	35-16003-0016-1	DOWEL	X	X	8	
2	38-18401-0003-1	SCREW	X	X	9	
1	32-54004-0031-1	HOUSING ASSY	X	X	10	
1	36-04503-0006-1	BEARING	X	X	11	
1	38-18311-0007-1	RETAINER	X	X	12	
1	38-18310-0007-1	INSERT	X	X	13	
1	38-62010-1034-2	NAMEPLATE	X	X	14	

Note

- 1 Retainer MS16631-3256 may be used as an alternate.
- 2 Replaced by MS16632-3050.

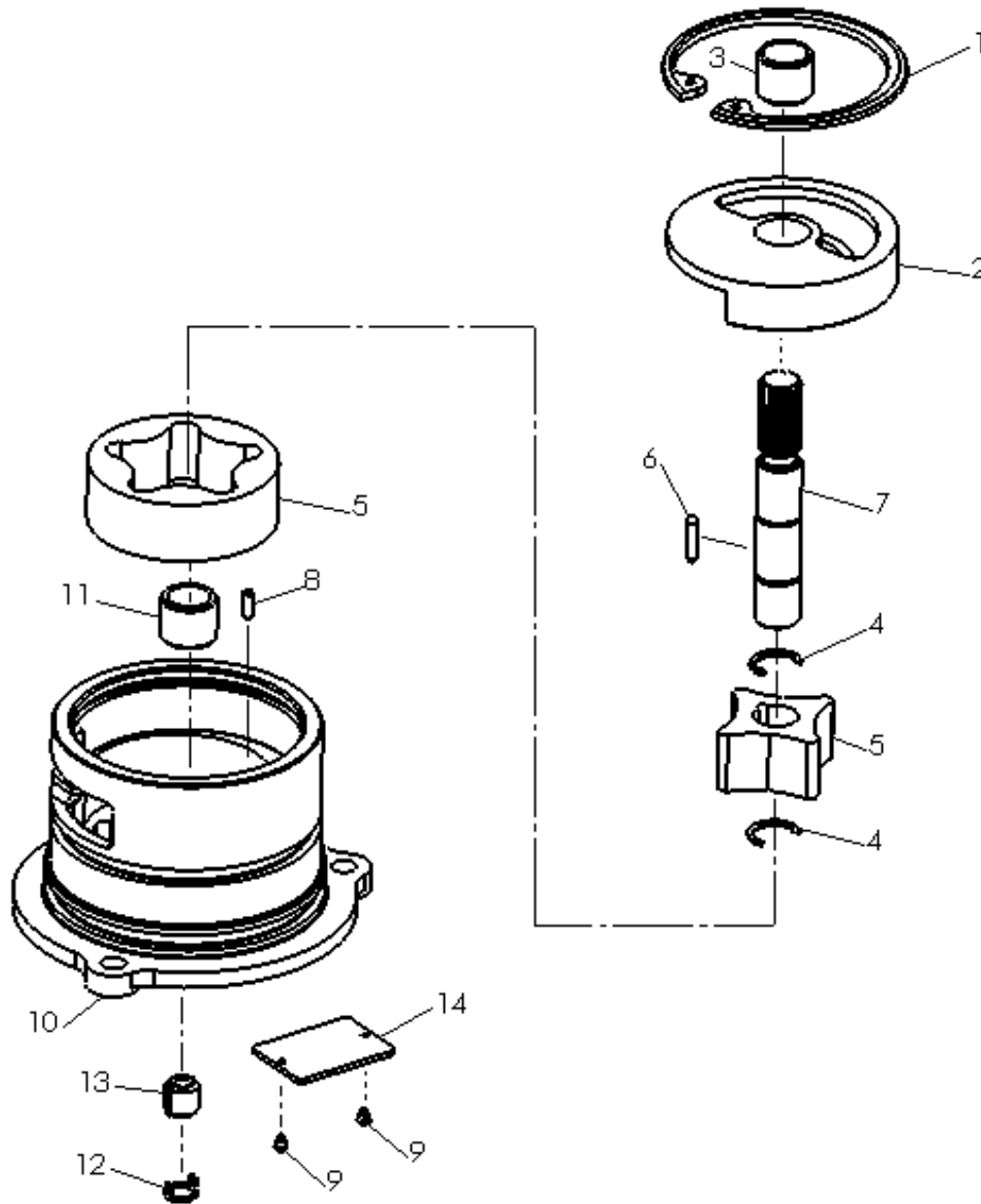

FIGURE 1

Transmission Oil Pump