

TECHNICAL BULLETIN
Bell Helicopter **TEXTRON**

A Subsidiary of Textron Inc.

No. 205B-03-21

Date 03-26-03

Page 1 of 11

DATE
REV

MODEL AFFECTED: 205B

SUBJECT: LOWER NOSE DOORS P/N 212-030-217-011 & 212-030-205-001 AND SEAL REPLACEMENT

HELICOPTERS AFFECTED: All Model 205B helicopters

COMPLIANCE: At customer's option but required upon replacement of the lower nose door assembly.

DESCRIPTION:

Bell Helicopter has introduced a new lower nose door assembly and a new seal arrangement for the upper and lower nose doors. The new lower door is a one-piece door made of composite that will replace both the P/N 212-030-217-011 and P/N 212-030-205-001. This bulletin provides the steps to install the new door and/or the new seal arrangement. The new seal installation (Part B) can be done independently or concurrent with the installation of the new door (Part A). However, if the new door is installed (Part A), the new seal must also be installed. The old door P/N 212-030-217-011 will only be stocked until depletion of existing inventory.

APPROVAL:

The engineering design aspects of this bulletin are FAA/DER approved.

MANPOWER:

Approximately 20 man-hours are required to complete this bulletin. Man-hours are based on hands-on time, and may vary with personnel and facilities available.

MATERIALS:

Required Material:

The following material is required for the accomplishment of this bulletin and may be obtained through your Bell Helicopter Textron Supply Center.

<u>Part Number</u>	<u>Nomenclature</u>	<u>Quantity</u>
412-030-061-101S	Panel Assy	1
412-030-078-117	Clip	1
412-030-078-118	Clip	1
212-030-217-023S	Clip	2
110-070-31	Seal	2 (ft)
110-070-41	Seal	3 (ft)
120-205-2	Seal	10 (ft)
SV4F-1	Stud	9
50-027-1	Retaining Ring	9
120-220-3P8	Screw	8
MS27039-1-08	Screw	2
MS27039-1-12	Screw	2
MS14142L3	Nut	2
50-017-1	Receptacle	11
MS20426AD4	Rivet	A/R
MS20426AD3	Rivet	A/R
MS20470AD4	Rivet	A/R

Consumable Material:

The following material is required to accomplish this bulletin, however this material is considered consumable (bench stock) material and may not require ordering depending on the operators consumable material stock levels. This material may be obtained through your Bell Helicopter Textron Supply Center.

<u>Part Number</u>	<u>Nomenclature</u>	<u>Quantity</u>	<u>Reference</u>
MILS8802CLB2 6OZ	Sealant	A/R	C-308
METHYL ETHYL KETONE	Methyl Ethyl Ketone	A/R	C-309
299-947-152TICL1	Adhesive (Dapcotac 3300)	A/R	C-300

SPECIAL TOOLS:

None required

WEIGHT AND BALANCE:

<u>Weight</u>	<u>Arm</u>	<u>Longitudinal Moment</u>	<u>Arm</u>	<u>Lateral* Moment</u>
-0.8 lbs	-14.7 in.	+ 12 in-lbs	0.0 in.	0 in-lbs
-0.4 kg	- 373 mm	+ 1.4 kg x mm/100	0.0 mm	0.0 kg x mm/100

* In lateral calculations, - is left and + is right.

ELECTRICAL LOAD DATA:

Not affected

REFERENCES:

BHT-212-IPC Illustrated Parts Breakdown

PUBLICATIONS AFFECTED:

BHT-212-IPC Illustrated Parts Breakdown

ACCOMPLISHMENT INSTRUCTIONS:

Part A: Installation of the composite lower nose door P/N 412-030-061-101

1. Make helicopter ready for maintenance.
2. Open lower nose door P/N 212-030-217-011 and remove from the aircraft.
3. Remove the aircraft battery, battery tray. Remove ballast weight P/N 212-030-173-ALL (if installed).
4. Remove glideslope antenna (if installed).
5. Remove all moving parts of the lower nose door hinges (Ref 212-030-217-005/007).
6. Remove fittings P/N 212-030-218-001 & -002 from each side of the door opening at WL 22 and plug holes with MS20470AD4 rivets of appropriate length.
7. Remove door assy P/N 212-030-205-001 below nose door.

8. Remove the two clips P/N 212-030-217-025 (WL 31.40). Retain receptacles for reinstallation.
9. Remove receptacles from two clips P/N 212-030-217-023 (WL 25.36) and retain for reinstallation.
10. Remove (qty 7) studs from panel P/N 212-030-206-ALL (ref Figure 1, Sheet 2, Section A-A). Retain hardware for reinstallation.

- Note -

During the following steps, remove and reinstall the new door as required to transfer the holes. Every time the door is reinstalled, as many fasteners as required should be attached to insure firm and repetitive location of the door.

11. Position the new door P/N 412-030-061-101 and trim only enough to allow preliminary installation. **Do not trim to final dimensions at this time.**
12. Transfer holes A & B from structure. Reinstall previously retained receptacles and applicable hardware (see Figure 1, Sheet 1).
13. Using a locally fabricated template made from a sheet of clear plastic (or equivalent method), transfer holes C to nose door and install applicable hardware (see Figure 1, Sheet 2, Section B-B).
14. Position new clips P/N 212-030-217-023 inside nose door at approximately 3.25 inches (true) down from holes A, picking up existing rivet locations on frames at RBL and LBL 14 with a minimum edge distance of twice the rivet diameter. (See Figure 1, Sheet 1) Drill two pilot holes with a #40 approximately 1 inch from the edge to locate the center of the receptacle holes.

- Note -

The following step requires conical washers (qty 2 on each side) to fill existing rivet countersunk holes. Upon removal of the existing rivets, the rivet shanks must be drilled-out to form a conical washer. These conical washers should be retained for reinstallation.

15. Install clips P/N 212-030-217-023 (see Figure 1, Sheet 3, View D), open holes D to final size and install applicable hardware.
16. Position clips P/N 412-030-078-117 and -118 to pick up the rivet holes left open by the previously removed clips at WL 31.4 with a minimum edge distance of

twice the rivet diameter. Install clips and open holes E to final size. Install previously retained receptacles and applicable hardware. (See Figure 1, Sheet 1)

17. Transfer holes F from panel (see Figure 1, Sheet 2, Section A-A) to the door assy. Open holes to final size and install applicable hardware.
18. Close upper nose door, transfer holes G, open holes to final dimension and install applicable hardware (see Figure 1, Sheet 2, Section C-C).
19. Once all fasteners are secured, mark for and trim the nose door to obtain a gap of 0.030 to 0.050-inch around the lower nose door. See Figure 1, Sheet 3, Section E-E.
20. Install the door seals P/N 110-070-31 & 41 along left and right sides of the door, using adhesive (C-300), as shown on Figure 2. Trim seals to clear clips (6 places), if required.
21. Refinish as required.
22. Accomplish Part B: Installation of new door seal.
23. Install ballast weight (if required), battery tray and battery.
24. Install glideslope antenna with MS27039-1-12 screws and existing washers, if applicable, applying a drop of sealant (C-308) under the screw heads. If no antenna is to be reinstalled, plug the holes with MS27039-1-08 screws, existing washers and MS14142L3 nuts, applying a drop of sealant (C-308) under the screw heads.
25. Install, close and latch nose doors, and verify for watertightness. Correct, if required.
26. Make helicopter ready for flight.
27. Make an entry in helicopter historical records indicating compliance with this technical bulletin.

Part B: Installation of new door seal

1. If not previously accomplished in part A above, prepare helicopter for maintenance, open upper and lower nose door, and remove from helicopter.
2. Using a plastic scraper, remove the seal from the nose structure around the periphery of the opening of the upper and lower nose doors.

3. Install seal P/N 120-205-2 on the nose structure around the upper and lower nose door opening using adhesive (C-300). Refer to Figure 1, Sheet 3.
4. Apply a light bead of sealant (C-308) around the nose door opening to seal the gap between the outer skin, the structure and the seal. Refer to Figure 1, Sheet 3. Allow sealant to cure for 24 hours.
5. Install upper nose door. Reinstall lower nose door (or refer to Part A, if replacing the door).
6. Close and latch nose doors, and verify for watertightness. Correct, if required.
7. Refinish as required.
8. Make helicopter ready for flight.
9. Make an entry in helicopter historical records indicating compliance with this technical bulletin.

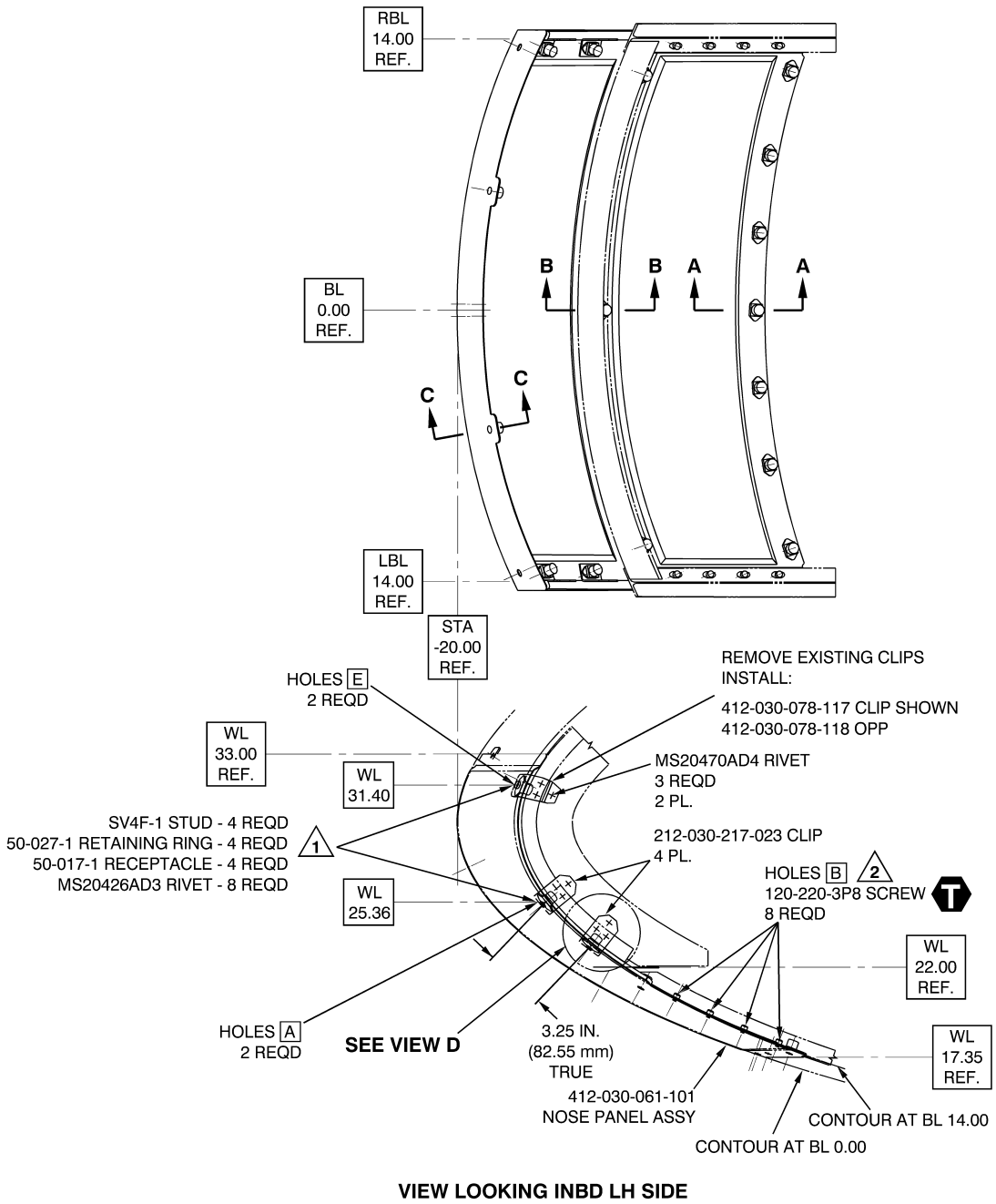
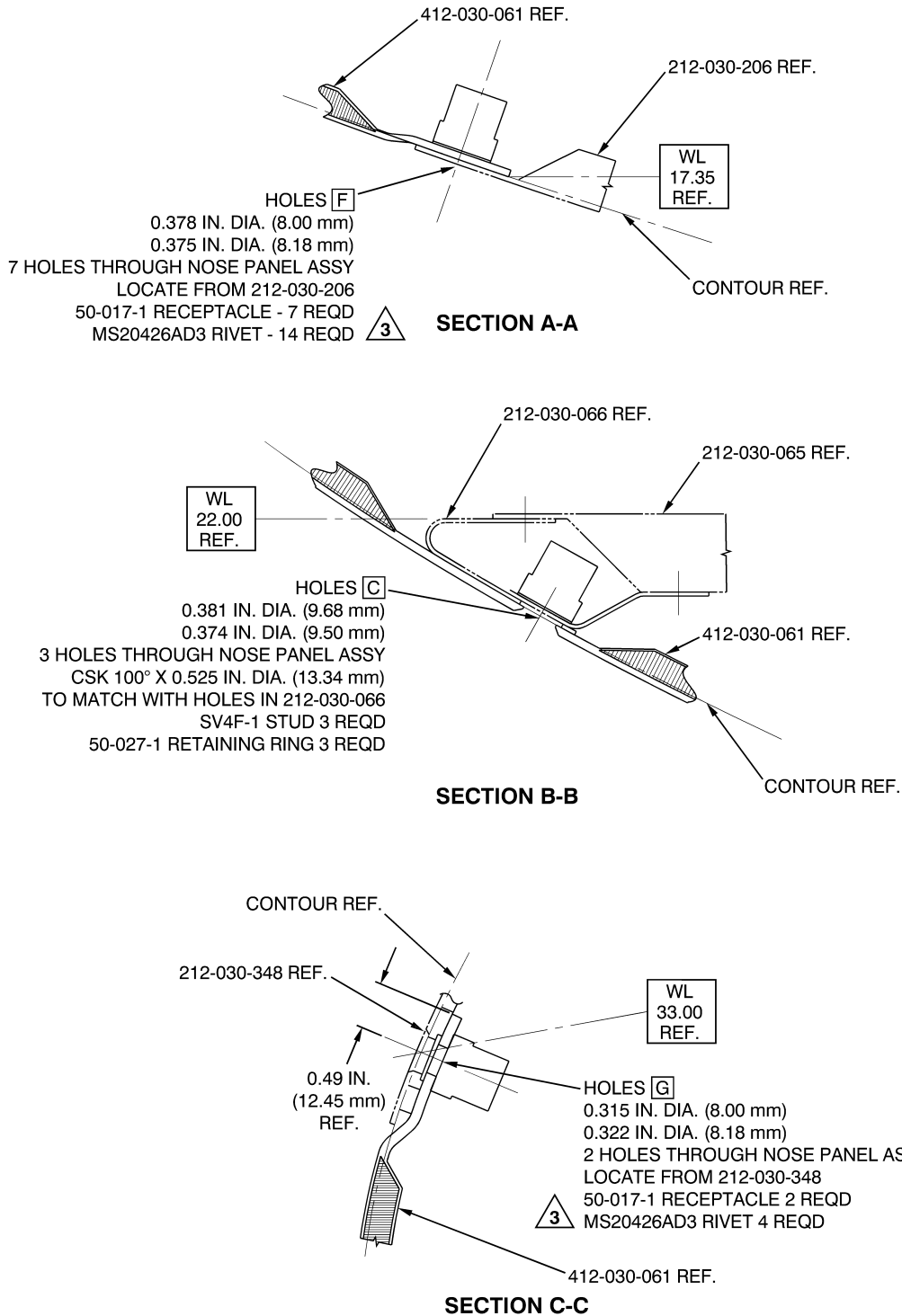

FIGURE 1 (SHEET 1 OF 4)
LOWER NOSE DOOR MODIFICATION

01549001



01549002

FIGURE 1 (SHEET 2 OF 4)
LOWER NOSE DOOR MODIFICATION

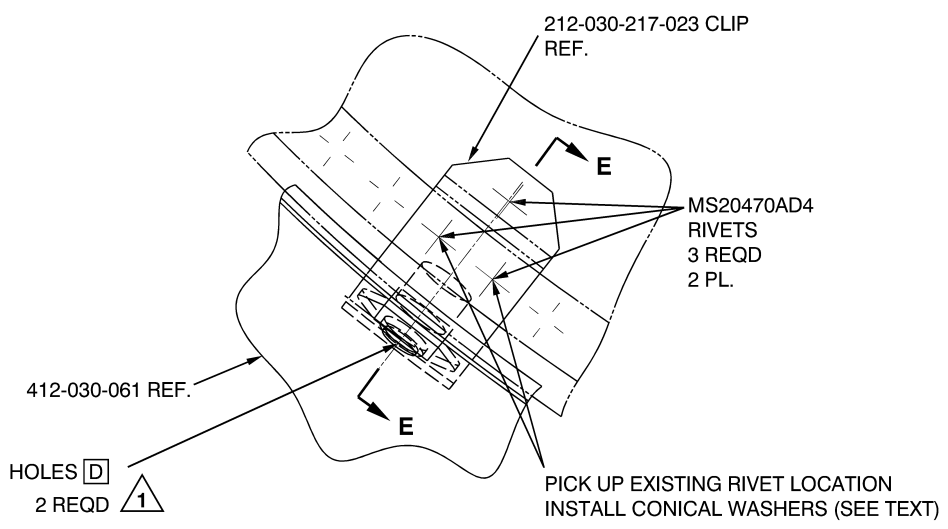

VIEW D

**VIEW LOOKING INBD
RH SIDE**

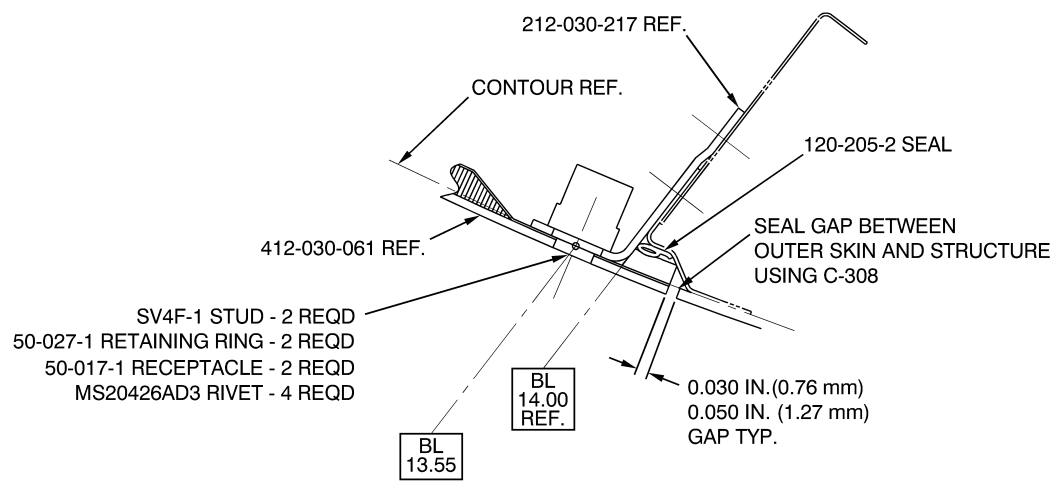



SECTION E-E

**FIGURE 1 (SHEET 3 OF 4)
LOWER NOSE DOOR MODIFICATION**

 TORQUE TO 30 TO 40 IN-LB
(3.4 TO 4.5 Nm)

NOTES

 0.381 inch (9.68 mm) diameter
0.374 inch (9.50 mm) diameter
CSK 100° X 0.525 inch (13.34 mm) diameter
through nose panel assembly
0.500 inch (12.70 mm) diameter
0.480 inch (12.19 mm) diameter
through clip

 0.214 inch (5.44 mm) diameter
0.208 inch (5.28 mm) diameter
through nose panel assembly
0.275 inch (6.98 mm) diameter
through seal

 Install rivets using a hand squeeze
to prevent possible cracking of fiberglass.

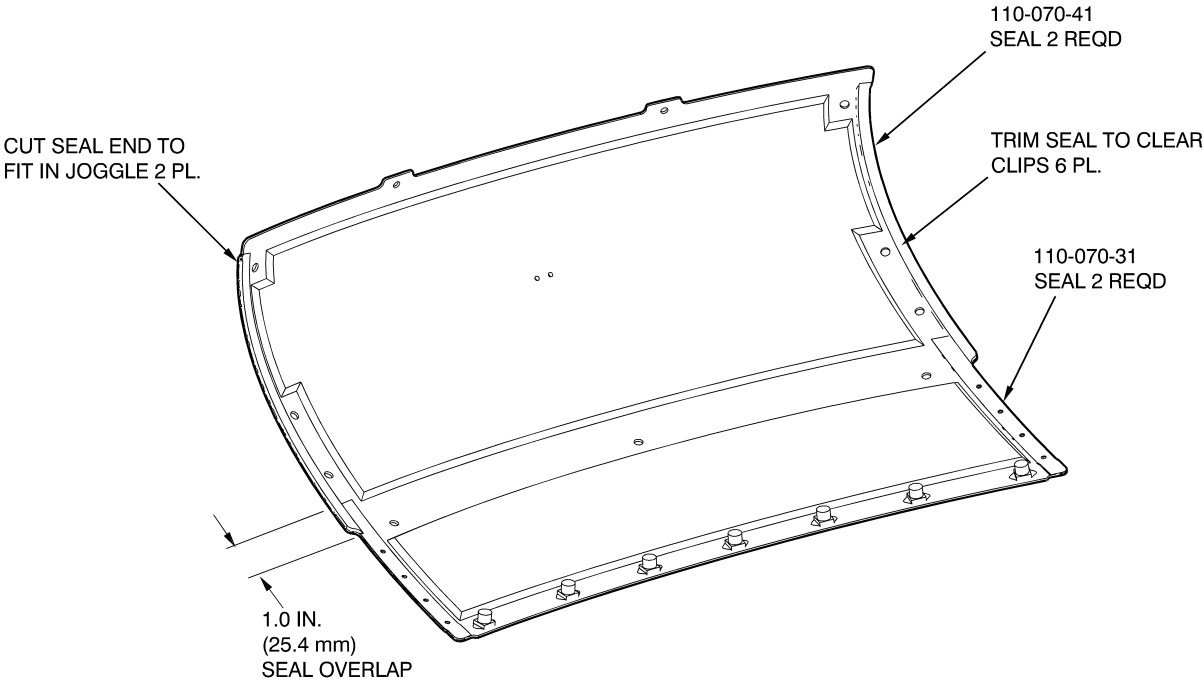

FIGURE 2
SEAL INSTALLATION