

TECHNICAL BULLETIN
Bell Helicopter **TEXTRON**
A Subsidiary of Textron Inc.

NO 206L-00-200

DATE 03-01-00

PAGE NO. 1 of 8

DATE
REV.

MODELS AFFECTED: 206L-4 Helicopters that have the High Altitude Kit installed.

SUBJECT: **HIGH ALTITUDE KIT TAIL ROTOR
BALANCING IMPROVEMENT, INTRO-
DUCTION OF.**

HELICOPTERS AFFECTED: 206L-4, Serial Numbers 52001 through 52202 and 52205 through 52214 with High Altitude Kit 206-704-722-101, /-103, /-109, and /-111 installed.

206L-4, Serial Numbers 52203, 52204, 52215 and subsequent with High Altitude Kit 206-704-722-113 will have the intent of this bulletin completed before delivery.

COMPLIANCE: At the option of the customer.

DESCRIPTION:

This bulletin introduces improvements to the subject kit by adding weight to the tail stinger. This addition will make it easier and less time consuming to balance the tail rotor.

APPROVAL:

The engineering design aspects of this Technical Bulletin are Transport Canada approved.

MANPOWER:

Approximately 1.0 man-hour is necessary to accomplish this Bulletin. Man-hours are based on hands-on time and may vary with personnel and facilities available.

MATERIALS REQUIRED:

The following material is necessary for the accomplishment of this Bulletin and can be obtained through your Bell Helicopter Textron Supply Center.

<u>PART NUMBER</u>	<u>NOMENCLATURE</u>	<u>QUANTITY</u>
407-030-845-115	Weight	1
407-030-845-117	Weight	2
MS21042L08	Nut	2
MS27039-0833, -0834, or -0836	Screw (NOTE 1)	2
NAS1149DN832J	Washer	4
31-053-18CFHP	Decal	1
NAS6604D20	Bolt	1
NAS1149D0432K	Washer	2
MS14145L4	Nut	1
MS24665-151	Cotter pin	1

NOTE 1: The length to be determined at installation.

CONSUMABLE MATERIAL:

<u>PART NUMBER</u>	<u>NOMENCLATURE</u>	<u>REF. NO.</u>
MILS81733TY II-2 4OZ	Sealant (NOTE 1)	C-392
MILS8802CLA2	Sealant	C-308
MILC85285TY1,11136	Paint (NOTE 2)	C-245
MILC85285TY1,17875	Paint (NOTE 3)	C-246
MILC85285TY1,CLEAR	Paint	C-245

NOTES:

1. The sealant is available as MIL-S-81733 TY II-1/2 and MIL-S-81733 TY II-2. The TY II-1/2 and TY II-2 identify the time limit in which you have to use the sealant. After you mix the sealant compounds, you must use the TY II-1/2 sealant in less than 30 minutes, and the TY II-2, in less than 2 hours. These two sealants are permitted.
2. Gloss Red, per Fed. STD 595.
3. Gloss White, per Fed. STD 595.

- NOTE -

The "C" REFERENCE Numbers above are in a cross-reference to the consumable list found in the Standard Practice Manual.

SPECIAL TOOLS:

None required.

WEIGHT AND BALANCE:

Installation of Part I will have the effects that follow on Weight and Balance:

<u>Longitudinal Weight Change</u>	<u>Arm</u>	<u>Moment</u>
+ 2.1 LBS. (+ 8.4 N)	+ 405.0 In. (+ 10287 mm)	850.5 IN-LBS. (86.41 Nm)

<u>Lateral Weight Change</u>	<u>Arm</u>	<u>Moment</u>

Not affected.

ELECTRICAL LOAD DATA:

Not affected.

REFERENCES:

BHT-206-SI-2054, Rev. 1, 21 August 1996

BHT-206-SI-2057, 12 July 1996

BHT-ALL-SPM, Reissue, 11 October 1996

Chapter 4, Painting

Chapter 13, Consumable Material



PUBLICATIONS AFFECTED:

BHT-206 SI-2054, Rev. 1, 21 August 1996

BHT-206-SI-2057, 12 July 1996

ACCOMPLISHMENT INSTRUCTIONS:

Tail Skid Removal, Modification and Installation

1. Remove the tail skid (3, Figure 1) from the vertical fin (1).
2. Mark the location of the new holes in the tail skid.
3. Drill two holes of 0.176 inches (4.470 mm) diameter to align with the weights (7 and 8). Refer to Figure 1, detail B.
4. Apply a layer of sealant (C-392) on mating surfaces of the weight (8) and the tail skid (3).
5. Apply sealant (C-392) on the faying surfaces of the weights (7 and 8).
6. Install the weights (7 and 8) on the tail skid (3).
7. Apply sealant (C-392) on the bolts (9) and attach the weights (7 and 8) to the tail skid (3) with the bolts (9), the washers (6) and nuts (5) .
8. Apply sealant (C-392) on the two ends of the weight (8).
9. Paint (C-245) tail skid and weight as shown in Figure 2.
10. Install the decal 31-053-18CFHP on the top of the weight assembly (8) and apply a layer of clear paint (C-245) on the decal.
11. Apply sealant (C-308) to the tail skid area of the mount (4, Figure 1) on the vertical fin (1).
12. Put the tail skid (3) into the mount on the vertical fin (1) and install the bolt (10), washers (11), and nut (12) . Safety with the cotter pin (13).

-NOTE-

Make sure you install the nut (12) on the tail rotor side of the vertical fin (1) (refer to Figure 1).

13. Install the RADS-AT equipment (refer to Technical Bulletin 206L-96-187) and do a check for tail rotor vibration. Adjust the vibration to meet the acceptable criteria.
14. Remove the RADS-AT equipment.
15. Make an entry in the Record of Technical Bulletins in the Maintenance Manual and the Illustrated Parts Breakdown to show that you have completed this bulletin.

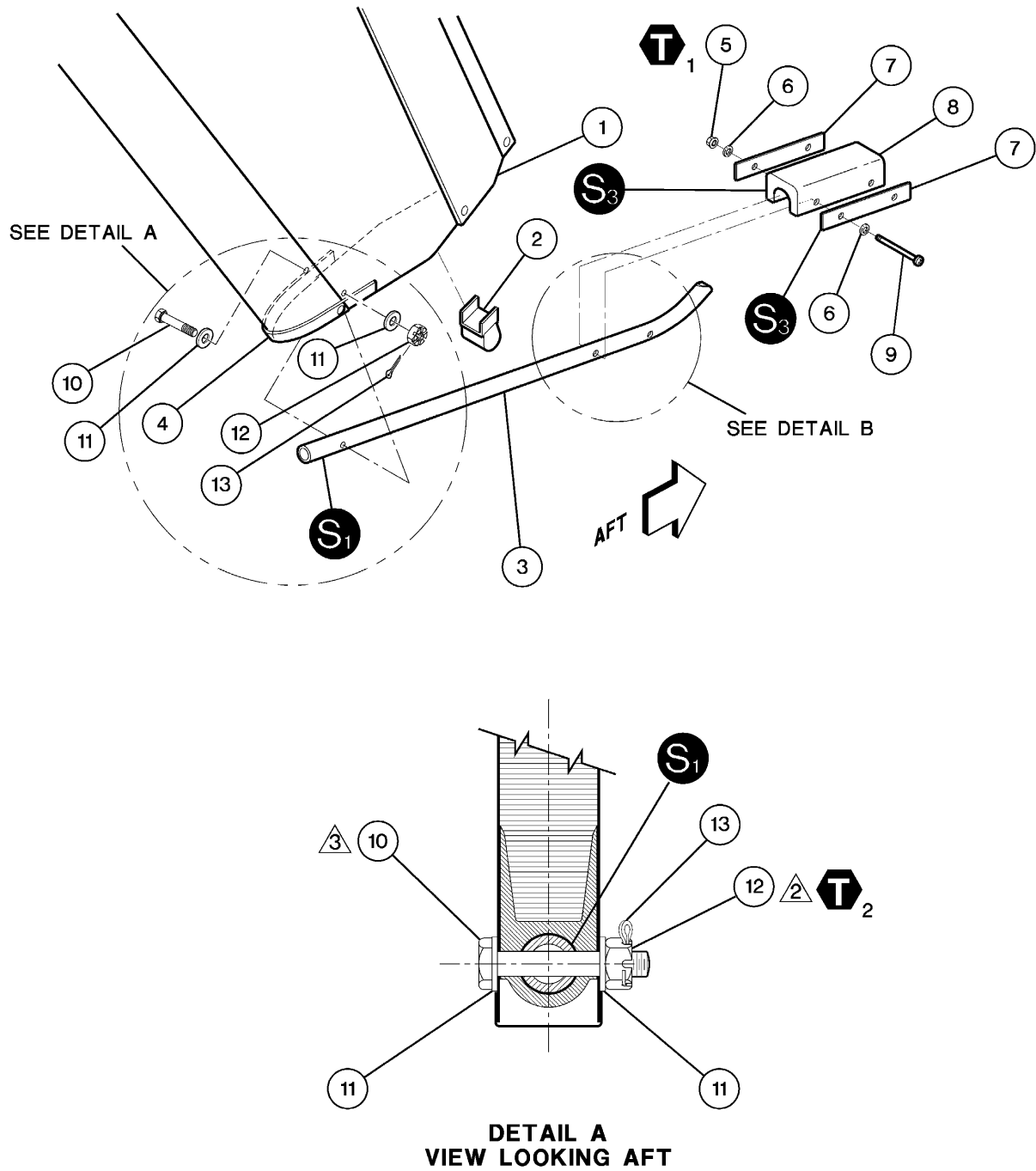
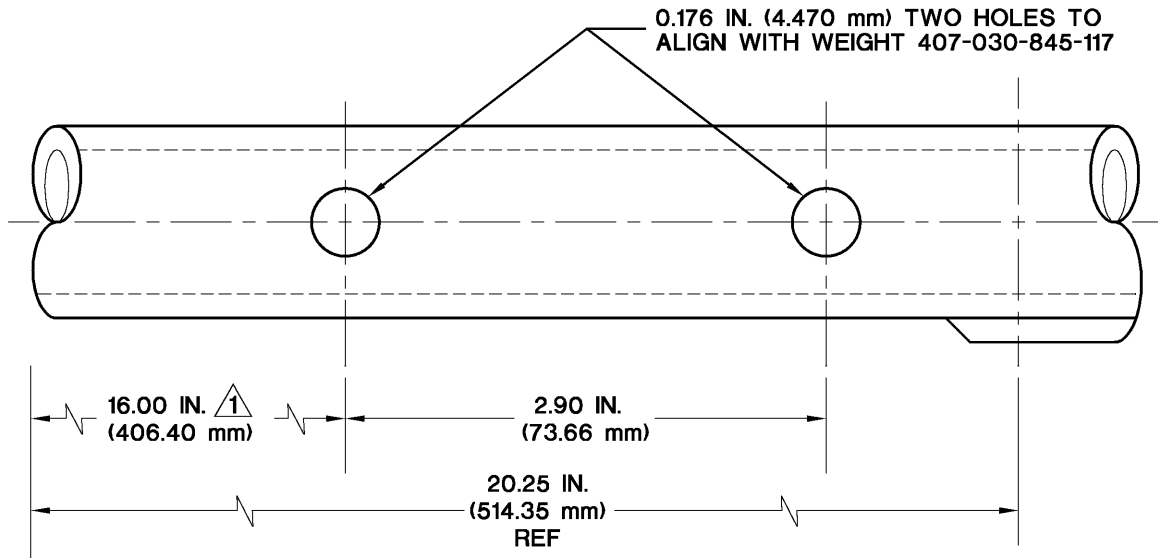

Figure 1. Tail Skid - Removal, Modification, and Installation (Sheet 1)



DETAIL B - WEIGHT INSTALLATION

LEGEND

1. Vertical Fin (Ref.) (206-020113)
2. Bumber (206-020-113-027)
3. Tail Skid (206-020-110-005)
4. Mount (Ref.)
5. Nut (MS21042L08)
6. Washer (NAS1149DN832J)
7. Weight (407-030-845-117)
8. Weight (407-030-845-115)
9. Bolt (Ref.) (MS27039-08)
10. Bolt (NAS6604D20)
11. Washer (NAS1149D0432K)
12. Nut (MS14145L4)
13. Cotter pin (MS24665-151)



50 TO 70 IN-LB
(5.6 TO 7.9 Nm)



25 TO 35 IN-LB
(2.9 TO 3.9 Nm)



Apply sealant (C-308) to tube (3)



Apply sealant (C-392) to tube (3) and weights (7), (8)

NOTES



Measured from forward end of the tube.



Make sure you install the nut (12) on the tail rotor side of the vertical fin (1).



If pin was installed before, drill 0.249 / 0.255 IN. (6.325 / 6.477 mm) dia hole through the vertical fin (1) and the tube (3). Install the bolt (10), the washers (11), and the nut (12).

Figure 1. Tail Skid – Removal, Modification, and Installation (Sheet 2)

