

TECHNICAL BULLETIN
Bell Helicopter **TEXTRON**

A Subsidiary of Textron Inc.

No. 206L-04-217

Date Dec 6, 2004

Page 1 of 4

DATE
REV

MODEL AFFECTED: 206L4

SUBJECT: FREEWHEEL AFT SEAL LUBRICATION,
IMPROVEMENT OF

HELICOPTERS AFFECTED: Model 206L4, S/N 52000 through 52281.

[Model 206L4 helicopters serial number 52282 and subsequent will have the intent of this bulletin accomplished prior to delivery]

COMPLIANCE: At the option of the Customer. Bell Helicopter recommends that the intent of this bulletin be accomplished at the next scheduled overhaul.

DESCRIPTION:

Bell Helicopter has determined that the freewheel aft seal lubrication is improved when a groove is machined in the bearing aft cap shoulder extending the lubrication channel. New bearing aft cap will not be reidentified with a different part number

This bulletin gives instructions to rework the aft bearing cap 406-040-509-101 to latest configuration.

APPROVAL:

The engineering design aspects of this Technical Bulletin are Transport Canada approved.

MANPOWER:

Approximately 1.0 man-hours is required to complete this bulletin during overhaul. Man-hours are based on hands-on time, and may vary with personnel and facilities available.

MATERIALS:

Not required

SPECIAL TOOLS:

None required

WEIGHT AND BALANCE:

Not affected

ELECTRICAL LOAD DATA:

Not affected

REFERENCES:

BHT-206L-CR&O, Reissue 0 – 18 June 1993

Chapter 63, Main Rotor Drive System

PUBLICATIONS AFFECTED:

None affected

ACCOMPLISHMENT INSTRUCTIONS:

1. Locally modify the bearing aft cap as shown in Figure 1. Use a vibrating stylus to identify modified bearing aft cap by adding letter "FM" to the part number on the cap.
2. As an alternate, bearing aft cap may be send to Bell Tennessee for modification. Modified bearing aft cap will be identified be adding the letter "FM" to the part number. For advance scheduling, contact:

Bell Helicopter Tennessee Textron
157 Industrial Park Road

Piney Flats, TN. 37686
Office: 423-538-5114
Fax: 423-538-6198.

3. Make an entry in the helicopter Technical Records to show that this Technical Bulletin is completed.

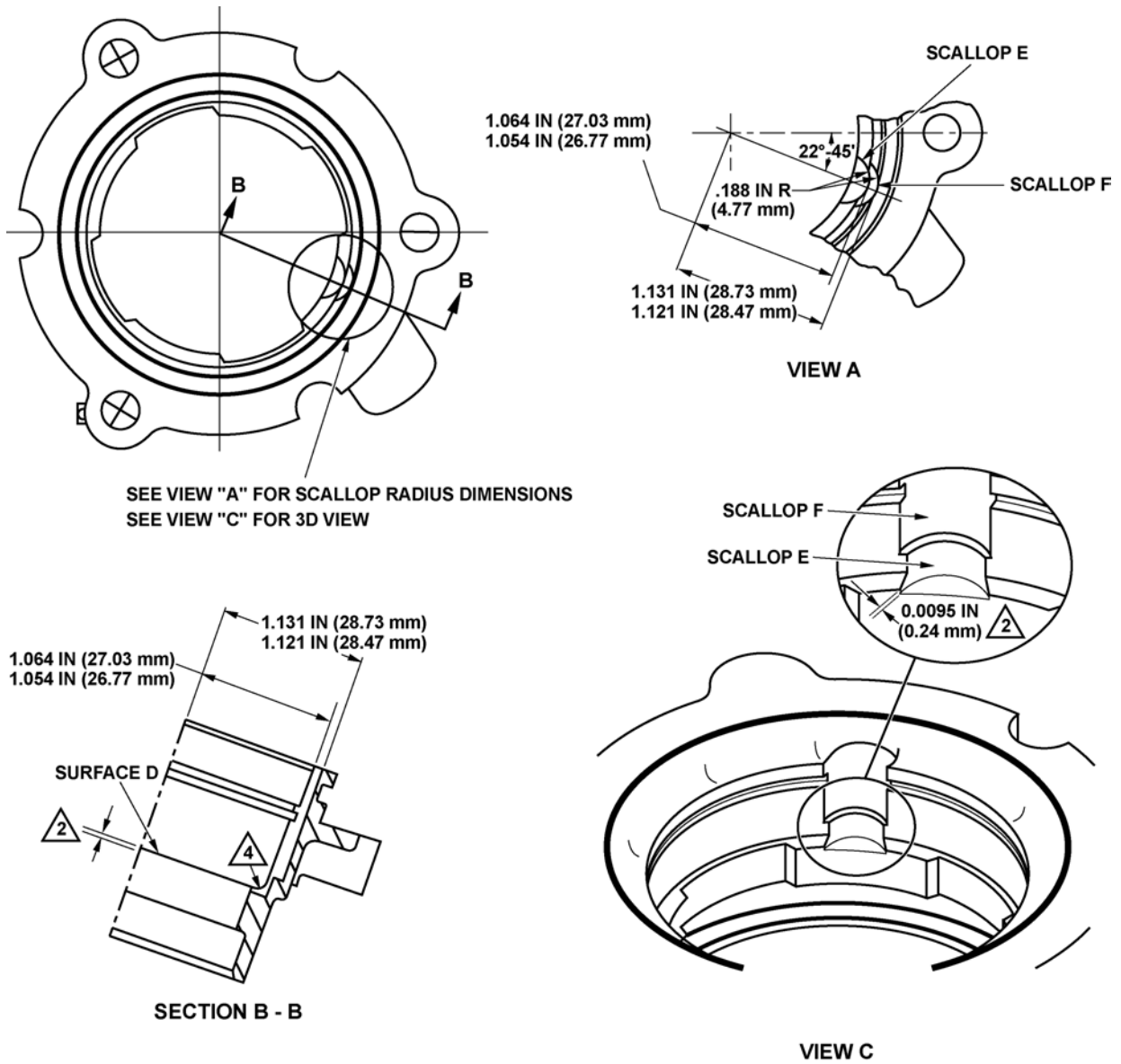

NOTES

1. Surface finish to be 125 u inch RMS
2. Extend the machining of the scallop "E" 0.0095 inch (0.24 mm) ± 0.0025 inch (0.06 mm) below surface D.
3. Break all sharp edges.
4. Scallop radius 0.020 inch (0.508 mm) maximum.

04547001

Figure 1. Instructions to extend the lubrication channel of aft bearing cap 406-040-509-101