

TECHNICAL BULLETIN
Bell Helicopter **TEXTRON**

A Subsidiary of Textron Inc.

No. 212-04-196

Date June 15, 04

Page 1 of 5

DATE
REV

MODEL AFFECTED: 212

SUBJECT: INTAKE SCREEN IMPROVEMENTS

HELICOPTERS AFFECTED: Model 212 helicopters serial number 30502 through 30999, 31101 through 31311, 32101 through 32142 and 35001 through 35103.

[Model 212 helicopters serial number 35104 and subsequent will have the intent of this bulletin accomplished prior to delivery]

COMPLIANCE: At Customer's option

DESCRIPTION:

Bell Helicopter has been made aware of corrosion on small clips attached to engine intake screen assembly P/N 212-061-207-035, especially when operating over salt water. These clips were originally made of aluminum. This bulletin describes a procedure to replace the aluminum parts and existing nutplates of the screen with similar parts made of corrosion resistant steel. Alternatively, the new clips may be made locally or the complete screen replaced with the improved one (P/N 212-061-207-349).

APPROVAL:

The engineering design aspects of this bulletin are FAA/DER approved.

MANPOWER:

Approximately 8.0 man-hours are required to complete this bulletin. Man-hours are based on hands-on time, and may vary with personnel and facilities available.

MATERIALS:**Required Material:**

The following material is required for the accomplishment of this bulletin and may be obtained through your Bell Helicopter Textron Supply Center.

<u>Part Number</u>	<u>Nomenclature</u>	<u>Quantity</u>
212-061-207-351 ¹	Retainer	2
212-061-207-352 ²	Retainer	2
212-061-207-353 ³	Retainer	4
212-061-207-355 ⁴	Retainer	2
MS21060L3	Nutplate	18
MS21062L3	Nutplate	4
MS27039C1-06	Screw	8
NAS1149C0332R	Washer	8

Consumable Material:

The following material is required to accomplish this bulletin, however this material is considered consumable (bench stock) material and may not require ordering depending on the operators consumable material stock levels. This material may be obtained through your Bell Helicopter Textron Supply Center.

<u>Part Number</u>	<u>Nomenclature</u>	<u>Quantity</u>	<u>Reference</u>
MS20427F3	Rivet	A/R	
MS20613-3C	Rivet	A/R	
299-947-107T2CL4 4OZ (or equivalent ⁵)	Adhesive	A/R	C-311
AMS3374/1 6OZ (or equivalent ⁶)	Sealant	A/R	C-353

SPECIAL TOOLS:

None required

WEIGHT AND BALANCE:

Not affected

¹ May be locally fabricated using a 1.2 x 6.2 x 0.040 in. piece of 301 annealed CRES, per AMS 5901

² May be locally fabricated using a 1.2 x 6.2 x 0.040 in. piece of 301 annealed CRES, per AMS 5901

³ May be locally fabricated using a 1.0 x 1.5 x 0.040 in. piece of 301 annealed CRES, per AMS 5901

⁴ May be locally fabricated using a 1.0 x 1.5 x 0.040 in. piece of 301 annealed CRES, per AMS 5901

⁵ EC2126 adhesive or A-1231-B adhesive are acceptable alternates

⁶ Proseal 700 is an acceptable alternate

ELECTRICAL LOAD DATA:

Not affected

REFERENCES:

BHT-212-IPC Illustrated Parts Breakdown
BHT-212-MM Maintenance Manual

PUBLICATIONS AFFECTED:

BHT-212-IPC Illustrated Parts Breakdown

ACCOMPLISHMENT INSTRUCTIONS:

1. Make helicopter ready for maintenance.
2. Open fwd transmission cowling and remove intake cowlings.
3. Open side and upper engine cowlings. Secure open.
4. Remove screens P/N 212-061-207-035 from LH and RH engine intakes.
5. Using a scraper, carefully remove gasket (P/N 212-061-207-061) and retain for reinstallation. Refer to Figure 1.
6. Remove and discard all existing retainers (P/N 212-061-207-097/-098/-099/105) and existing nutplates.
7. Position new retainer (P/N 212-061-207-355) and transfer rivet holes. Countersink nutplate rivet holes and install new retainer and new nutplates using rivets MS20427F3 of appropriate length.
8. Reinstall original gasket using adhesive (C-311).
9. Position new retainers (P/N 212-061-207-351/-352/-353) and transfer rivet holes. Countersink nutplate rivet holes and install new retainers using rivets MS20613-3C of appropriate length and new nutplates using rivets MS20427F3 of appropriate length.
10. Apply sealant (C-353) to fill any void or gap on the screen, specifically in bend relief holes. Allow to dry.

11. Reinstall screens on helicopter using existing hardware on the aft flange and new MS27039C1-06 screws and NAS1149C0332R washers on the side flanges. Reinstall cowlings.
12. Prepare helicopter for flight.
13. Make an entry in helicopter historical records indicating compliance with this technical bulletin.

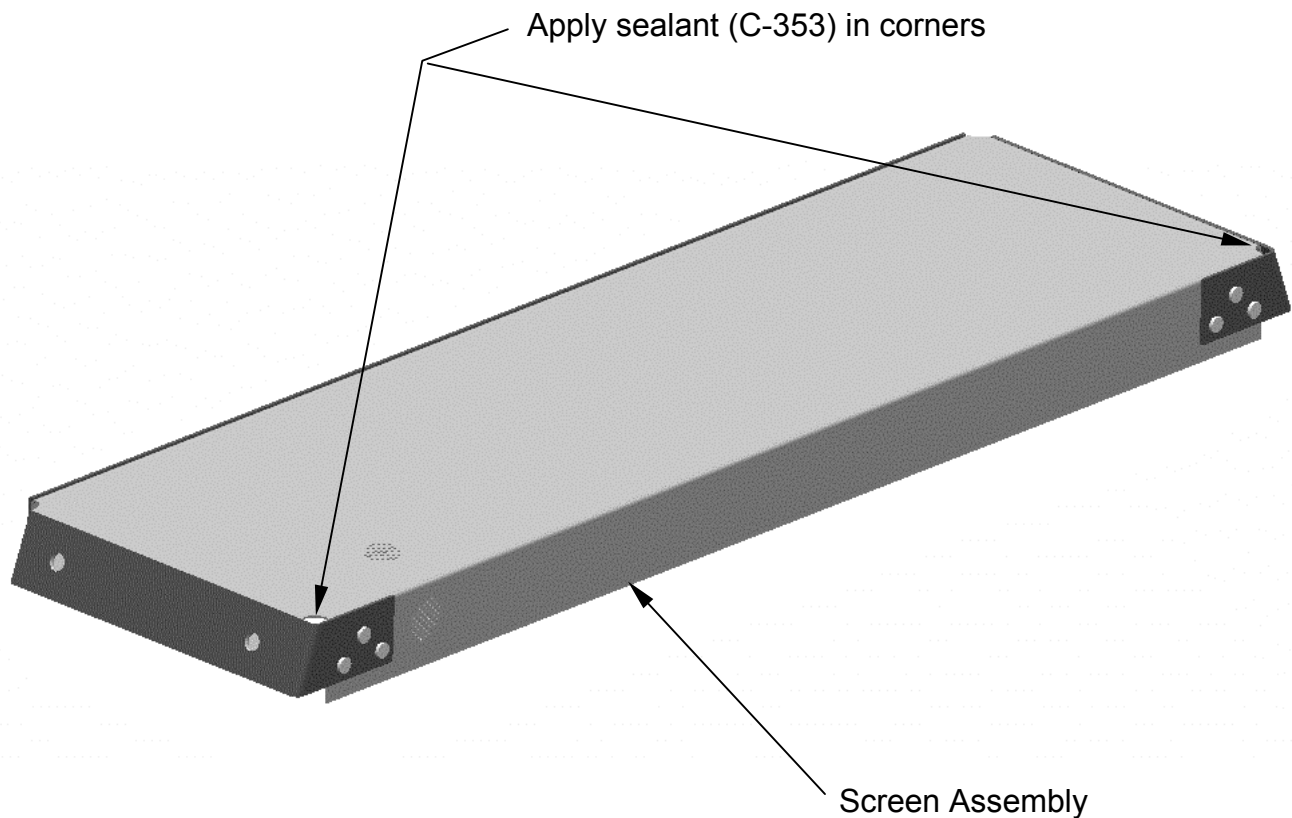

Figure 1 (Sheet 1 of 2)
Screen Assembly
(Isometric view)

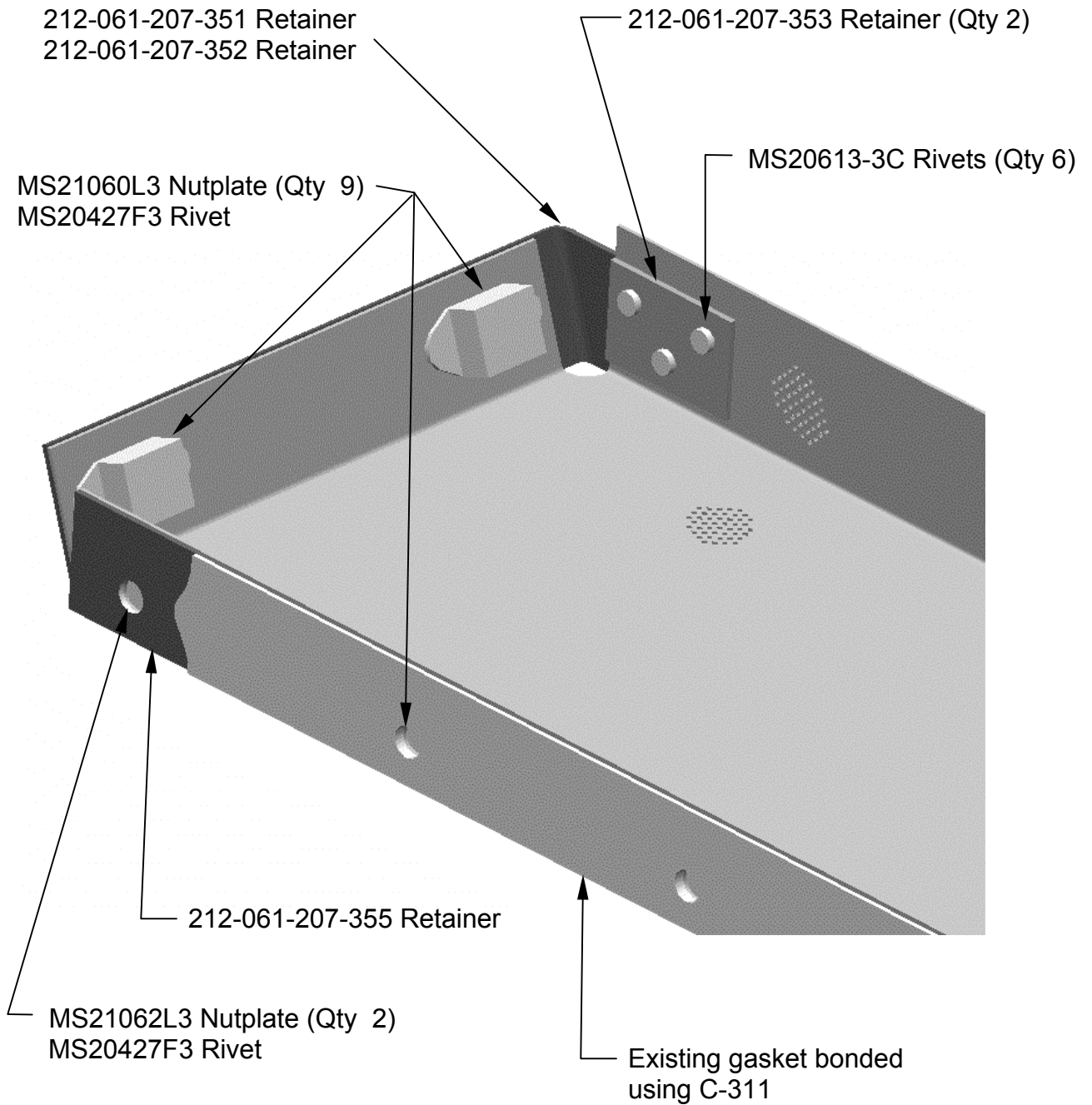

Figure 1 (Sheet 2 of 2)
Screen Assembly
(Detail)

Filename: TB 212-04-196
Directory: D:\My Documents
Template: C:\My Documents\TECH BULL TEMP.dot
Title: TECHNICAL BULLETIN xxx-xx-xxx
Subject:
Author: Bell Helicopter Textron NAL
Keywords:
Comments:
Creation Date: 6/15/2004 3:23 PM
Change Number: 5
Last Saved On: 6/15/2004 4:26 PM
Last Saved By: Bell Helicopter
Total Editing Time: 4 Minutes
Last Printed On: 6/22/2004 3:22 PM
As of Last Complete Printing
Number of Pages: 5
Number of Words: 549 (approx.)
Number of Characters: 3,131 (approx.)