

Bell Helicopter **TEXTRON**

Bell Helicopter Textron Inc.
A Subsidiary of Textron Inc.

Post Office Box 482
Fort Worth, Texas 76101
(817) 280-2011

MARCH 3, 1989

TO: ALL MODEL 214B AND 214B-1 OWNERS/OPERATORS

SUBJECT: REVISION "A" TO TECHNICAL BULLETIN NO. 214-76-4,
HYDRAULIC ACTUATOR, P/N 214-076-146-001 AND
214-076-147-1 BYPASS INDICATOR SWITCH, P/N 41003285

REVISION "A" PROVIDES THE FOLLOWING CHANGES:

- ADDS APPLICABILITY TO HYDRAULIC ACTUATOR, P/N 214-076-146-101.
- ADDS FIGURE 3.
- PROVIDES MORE DETAILED ACCOMPLISHMENT INSTRUCTIONS.

TECHNICAL BULLETIN

NO. 214-76-4

Bell Helicopter **TEXTRON**

DATE 7-8-76

A Subsidiary of Textron Inc.

DATE 3-3-89

REV. A

Post Office Box 482 • Fort Worth, Texas 76101

PAGE NO. 1 of 7

SUBJECT: HYDRAULIC ACTUATOR P/N 214-076-146-001/-101
AND 214-076-147-001 BYPASS INDICATOR SWITCH
P/N 41003285

A

HELICOPTERS AFFECTED: All Model 214B series helicopters

WEIGHT CHANGE: N/A

ACCOMPLISHMENT: When adjustment or replacement of the bypass
indicator switch is required.

A

DESCRIPTION:

Hydraulic actuator servo bypass valve warning indication observed on the indicator light may be caused by a malfunction of the switch, P/N 41003285, mounted on the servo actuator. Prior to replacing an actuator, this switch should be checked for proper function and setting. The following instructions are provided for function testing and setting of the bypass indicator switch. This information will be incorporated in the next revision of the 214B series component repair and overhaul manual.

REPLACING THE BYPASS INDICATOR SWITCH 214B MAIN AND TAIL ROTOR SERVO ACTUATORS

Removal - (Ref. Fig. 1 AND Fig. 2)

1. Gain access to the appropriate main rotor or tail rotor actuator thru the pylon access covers or the aft access door respectively.
2. Disconnect electrical plug.
3. Loosen the retaining nut (2) and turn the bypass indicator switch (1) out of the cap (3). Remove the retaining nut (2) from the indicator switch (1). Remove the cover (5) from the end cap (3). Remove and discard the packing (7) from the cover.

A

A

Replace - (Ref. Fig. 1 and Fig. 2)

A

7851 58913

AN APPROPRIATE ENTRY SHOULD BE MADE IN THE AIRCRAFT LOG BOOK UPON ACCOMPLISHMENT
IF OWNERSHIP OF AIRCRAFT HAS CHANGED PLEASE FORWARD TO NEW OWNER

CAUTION: THE SWITCH PROBE IS LOCATED OFF CENTER IN THE SWITCH SO THAT THE OPERATING POINT OF THE SWITCH CAN BE ADJUSTED BY SIMPLY SCREWING THE SWITCH INTO OR OUT OF THE ACTUATOR HOUSING. BECAUSE THE PROBE IS NOT ON THE CENTERLINE OF THE SWITCH, IT WILL NOT EASILY ENGAGE THE SPRING GUIDE GROOVE WITHOUT ASSISTANCE WHEN THE ASSEMBLY IS SCREWED INTO THE HOUSING. THE PROBE IS EASILY BENT OR DAMAGED IF IT IS NOT PROPERLY GUIDED INTO THE SPRING GUIDE.

1. Install a packing (6) in the groove of the replacement indicating switch. Install the retaining nut (2) fully onto the replacement indicator switch (1) and thread the indicator switch (1) into the cap (3) while viewing the probe on the indicator switch to insure that the probe smoothly enters the groove in the spring guide (4). Moving the pilot input lever will assist in aligning the probe with the spring guide.

CAUTION: THE BODY OF THE INDICATOR SWITCH HAS A LOCKING PELLET, THEREBY REQUIRING A LOT OF TURNING TORQUE, WHICH OBSCURES THE THREADING TORQUE.

2. Thread the indicator switch into the cap (3) until the probe almost makes contact with the bottom of spring guide groove. (Do not bottom out.)

NOTE

Unscrewing the switch from the bottom of the spring guide more than 1.5 turns will disengage the probe from the spring guide.

Adjust - (Ref. Fig. 1)

1. Mount a dial indicator (Ref: T41001280-11 indicator support) so that the probe is indicating against the end of the spring guide (4). See Figure 1. The indicator shall have sufficient capacity to measure $\pm .050$ inch minimum.
2. Attach a continuity measuring device across the indicator switch (1) connector pins A & D so that the switching action can be monitored.
3. Slowly actuate the pilot input lever from the preload position to the extend position; stop; then release and allow the bypass spool to return to the preload position. Slowly actuate the bypass spool from the preload position to the retract position; stop; then release and allow the bypass spool to return to the preload position. Monitor the dial indicator and continuity device. When leaving the preload position, the indicator switch should close within .007 to .012 of the preload position and when returning, should open (break contact) within .004 to .012 of preload position.

A

4. Adjust indicator switch by rotating it in the cap to bring it into proper adjustment. Verify that the probe is still in contact with guide and is not bottomed out in guide.
5. Tighten retainer nut (2) and torque 85 to 95 inch lb.
6. Repeat Step 3 to ensure switch has not moved.

Final Assy - (Ref. Fig. 2)

1. Install a packing (7) in the groove of cover (5).
2. Install the cover (5) and torque 480 to 520 inch lb.
3. Safety wire nut (2) and cover (5).
4. Reconnect electrical plug.

LISTING OF ITEMS

<u>ITEM NO.</u>	<u>PART NUMBER</u>	<u>DESCRIPTION</u>	<u>REQUIRED</u>
1.	41003285	Bypass Indicator Switch	1
2.	41003284	Nut, Retainer	1
3.	41003315	Cap, End (Main Rotor Actuator)	1
	41005066	Cap, End (Tail Rotor Actuator)	1
4.	41003283	Guide, Spring	1
5.	41003317	Cover	1
6.	MS28775-014	Packing, Preformed	1
7.	MS28778-12	Packing, Preformed	1
8.	T41001280-11	Dial Indicator Support (HRT) or Equivalent	Ref.

SERVO VALVE BYPASS INDICATOR SWITCH

A. FUNCTIONAL TEST

1. Secure the bypass indicator switch in a fixture (vise). Mount a dial indicator (± 0.050 minimum range) so that the dial indicator probe indicates against the side of the indicator switch probe (Figure 3).

NOTE

Do not tighten vise excessively or the switch housing will be damaged.

2. Attach a continuity measuring device across the indicator switch (1) connector pins A and D so that the switching action can be monitored.

3. Slowly actuate the indicator switch probe from the static or preload position to the dial indicator retract position (towards the dial indicator). Release and allow the bypass indicator switch probe to return to the preload or static position.
 4. When the indicator switch probe is leaving the preload or static position, the micro-switch should close within .007 to .012 of the preload or static position and when returning, should open (break contact) within .004 to .012 of the preload or static position. Reposition the bypass indicator switch by rotating it 90° and repeat the tests until all four quadrants have been checked.
- B. If the microswitch appears to be working properly but is out of adjustment, readjust the microswitch position to the proper operating limits per Section C.
- C. Adjusting the microswitch.
1. Remove the four screws holding the electrical connector in place. Gently lift the electrical connector for access to the microswitch area. Loosen the two screws locking the switch member. Rotate the switch member while monitoring the indicator switch probe motion. When the microswitch operates per specification, tighten the two locking screws. Use locktite on screws, (refer to Figure 3). Recheck the microswitch after locking in position for proper operation.
 2. Reassemble the electrical connector using gasket and four screws. Safety wire four screws.
 3. Functional test per Section A.
- D. If the microswitch does not appear to be functioning properly, the microswitch may be replaced by removing the switch assembly from the unit, removing the microswitch mounting screws, unsoldering the pin connections and replacing the switch with a properly functioning switch. Adjust for proper operation per Section A.
- E. If the probe is slightly bent or damaged, it may be straightened by carefully restraining the internal end of the probe and applying pressure to the external end of the probe using available shop tools.

CAUTION: THE DIAMETER OF THE PROBE POINT IS MACHINED TO SLIP FIT INTO THE ACTUATOR SPRING GUIDE. ANY LOOSENESS WILL AFFECT THE SWITCH OPERATION.

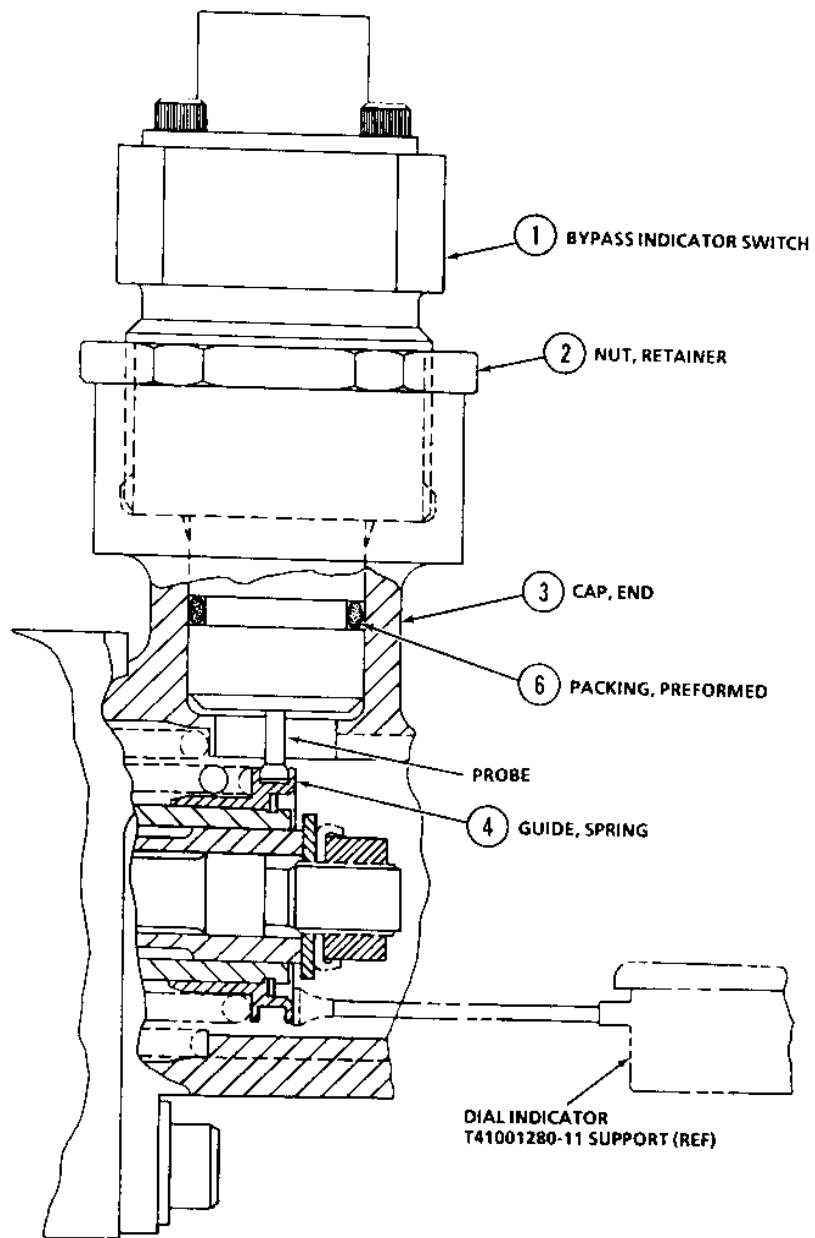

FIGURE 1

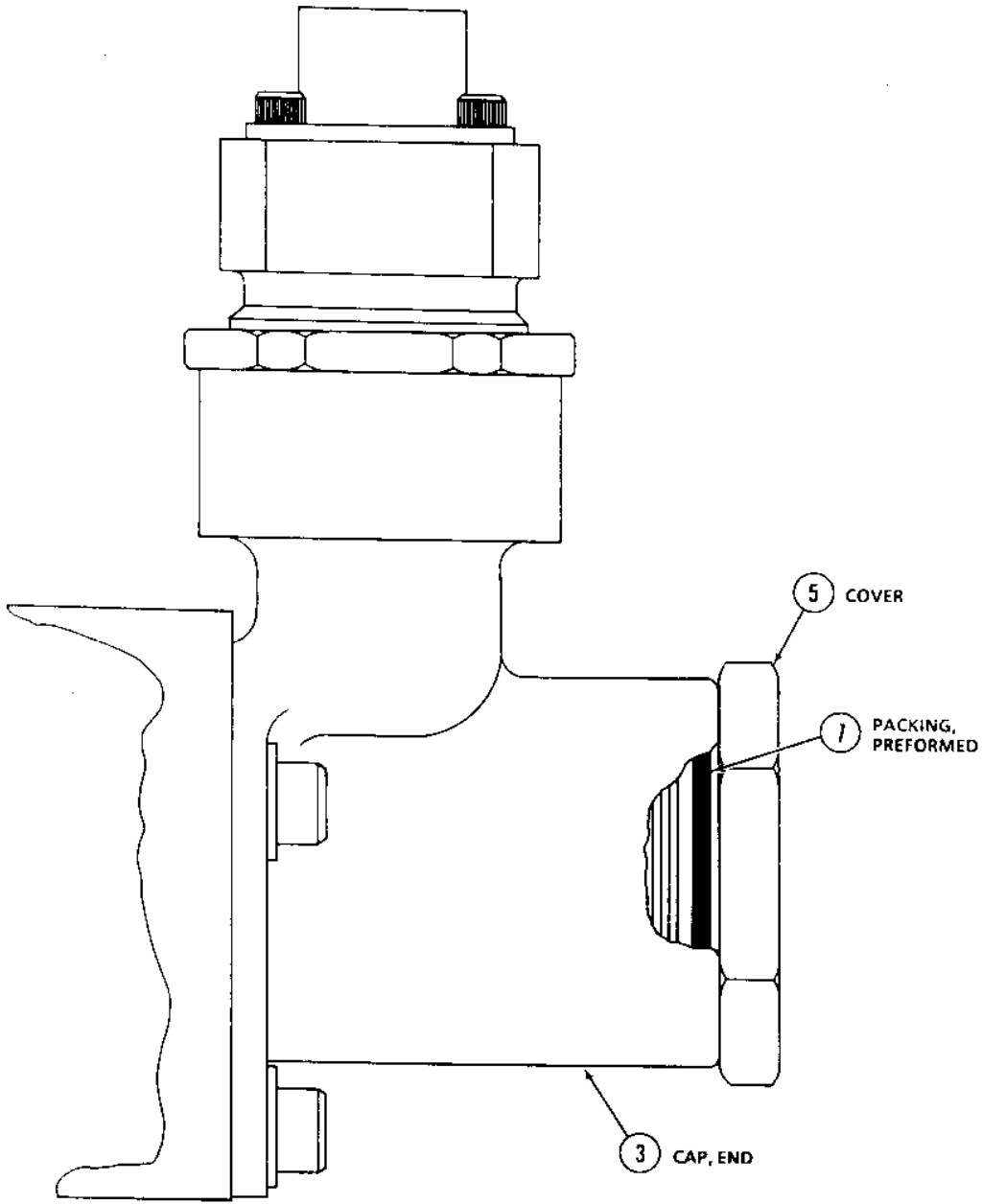

FIGURE 2

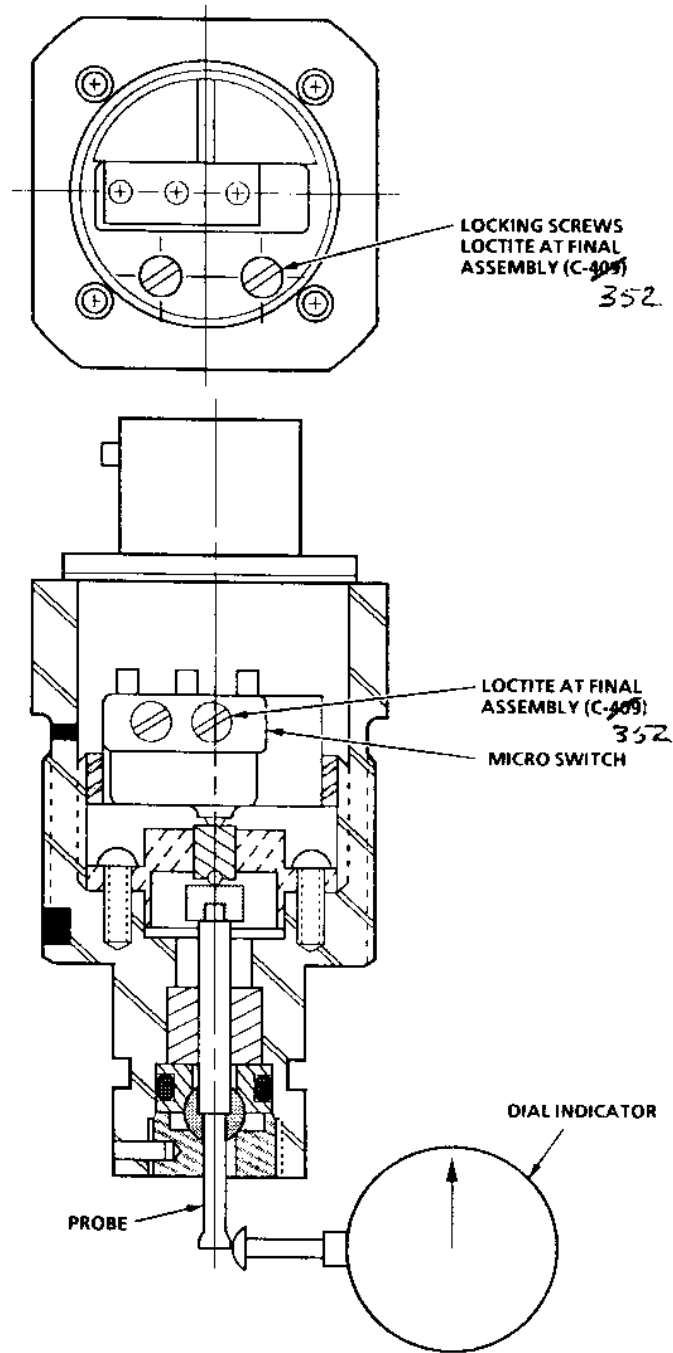

FIGURE 3