

**TECHNICAL BULLETIN**  
**Bell Helicopter** **TEXTRON**

A Subsidiary of Textron Inc.

No. 214ST-02-168

Date 06-11-02

Page 1 of 5

|      |
|------|
| DATE |
| REV  |

**MODEL AFFECTED:** 214ST

**SUBJECT:** INTRODUCTION OF P/N 214-001-133-103  
COLLAR AND MODIFICATION OF EXISTING P/N  
214-001-133-001 COLLAR

**HELICOPTERS AFFECTED:** All Model 214ST Helicopters

**COMPLIANCE:** At Customer's Option

**DESCRIPTION:**

The P/N 41002428 Retainer, which is used to secure the lower portion of the P/N 214-001-094-001 Dust Boot on the P/N 214-076-161 Main Rotor Actuators, was recently changed to improve clearance between its inner diameter and the actuator rod end retaining nut safety wire. This change can create an interference between the new retainer design and the P/N 214-001-133-001 Collar such that the collar may not be free to rotate when the lower end of the dust boot is installed.

This bulletin 1) introduces P/N 214-001-133-103 Collar which has been designed to provide additional clearance with the new retainer, and 2) allows existing P/N 214-001-133-001 Collars to be reworked into the -103 configuration.

**APPROVAL:**

The engineering design aspects of this bulletin are FAA/DER approved.

**MANPOWER:**

Approximately 3.0 man-hours are required to complete this bulletin. Man-hours are based on hands-on time, and may vary with personnel and facilities available.

**MATERIALS:**

None Required.

**SPECIAL TOOLS:**

None required.

**WEIGHT AND BALANCE:**

Not affected.

**ELECTRICAL LOAD DATA:**

Not affected.

**REFERENCES:**

BHT-214ST-IPB Illustrated Parts Breakdown, Chapter 67

BHT-214ST-MM Maintenance Manual, Chapter 67

**PUBLICATIONS AFFECTED:**

BHT-214ST-IPB Illustrated Parts Breakdown, Chapter 67

**ACCOMPLISHMENT INSTRUCTIONS:**

1. Refer to Figure 1 to determine differences between the old P/N 41002428 retainer and the new P/N 41002428 retainer. The P/N 214-001-133-103 Collar supersedes and replaces the -001 Collar.
2. Existing P/N 214-001-133-001 Collars may be field modified into the -103 configuration to fit new retainers as follows (see Figure 2):
  - a. Maintain the split line gap of 0.060 to 0.065 inches during the following steps.
  - b. Using a suitable method, lightly scribe, or mark, the new diameter on both outer surfaces of the collar flanges.
  - c. Using a suitable tool increase the inner diameter of both flanges evenly to the new diameter dimension. Deburr edges.

3. Refer to Figure 1. When installing the P/N 214-001-094 Boot (Item 2) over the P/N 214-001-133 Collar (Item 3) and securing with the clamp (Item 4), the collar must be free to rotate after the clamp is tightened.

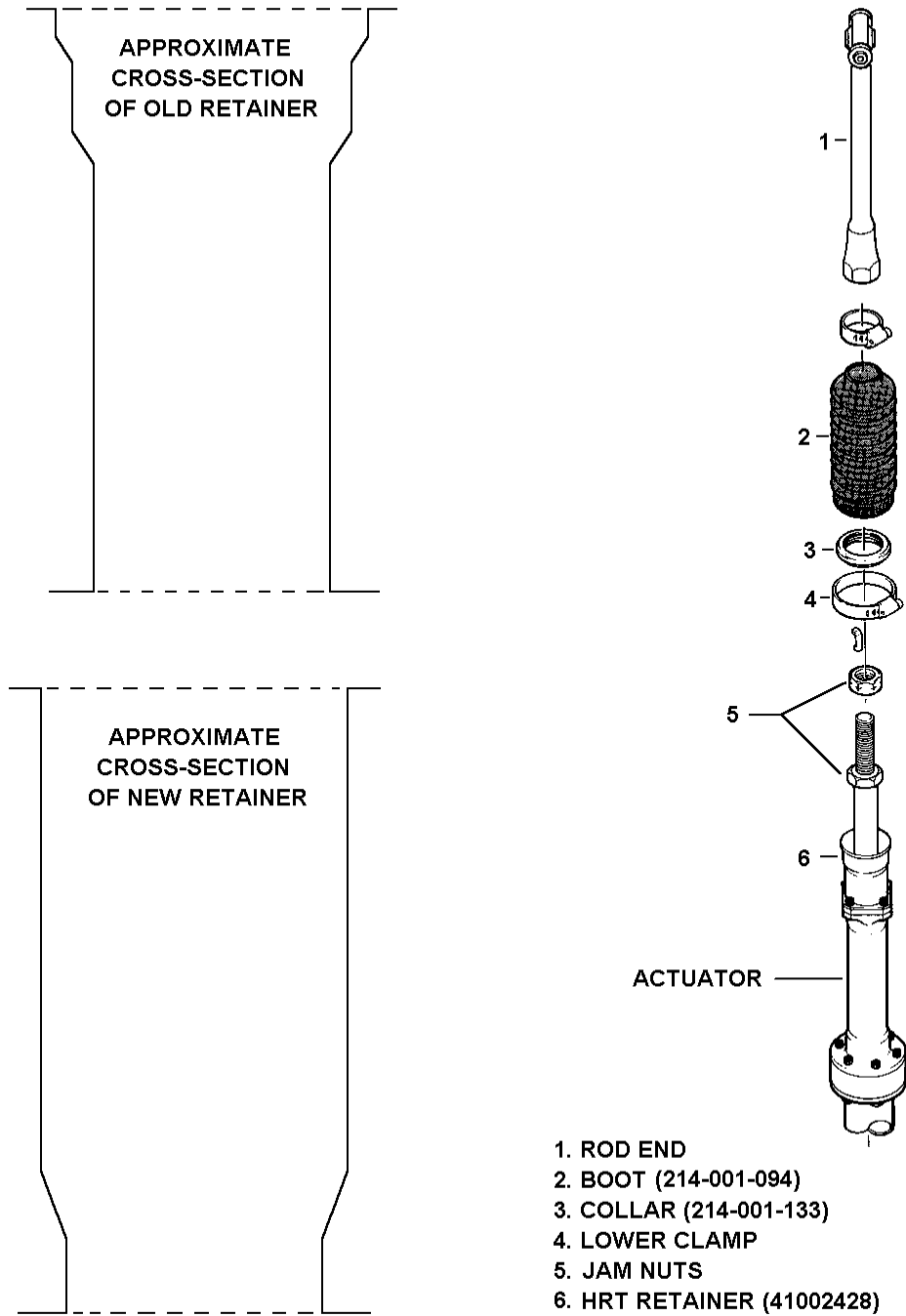
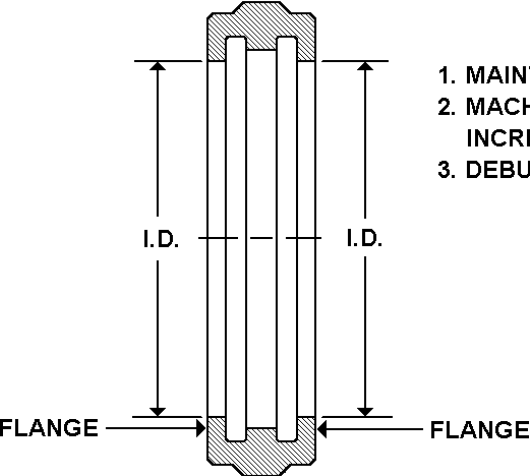
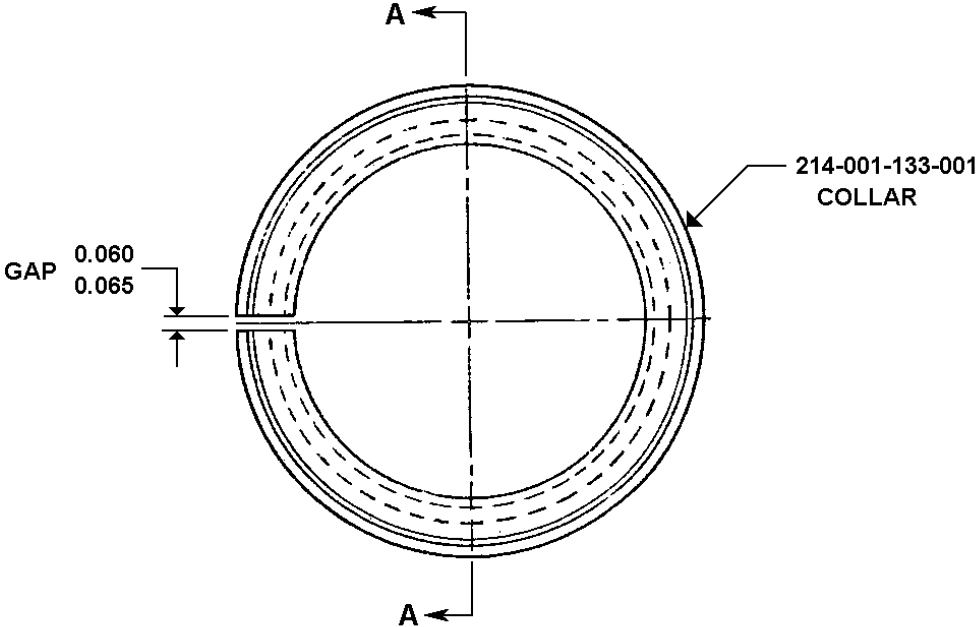

FIGURE 1



- 1. MAINTAIN 0.060 TO 0.065 INCH GAP ON COLLAR.
- 2. MACHINE I.D. OF BOTH FLANGES EVENLY TO INCREASE DIAMETER TO 2.060 +/- 0.010 INCH.
- 3. DEBURR FLANGE EDGES.

SECTION A - A

FIGURE 2