

**TECHNICAL BULLETIN**  
**Bell Helicopter** **TEXTRON**

A Subsidiary of Textron Inc.

No. 222-03-171

Date 06-11-03

Page 1 of 13

DATE
REV

**MODEL AFFECTED:** 222/222B

**SUBJECT:** FUEL VALVE SWITCH, REWIRING OF

**HELICOPTERS AFFECTED:** Model 222 helicopters serial number 47006 through 47089 and Model 222B helicopters serial number 47131 through 47156

**COMPLIANCE:** Bell Helicopter recommends compliance with this bulletin.

**DESCRIPTION:**

We have received field reports of failure of the switches, P/N 10648BH1-1, that control the operation of the No.1 and No. 2 engine fuel valves. There is a possibility that the switch may fail in flight, due to vibration, causing the switch to open and then causing the fuel valve to revert to the closed condition and subsequent shut down of the associated engine.

Part 1 of this bulletin is applicable to Model 222, S/N 47006 – 47038.

Part 2 of this bulletin is applicable to Model 222, S/N 47039 – 47089 and Model 222B, S/N 47131 – 47156.

**APPROVAL:**

The engineering design aspects of this bulletin are Transport Canada approved.

**MANPOWER:**

Approximately 4.0 man-hours are required to complete this bulletin. Man-hours are based on hands-on time, and may vary with personnel and facilities available.

**MATERIALS:**

None

**SPECIAL TOOLS:**

M81969/14-11 Insertion/Extraction tool

**WEIGHT AND BALANCE:**

Not affected

**ELECTRICAL LOAD DATA:**

Not affected

**REFERENCES:**

BHT-222/222B-MM Maintenance Manual

**PUBLICATIONS AFFECTED:**

BHT-222/222B-MM Maintenance Manual

**ACCOMPLISHMENT INSTRUCTIONS:**

**PART 1 – Model 222, S/N 47006 - 47038**

1. Prepare the helicopter for maintenance
2. Ensure all electrical power is removed from the helicopter.
3. Disconnect the aircraft battery.
4. Carefully lower the overhead console.
5. Locate the No.1 engine Fuel Valve Switch (1S3).
6. Using an extraction tool, P/N M81969/14-11, remove the following wires from switch (1S3):

J5A24 from position 7,  
J6A24 from position 8,  
L123A24 from position 10,  
L122A24 from position 11.  
Q146A24 from position 16,  
Q144A24 from position 17.

7. Using an insertion tool, P/N M81969/14-11, insert the following wires into switch (1S3):
  - J5A24 into position 5,
  - J6A24 into position 6,
  - L122A24 into position 10,
  - L123A24 into position 11,
  - Q144A24 into position 16,
  - Q146A24 into position 17.
8. Locate the No.2 engine Fuel Valve Switch (1S8).
9. Using an extraction tool, P/N M81969/14-11, remove the following wires from switch (1S8):
  - J1A24 from position 7,
  - J2A24 from position 8,
  - L109A24 from position 10,
  - L108A24 from position 11.
  - Q141A24 from position 16,
  - Q140A24 from position 17.
10. Using an insertion tool, P/N M81969/14-11, insert the following wires into switch (1S8):
  - J1A24 into position 5,
  - J2A24 into position 6,
  - L108A24 into position 10,
  - L109A24 into position 11,
  - Q140A24 into position 16,
  - Q141A24 into position 17.
11. Carefully raise the overhead control console and re-secure.
12. Push the ENG 1 FUEL VALVE switch (1S3) and the ENG 2 FUEL VALVE switch (1S8) to the "in" position.
13. Apply a 28 Vdc power source to the aircraft. (BHT-222/222B-MM-2).
14. Push the ENG 1 FUEL VALVE switch (1S3) to ON and observe the following:
  - a. The green light of the switch comes on.
  - b. The engine No.1 fuel valve opens.
  - c. The ENG 1 FUEL VALVE caution panel segment will come on for as long as the fuel shut valve is operating.
15. Push the ENG 2 FUEL VALVE switch (1S3) to ON and observe the following:

- a. The green light of the switch comes on.
  - b. The engine No.2 fuel valve opens.
  - c. The ENG 2 FUEL VALVE caution panel segment will come on for as long as the fuel shut valve is operating.
16. Open the engine No.1 and engine No.2 FIRE EXTG circuit breakers (24CB1 and 24CB2).
17. Set the ENGINE 1 ARM fire extinguisher switch to ARM and observe the following:
- a. The engine No.1 fuel valve closes.
  - b. The ENG 1 FUEL VALVE caution panel segment will come on for as long as the fuel shut valve is operating.
18. Set the ENGINE 1 ARM fire extinguisher switch to NORM and the ENG 1 FUEL VALVE switch to OFF.
19. Set the ENGINE 2 ARM fire extinguisher switch to ARM and observe the following:
- a. The engine No.2 fuel valve closes.
  - b. The ENG 2 FUEL VALVE caution panel segment will come on for as long as the fuel shut valve is operating.
20. Set the ENGINE 2 ARM fire extinguisher switch to NORM and the ENG 2 FUEL VALVE switch to OFF.
21. Close the engine No.1 and engine No.2 FIRE EXTG circuit breakers (24CB1 and 24CB2).
21. Carry out an operational test of the ignitor system. (BHT-222/222B-MM-2).
22. Annotate the helicopter records to reflect compliance with this bulletin.
23. Return the helicopter to flight status.

**PART 2 – Model 222, S/N 47039 – 47089 and Model 222B, S/N 47131 - 47156**

1. Prepare helicopter for maintenance.
2. Ensure that all electrical power is removed from the helicopter and aircraft battery is disconnected.
3. Carefully lower the overhead console.
4. Locate the No.1 engine Fuel Valve Switch (1S3).
5. Using an extraction tool, P/N M81969/14-11, remove the following wires from switch (1S3):

- Q151A24 from position 5,
  - Q151C24 from position 6,
  - J5A24 from position 7,
  - J6A24 from position 8,
  - L123A24 from position 10,
  - L122A24 from position 11.
  - Q227A24N from position 14,
  - Q146A24 from position 16,
  - Q144A24 from position 17,
6. Using an insertion tool, P/N M81969/14-11, insert the following wires into switch (1S3):
- J5A24 into position 5,
  - J6A24 into position 6,
  - Q151A24 into position 7,
  - Q151C24 into position 8,
  - L122A24 into position 10,
  - L123A24 into position 11,
  - Q227A24N into position 13,
  - Q144A24 into position 16,
  - Q146A24 into position 17,
7. Locate the No.2 engine Fuel Valve Switch (1S8).
8. Using an extraction tool, P/N M81969/14-11, remove the following wires from switch (1S8):
- J1A24 from position 7,
  - J2A24 from position 8,
  - Q149A24 from position 5,
  - Q149C24 from position 6,
  - L109A24 from position 10,
  - L108A24 from position 11.
  - Q228A24N from position 14,
  - Q141A24 from position 16,
  - Q140A24 from position 17,

9. Using an insertion tool, P/N M81969/14-11, insert the following wires into switch (1S8):
  - J1A24 into position 5,
  - J2A24 into position 6,
  - Q149A24 into position 7,
  - Q149C24 into position 8,
  - L108A24 into position 10,
  - L109A24 into position 11,
  - Q228A22N into position 13,
  - Q140A24 into position 16,
  - Q141A24 into position 17,
10. Carefully raise the overhead control console and re-secure.
11. Push the ENG 1 FUEL VALVE switch (1S3) and the ENG 2 FUEL VALVE switch (1S8) to the "in" position.
12. Apply a 28 Vdc power source to the aircraft. (BHT-222/222B-MM-2).
13. Push the ENG 1 FUEL VALVE switch (1S3) to ON and observe the following:
  - a. The green light of the switch comes on.
  - b. The engine No.1 fuel valve opens.
  - c. The ENG 1 FUEL VALVE caution panel segment will come on for as long as the fuel shut valve is operating.
14. Push the ENG 2 FUEL VALVE switch (1S3) to ON and observe the following:
  - a. The green light of the switch comes on.
  - b. The engine No.2 fuel valve opens.
  - c. The ENG 2 FUEL VALVE caution panel segment will come on for as long as the fuel shut valve is operating.
15. Open the engine No.1 and engine No.2 FIRE EXTG circuit breakers (24CB1 and 24CB2)
16. Set the ENGINE 1 ARM fire extinguisher switch to ARM and observe the following:
  - a. The engine No.1 fuel valve closes.
  - b. The ENG 1 FUEL VALVE caution panel segment will come on for as long as the fuel shut valve is operating.
17. Set the ENGINE 1 ARM fire extinguisher switch to NORM and the ENG 1 FUEL VALVE switch to OFF.

18. Set the ENGINE 2 ARM fire extinguisher switch to ARM and observe the following:
  - a. The engine No.2 fuel valve closes.
  - b. The ENG 2 FUEL VALVE caution panel segment will come on for as long as the fuel shut valve is operating.
19. Set the ENGINE 2 ARM fire extinguisher switch to NORM and the ENG 2 FUEL VALVE switch to OFF.
20. Close the engine No.1 and engine No.2 FIRE EXTG circuit breakers (24CB1 and 24CB2).
21. Carry out an operational test of the ignitor system. (BHT-222/222B-MM-2).
22. Annotate the helicopter records to reflect compliance with this bulletin.
23. Return the helicopter to flight status.

<b>RE-TERMINATION WIRE CHART MODEL 222 S/N 47006 TO 47038</b>			
<b>WIRE NO.</b>	<b>REF DES</b>	<b>FROM PIN</b>	<b>TO PIN</b>
J5A24	1S3	7	5
J6A24	1S3	8	6
L122A24	1S3	11	10
L123A24	1S3	10	11
Q144A24	1S3	17	16
Q146A24	1S3	16	17
JIA24	1S8	7	5
J2A24	1S8	8	6
L108A24	1S8	11	10
L109A24	1S8	10	11
Q140A24	1S8	17	16
Q141A24	1S8	16	17

<b>RE-TERMINATION WIRE CHART MODEL 222 S/N 47039 TO 47089 AND MODEL 222B S/N 47131 TO 47156</b>			
<b>WIRE NO.</b>	<b>REF DES</b>	<b>FROM PIN</b>	<b>TO PIN</b>
J5A24	1S3	7	5
J6A24	1S3	8	6
L122A24	1S3	11	10
L123A24	1S3	10	11
Q144A24	1S3	17	16
Q146A24	1S3	16	17
Q227A24N	1S3	14	13
Q151A24	1S3	5	7
Q151C24	1S3	6	8
JIA24	1S8	7	5
J2A24	1S8	8	6
L108A24	1S8	11	10
L109A24	1S8	10	11
Q140A24	1S8	17	16
Q141A24	1S8	16	17
Q149A24	1S8	5	7
Q149C24	1S8	6	8
Q228A24N	1S8	14	13

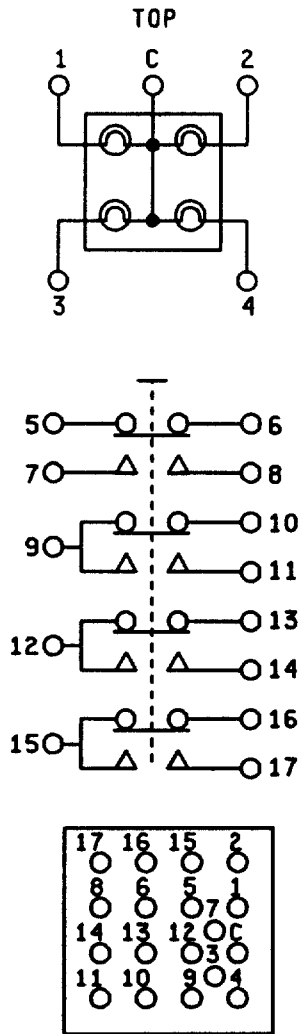

**Figure 2**  
**Switch Termination Schematic**



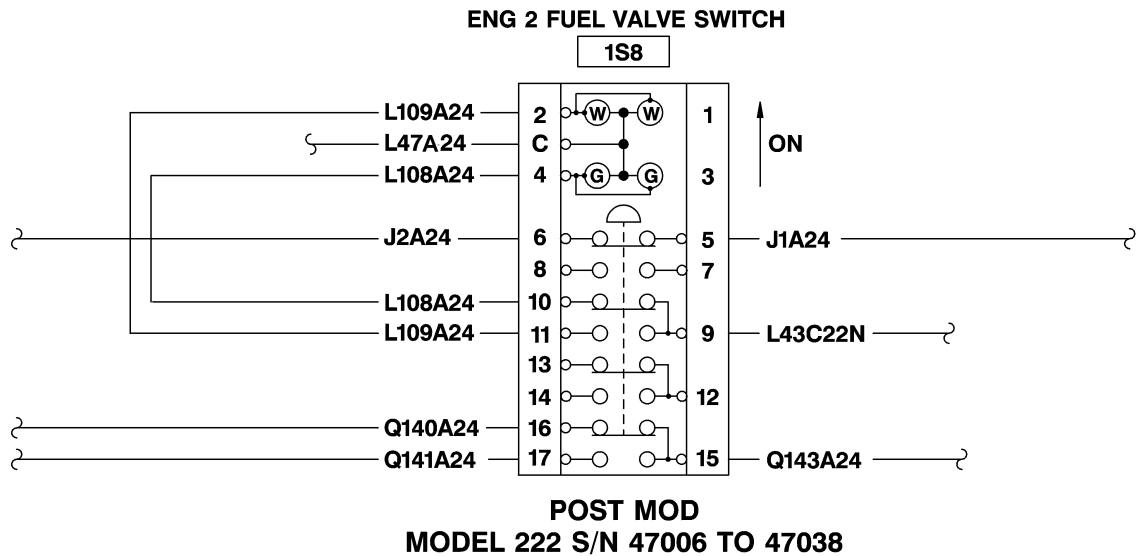
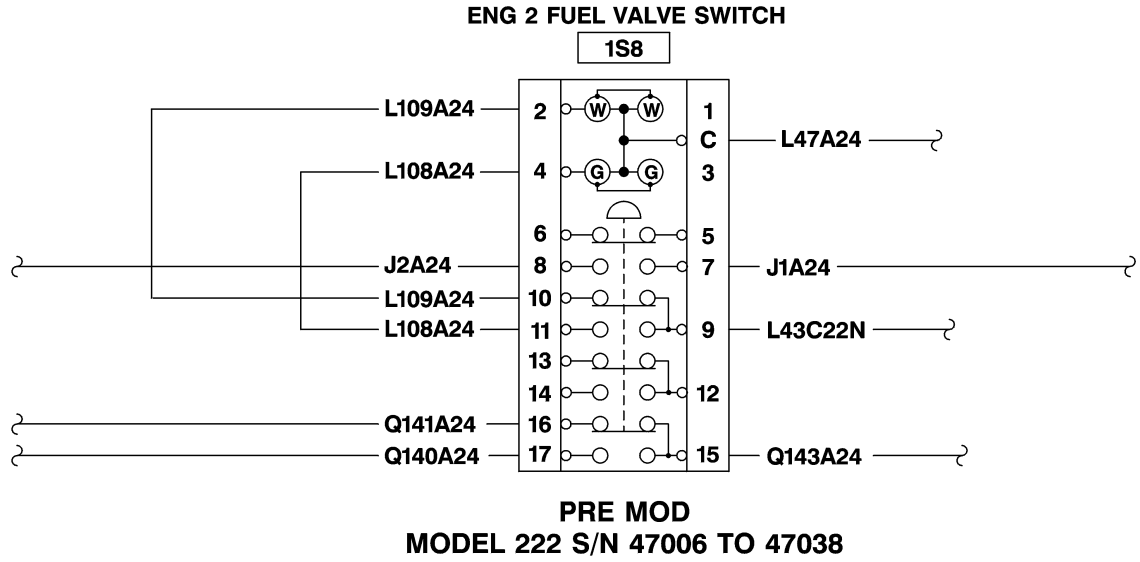

03535002

**Figure 4**  
**No.2 Fuel Valve Switch Wiring Diagram**

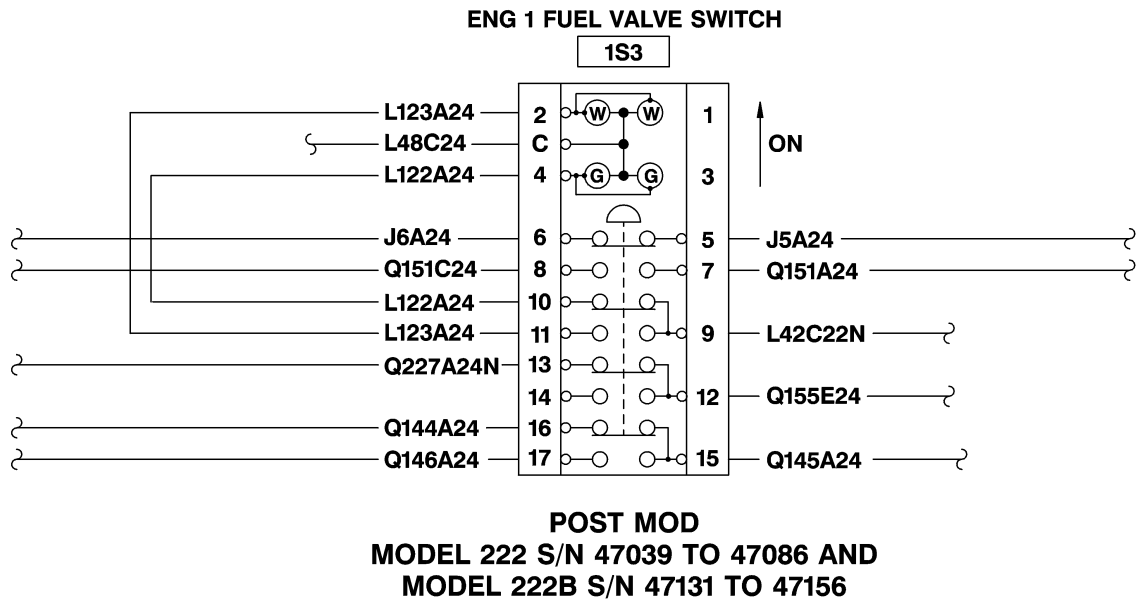
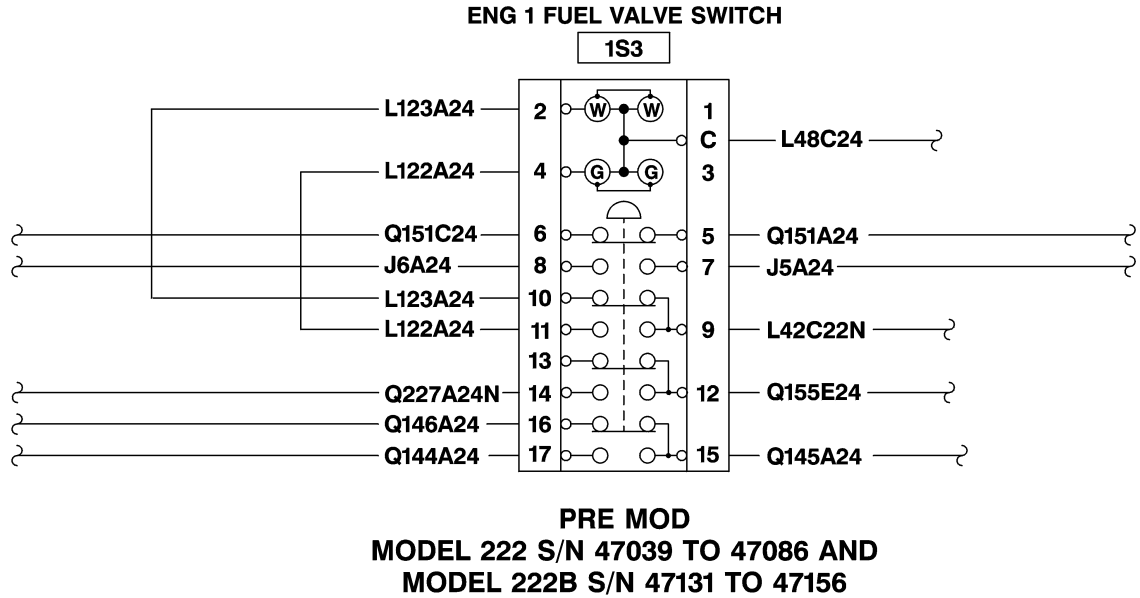

03535003

**Figure 5**  
**No.1 Fuel Valve Switch Wiring Diagram**

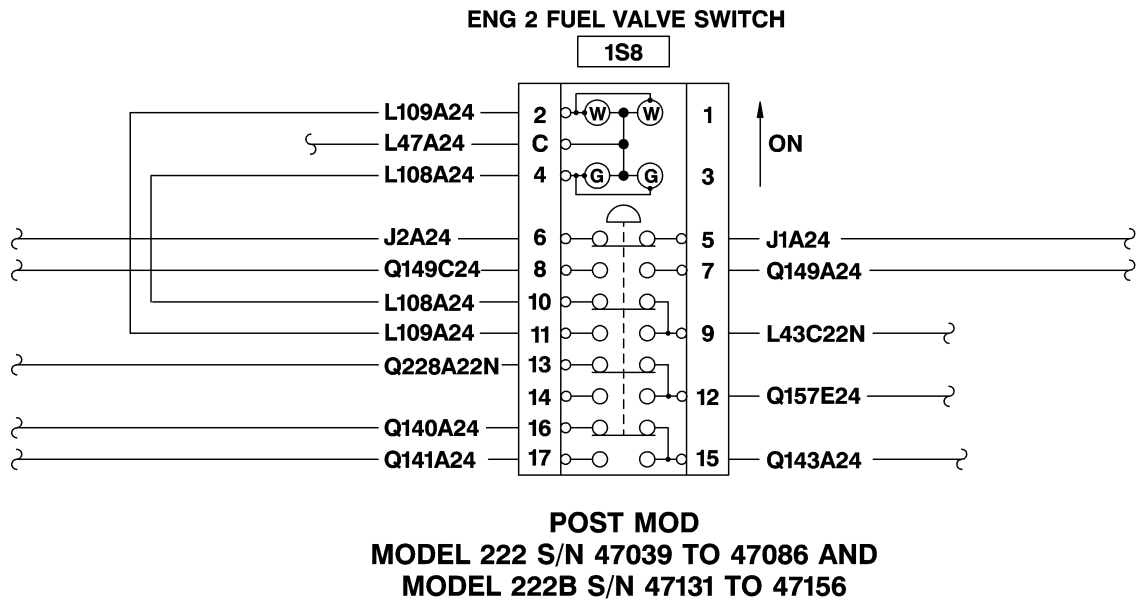
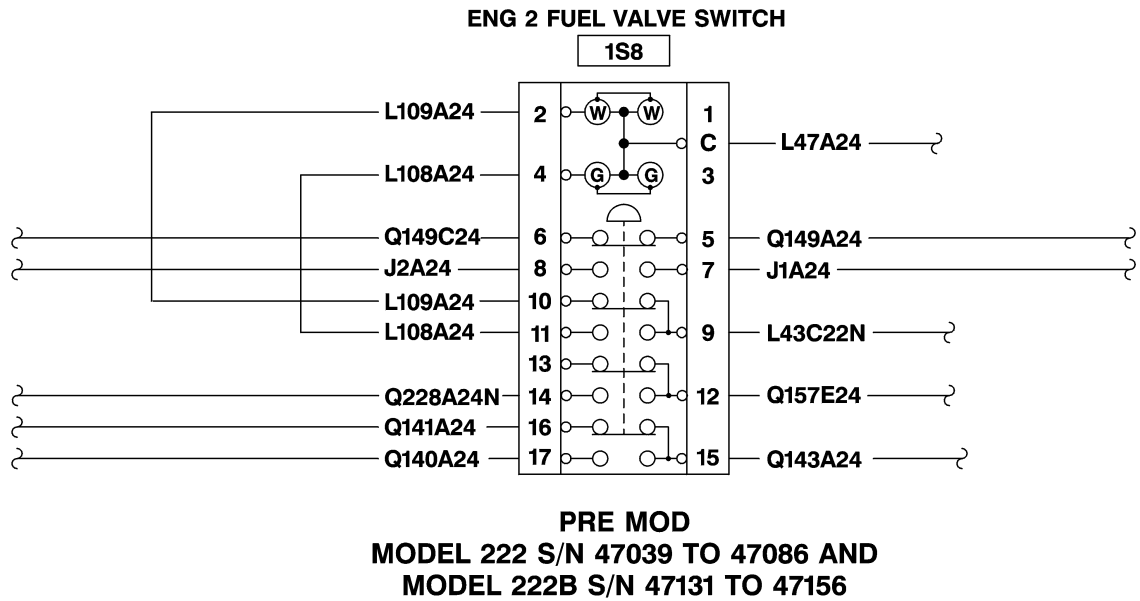

03535004

**Figure 6**  
**No.2 Fuel Valve Switch Wiring Diagram**