

TECHNICAL BULLETIN
Bell Helicopter **TEXTRON**

A Subsidiary of Textron Inc.

No. 222U-03-96

Date 06-11-03

Page 1 of 8

DATE
REV

MODEL AFFECTED: 222U

SUBJECT: FUEL VALVE SWITCH, REWIRING OF

HELICOPTERS AFFECTED: Model 222U helicopters serial number 47501 through 47574

COMPLIANCE: Bell Helicopter recommends compliance with this bulletin.

DESCRIPTION:

We have received field reports of failure of the switches, P/N 10648BH1-1, that control the operation of the No.1 and No. 2 engine fuel valves. There is a possibility that the switch may fail in flight, due to vibration, causing the switch to open and then causing the fuel valve to revert to the closed condition and subsequent shut down of the associated engine.

APPROVAL:

The engineering design aspects of this bulletin are Transport Canada approved.

MANPOWER:

Approximately 4.0 man-hours are required to complete this bulletin. Man-hours are based on hands-on time, and may vary with personnel and facilities available.

MATERIALS:

None

SPECIAL TOOLS:

M81969/14-11 Insertion/Extraction tool

WEIGHT AND BALANCE:

Not affected

ELECTRICAL LOAD DATA:

Not affected

REFERENCES:

BHT-222U-MM-10 Maintenance Manual

BHT-222U-MM-12 Maintenance Manual

PUBLICATIONS AFFECTED:

BHT-222U-MM-10 Maintenance Manual

BHT-222U-MM-12 Maintenance Manual

ACCOMPLISHMENT INSTRUCTIONS:

1. Prepare the helicopter for maintenance
2. Ensure all electrical power is removed from the helicopter.
3. Disconnect the aircraft battery.
4. Carefully lower the overhead console.
5. Locate the No.1 engine Fuel Valve Switch (1S3).
6. Using an extraction tool, P/N M81969/14-11, remove the following wires from switch (1S3):
 - Q151A22 from position 5,
 - Q121A22 from position 6,
 - J5A22 from position 7,
 - J6A22 from position 8,
 - L123A22 from position 10,
 - L122A22 from position 11.
 - Q227A22N from position 14,
 - Q146A22 from position 16,
 - Q144A22 from position 17.
7. Using an insertion tool, P/N M81969/14-11, insert the following wires into switch (1S3):
 - J5A22 into position 5,
 - J6A22 into position 6,

Q151A22 into position 7,
Q121A22 into position 8,
L122A22 into position 10,
L123A22 into position 11,
Q227A22N into position 13,
Q144A22 into position 16,
Q146A22 into position 17.

8. Locate the No.2 engine Fuel Valve Switch (1S8).
9. Using an extraction tool, P/N M81969/14-11, remove the following wires from switch (1S8):

Q149A22 from position 5,
Q148B22 from position 6,
J1A22 from position 7,
J2A22 from position 8,
L109A22 from position 10,
L108A22 from position 11.
Q228A22N from position 14,
Q141A22 from position 16,
Q140A22 from position 17.

10. Using an insertion tool, P/N M81969/14-11, insert the following wires into switch (1S8):

J1A22 into position 5,
J2A22 into position 6,
Q149A22 into position 7,
Q148B22 into position 8,
L108A22 into position 10,
L109A22 into position 11,
Q228A22N into position 13,
Q140A22 into position 16,
Q141A22 into position 17.

11. Carefully raise the overhead control console and re-secure.
12. Push the ENG 1 FUEL VALVE switch (1S3) and the ENG 2 FUEL VALVE switch (1S8) to the "in" position.
13. Apply a 28 Vdc power source to the aircraft. (BHT-222U-MM-10).
14. Push the ENG 1 FUEL VALVE switch (1S3) to ON and observe the following:
 - a. The green light of the switch comes on.
 - b. The engine No.1 fuel valve opens.

- c. The ENG 1 FUEL VALVE caution panel segment will come on for as long as the fuel shut valve is operating..
15. Push the ENG 2 FUEL VALVE switch (1S3) to ON and observe the following:
 - a. The green light of the switch comes on.
 - b. The engine No.2 fuel valve opens.
 - c. The ENG 2 FUEL VALVE caution panel segment will come on for as long as the fuel shut valve is operating.
16. Open the engine No.1 and engine No.2 FIRE EXTG circuit breakers (24CB1 and 24CB2).
17. Set the ENGINE 1 ARM fire extinguisher switch to ARM and observe the following:
 - a. The engine No.1 fuel valve closes.
 - b. The ENG 1 FUEL VALVE caution panel segment will come on for as long as the fuel shut valve is operating.
18. Set the ENGINE 1 ARM fire extinguisher switch to NORM and the ENG 1 FUEL VALVE switch to OFF.
19. Set the ENGINE 2 ARM fire extinguisher switch to ARM and observe the following:
 - a. The engine No.2 fuel valve closes.
 - b. The ENG 2 FUEL VALVE caution panel segment will come on for as long as the fuel shut valve is operating.
20. Set the ENGINE 2 ARM fire extinguisher switch to NORM and the ENG 2 FUEL VALVE switch to OFF.
21. Close the engine No.1 and engine No.2 FIRE EXTG circuit breakers (24CB1 and 24CB2).
21. Carry out an operational test of the ignitor system. (BHT-222U-MM-10).
22. Annotate the helicopter records to reflect compliance with this bulletin.
23. Return the helicopter to flight status.

RE-TERMINATION WIRE CHART			
WIRE NO.	REF DES	FROM PIN	TO PIN
J5A22	1S3	7	5
J6A22	1S3	8	6
L122A22	1S3	11	10
L123A22	1S3	10	11
Q121A22	1S3	6	8
Q144A22	1S3	17	16
Q146A22	1S3	16	17
Q151A22	1S3	5	7
Q227A22N	1S3	14	13
J1A22	1S8	7	5
J2A22	1S8	8	6
L108A22	1S8	11	10
L109A22	1S8	10	11
Q140A22	1S8	17	16
Q141A22	1S8	16	17
Q148B22	1S8	6	8
Q149A22	1S8	5	7
Q228A22N	1S8	14	13

Figure 1
Wire Termination Chart

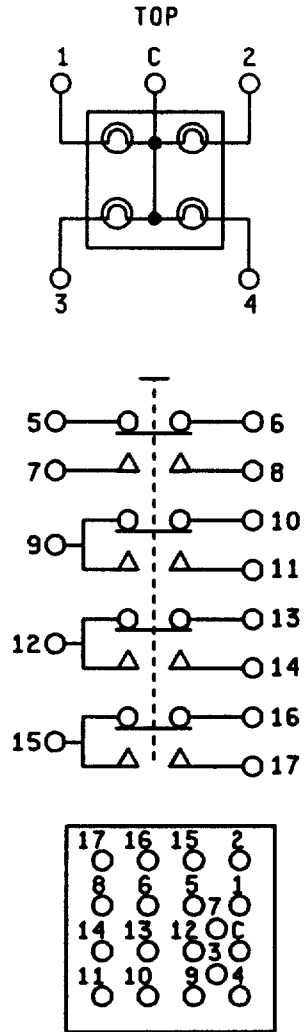
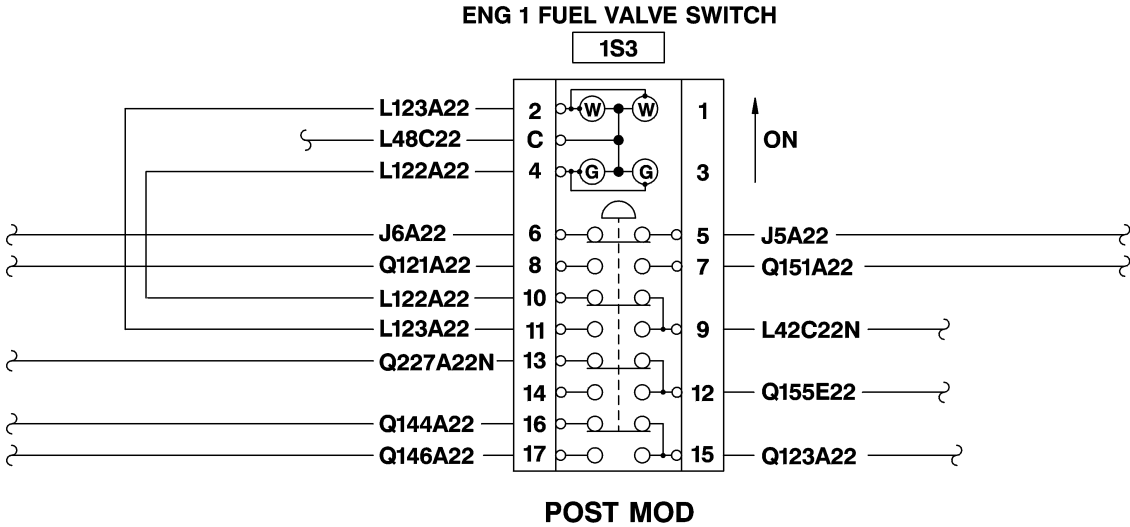
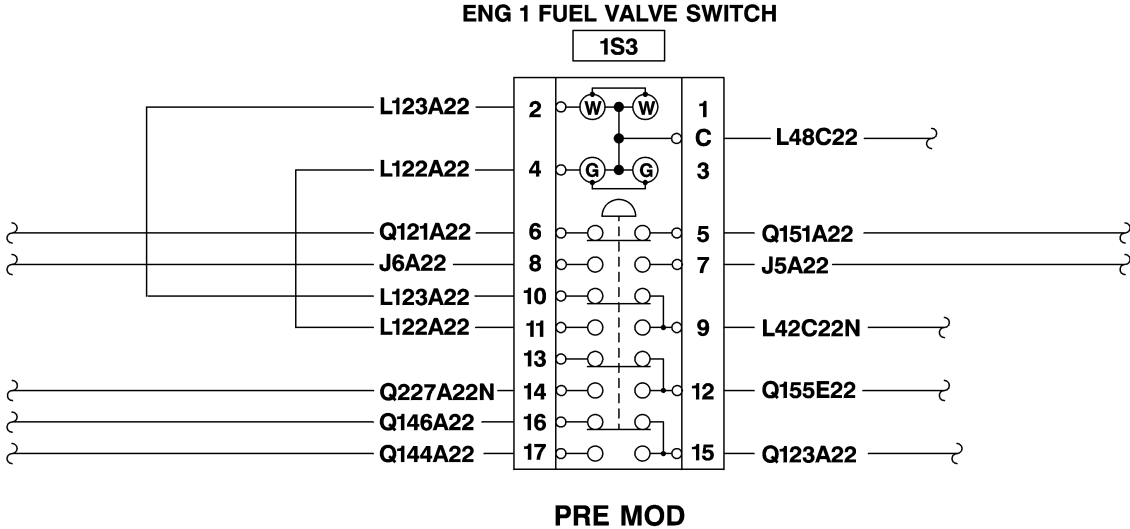
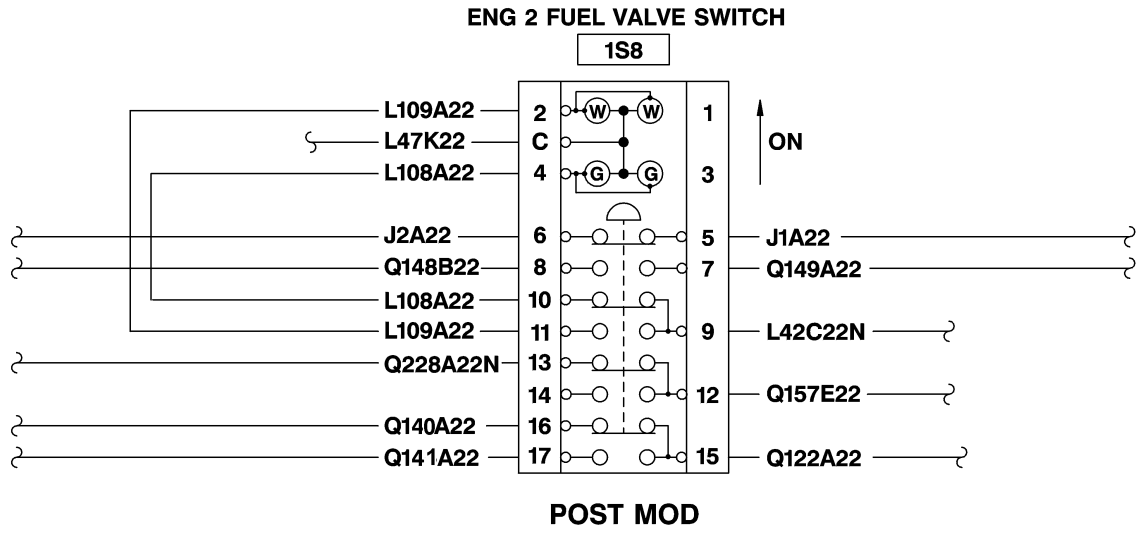
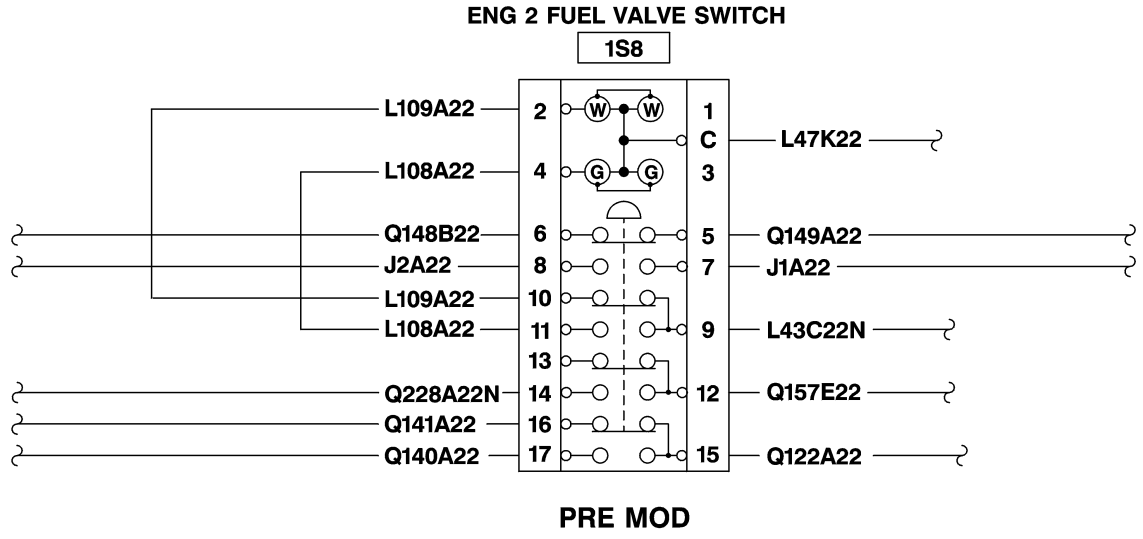

Figure 2
Switch Termination Schematic



03536001

Figure 3
No.1 Fuel Valve Switch Wiring Diagram



03536002

Figure 4
No.2 Fuel Valve Switch Wiring Diagram