

TECHNICAL BULLETIN
Bell Helicopter **TEXTRON**

A Subsidiary of Textron Inc.

No. 230-02-33

Date 03-25-02

Page 1 of 7

DATE
REV

MODEL AFFECTED: 230

SUBJECT: TRANSMISSION TOP CASE BUSHINGS P/N 222-040-326-101, REPLACEMENT OF

HELICOPTERS AFFECTED: Model 230 helicopters serial number 23001 through 23038.

COMPLIANCE: As required

DESCRIPTION:

Every 600 hours of operation, transmission top case bushings P/N 222-040-326-101 must be inspected for wear. These bushings are installed in the forward lug of the transmission top case P/N 222-040-061-105. When the bushings are worn beyond damage limits they must be replaced.

This bulletin introduces bushing replacement procedure, which can be accomplished with the transmission installed in the aircraft.

APPROVAL:

Not required

MANPOWER:

Approximately 6.0 man-hours are required to complete this bulletin. Man-hours are based on hands-on time, and may vary with personnel and facilities available.

MATERIALS:

Required Material:

The following material is required for the accomplishment of this bulletin and may be obtained through your Bell Helicopter Textron Supply Center.

<u>Part Number</u>	<u>Nomenclature</u>	<u>Quantity</u>
222-040-326-101	Bushing	A/R

Consumable Material:

The following material is required to accomplish this bulletin, however this material is considered consumable (bench stock) material and may not require ordering depending on the operators consumable material stock levels. This material may be obtained through your Bell Helicopter Textron Supply Center.

<u>Part Number</u>	<u>Nomenclature</u>	<u>Quantity</u>	<u>Reference</u>
MILP23377TY1CL2 2OZ	Primer, Epoxy	A/R	C-204

SPECIAL TOOLS:

T103416-101 Tool Set (Note 1)

Tool Set T103416-101 includes the following details:

T103416-103, which includes:

T103416-105	Mandrel
T103416-107	Receptacle
AN960-616	Washer
MS16998-80	Bolt
T103416-109	Pull bolt
T103416-111	Reamer
T103416-113	Cutter

Note 1: Tool set may be purchased from your Bell Helicopter Supply Center. It may also be rented from Bell CPR Department.

WEIGHT AND BALANCE:

Not affected

ELECTRICAL LOAD DATA:

Not affected

REFERENCES:

BHT-230-MM-5 and 6

PUBLICATIONS AFFECTED:

BHT-230-CR&O-2

ACCOMPLISHMENT INSTRUCTIONS:

This procedure details the replacement of the P/N 222-040-326-101 sleeve bushings (Figure 1) installed in the top case assembly, P/N 222-040-061-105.

1. Gain access to the transmission top case idler link lugs by disconnecting the P/N 222-010-409-105 idler link assembly. Refer to BHT-230-MM-6.

-NOTE-

The flanged bushings P/N 222-040-255-101 installed in the inner lugs of the top case **are not replaceable in the field.**

2. Remove the existing sleeve bushing using the P/N T103416-103 replacement set as shown in Figure 2, Detail A.
3. Visually inspect the lug for obvious damage. Bushing hole should measure 1.063 inches maximum. Do a Liquid penetrant Inspection of the hole per BHT-ALL-SPM.
4. Install new sleeve bushing as follows:

-NOTE-

Apply unreduced polyamide epoxy primer C-204 to bushing O.D. just prior to bushing installation.

CAUTION

Do not exceed 275° F temperature if heating of the transmission case is required.

- a. Thermo fit new bushing P/N 222-040-326-101 into the lug per BHT-ALL-SPM using P/N T103416-103 replacement set as shown in Figure 2, Detail B.
- b. Install the bushing .000 - .005 inches below the inboard surface face of the lug as noted in Figure 1. Allow primer to dry.

-NOTE-

It may be necessary to remove the forward left-hand pylon attach fitting, P/N 222-031-615-101, prior to reaming the left-hand idler link attach lug bushing. If this becomes necessary, refer to BHT-230 CR&O-2 Manual, Chapter 63 for removal instructions. Use pull bolt, P/N T103416-109, to aid in removal of the pylon attach fitting.

-NOTE-

Make sure the guide portion of the cutter and reamer receives lubrication oil during the cut and ream operation.

CAUTION

Absolutely assure that bushing P/N 222-040-326-101 does not turn during the cut and ream operation. If the bushing turns, remove bushing from top case and inspect the lug for galling, tearing and scratches. If galling, tearing or scratching occurred, remove top case from service. If lug I.D. does not have galling, tearing or scratches, start again with step 4a.

5. Using the three flute straight shank cutter, P/N T103416-113, slowly make one cut through the bushing. Use a suitable lightweight lubricating oil to assure a smooth cut. Refer to Figure 3, Detail 3A.
6. Remove the cutter, clean the bushing bore, removing any metal chips or shaving.
7. Final ream bushing(s) to 0.8750-0.8754 inch using the left-hand helical 8-flute hand reamer, P/N T103416-111. Use a suitable lightweight lubricating oil to assure a smooth cut. Refer to Figure 3, Detail 3B.
8. Remove the cutter and clean the bushing bore, removing any metal chips or shaving.
9. Inspect bushing I.D. in three places. Dimensions must be 0.8750-0.8754 inch.
10. Install all parts previously removed and reconnect idler link assembly P/N 222-010-409-105. Refer to BHT-230-MM-6.
11. Annotate aircraft records to reflect compliance with this bulletin.

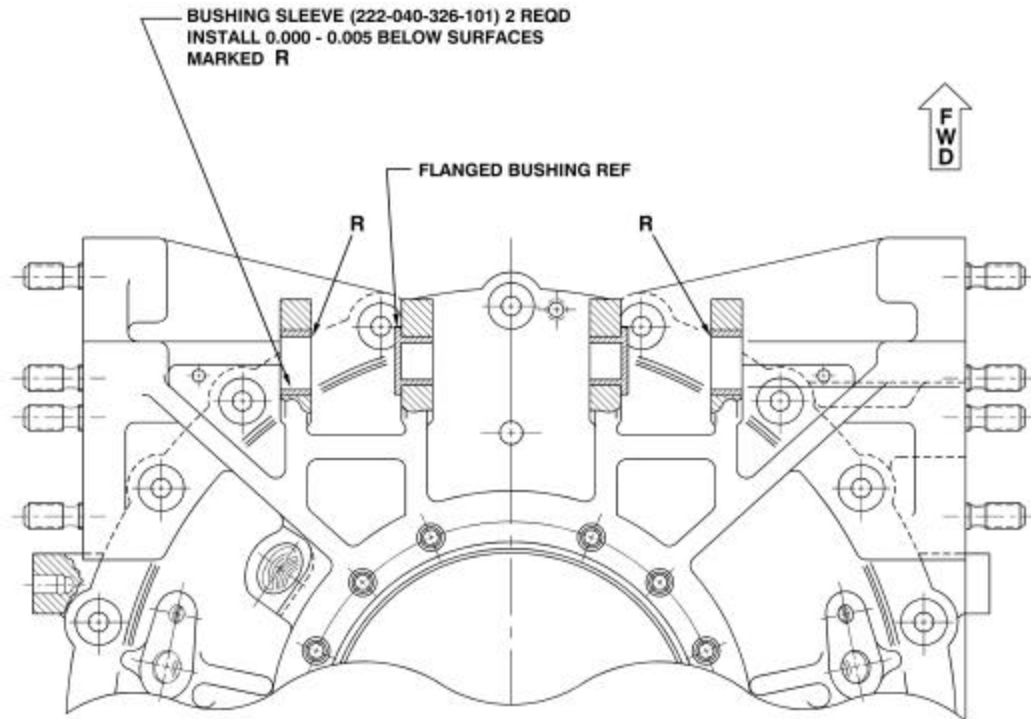

TRANSMISSION TOP CASE (222-040-061)
VIEW LOOKING DOWN

FIGURE 1
TRANSMISSION TOP CASE

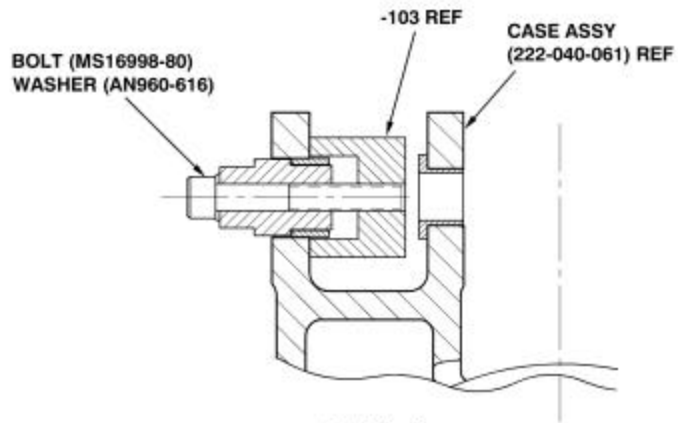

DETAIL A
BUSHING REMOVAL

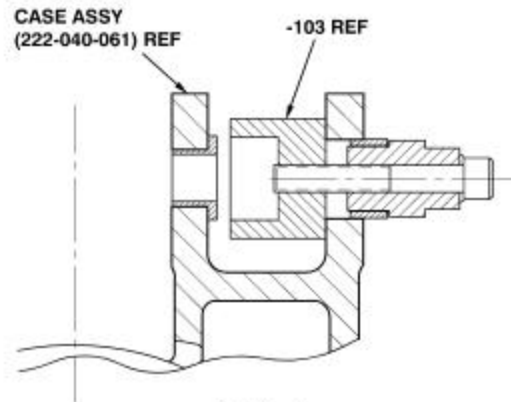

DETAIL B
BUSHING INSTALLATION

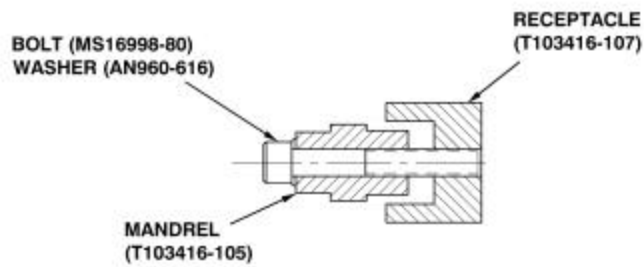

DETAIL C
DETAIL OF REPLACEMENT SET (T103416-103)

01633002

FIGURE 2
BUSHING REMOVAL / INSTALLATION

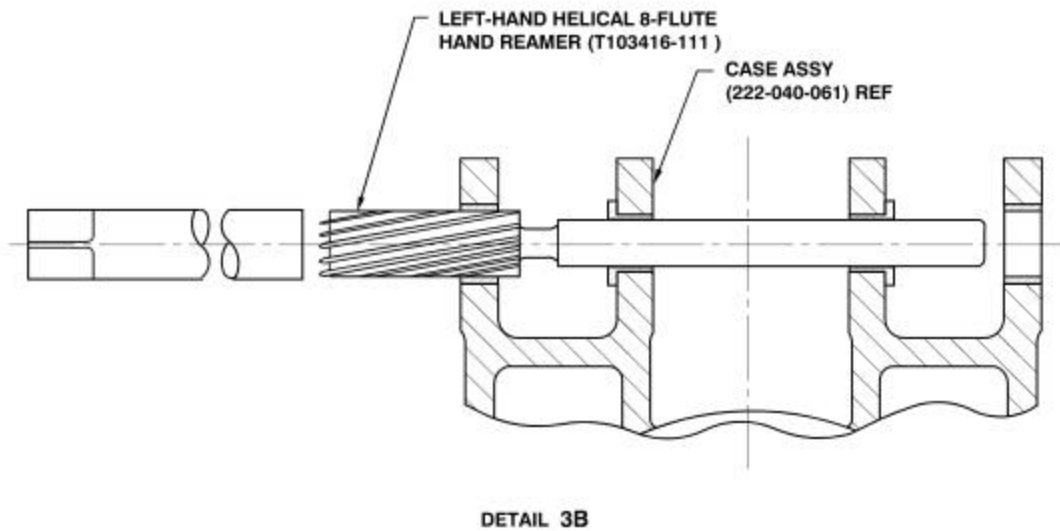
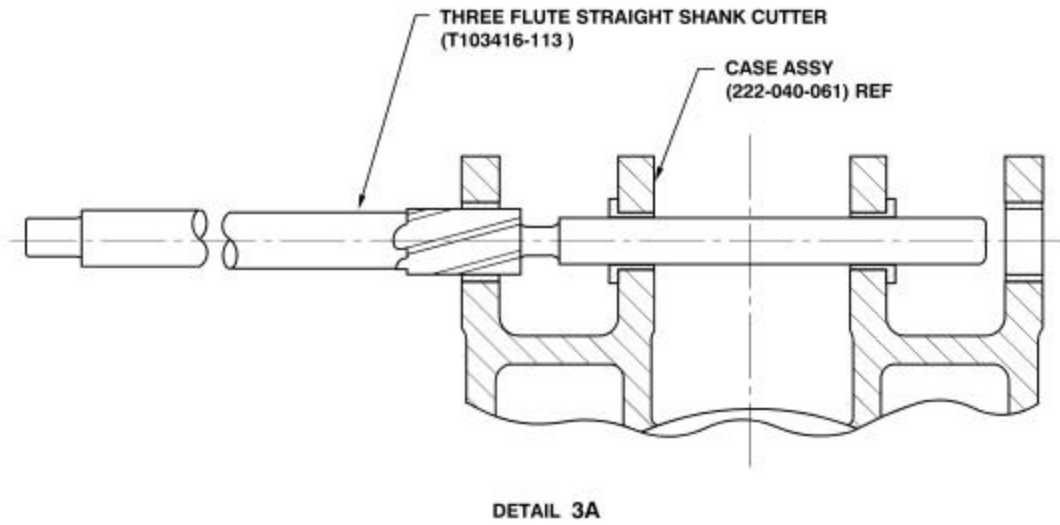

01633003

FIGURE 3
TOOL APPLICATION