

**TECHNICAL BULLETIN**  
**Bell Helicopter** **TEXTRON**

A Subsidiary of Textron Inc.

No. 407-04-57

Date March 16, 2004

Page 1 of 3

DATE
REV

**MODEL AFFECTED:** 407

**SUBJECT:** MAST ASSEMBLY 407-040-011-ALL, BUILT UP  
PROCEDURE CHANGE OF

**HELICOPTERS AFFECTED:** Model 407 Helicopters

**COMPLIANCE:** At Customer's Option

**DESCRIPTION:**

Bell helicopter has received report that bearing mast nuts p/n 406-040-090-103 were found loose during the overhaul inspection. Investigation has revealed that increasing the torque value would result in a tighter joint ensure that correct torque would be maintained.

This Technical Bulletin introduces changes to bearing installation procedure and the torque value for the mast bearing nut 406-040-090-103.

**APPROVAL:**

The engineering design aspects of this bulletin are Transport Canada approved.

**MANPOWER:**

No additional man-hours are required to accomplish this bulletin.

**MATERIALS:**

Not required

**SPECIAL TOOLS:**

None required

**ELECTRICAL LOAD DATA:**

Not affected

**REFERENCES:**

BHT-407-CR&O, Rev. 1, 15 December 1997

Chapter 63-10, Drive System Mast

**PUBLICATIONS AFFECTED:**

BHT-407-CR&O, Rev. 1, 15 December 1997

Chapter 63-10, Drive System Mast

**ACCOMPLISHMENT INSTRUCTIONS:**

1. During the build up of the mast assembly, follow the procedures in the BHT-407-CR&O, Chapter 63-10, with the following changes:
  - a. Immediately after the installation of the mast bearing and the liner on the mast assembly, apply pressure on the bearing inner races as shown on Figure 1.
  - b. At the installation of the mast nut apply a torque of 600 to 660 FT-LBS.
2. Make an entry in the Mast assembly Historical Service Record to show that this Technical Bulletin has been completed.

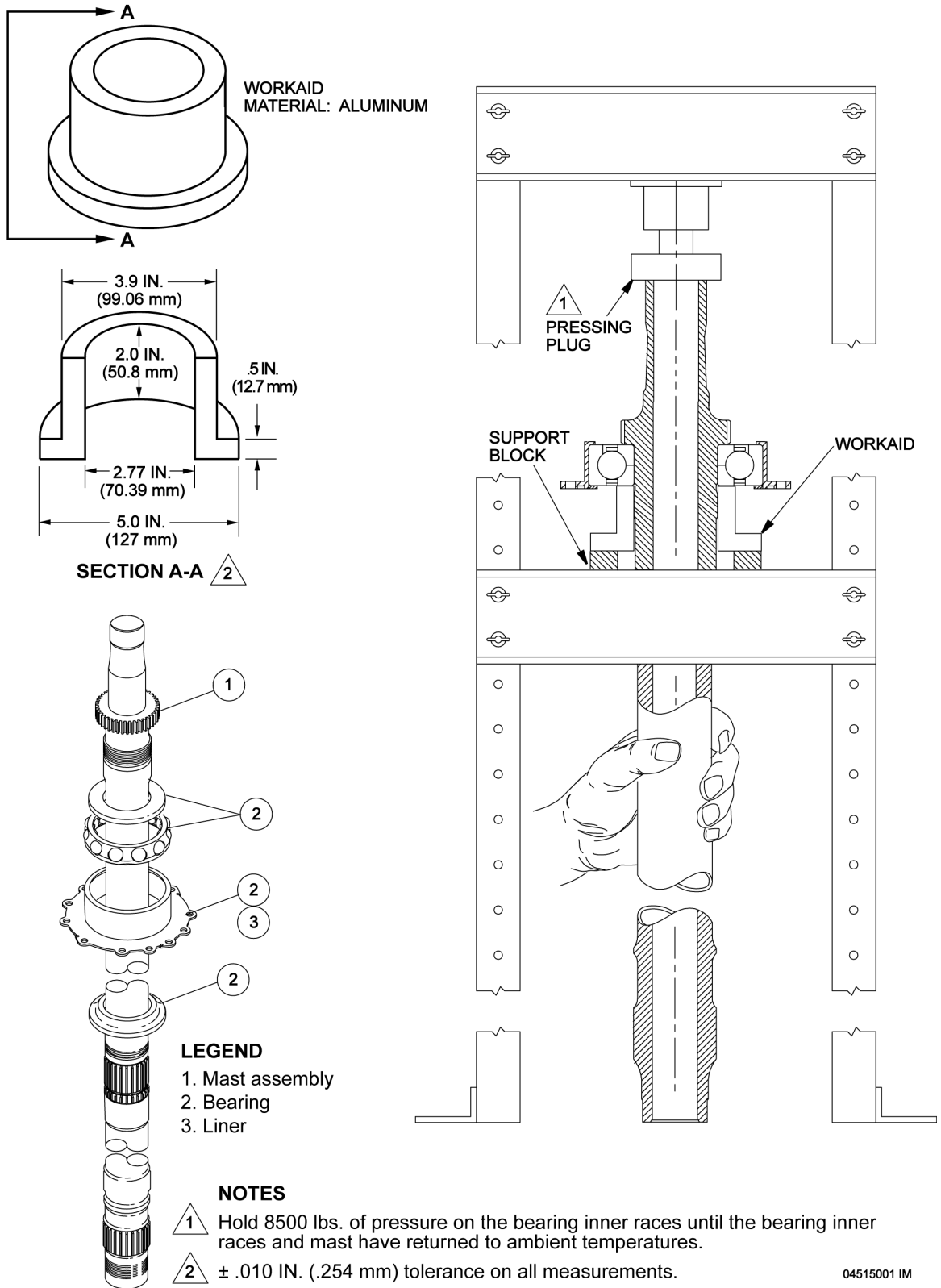

**Figure 1. Bearing inner races installation**