

TECHNICAL BULLETIN
Bell Helicopter **TEXTRON**

A Subsidiary of Textron Inc.

No. 407-05-63

Date Feb 22, 2005

Page 1 of 10

DATE
REV

MODEL AFFECTED: 407

SUBJECT: ROTOR BRAKE MODIFICATION KIT 407-704-022-101, INSTALLATION OF,

HELICOPTERS AFFECTED: Model 407 helicopters serial numbers 53000 through 53631 that have Installation Instruction BHT-407-II-8 incorporated.

[Model 407 helicopters serial number 53632 and subsequent that have Installation Instruction BHT-407-II-8 incorporated will have the intent of this bulletin accomplished prior to delivery]

COMPLIANCE: At Customer's Option

DESCRIPTION:

It has been determined that wear observed on the rotor brake caliper pads and attaching hardware will reduce when caliper have additional support. Bell Helicopter has developed a rotor brake modification kit that will stabilize the calipers and minimize damage caused by vibration.

Ship serial number 53000 through 53443 shall have Installation Instruction BHT-407-II-30 completed prior to the accomplishment of this bulletin.

Part I of this bulletin has you prepare the helicopter for maintenance.

Part II of this bulletin has you determine the condition of the rotor brake caliper.

Part III of this bulletin gives the installation instruction for the rotor brake modification kit.

APPROVAL:

The engineering design aspects of this bulletin are TCCA approved.

MANPOWER:

Approximately 6 man-hours are required to complete this bulletin. Man-hours are based on hands-on time, and may vary with personnel and facilities available.

WARRANTY:

Owner / Operators of model 407 helicopter's who comply with the instructions outlined in this Technical Bulletin will receive a special warranty credit of 100% towards the purchase of the kit **407-704-022-101** only (parts listed in the "Required Material" section of this Technical Bulletin).

To receive this credit:

Purchase the required material from an approved BHTI supply source. Order the kit P/N **407-704-022-101** no later than 31 August, 2005. Submit a completed MMIR to BHTI Warranty no later than 30 days after the receipt of the kit.

MATERIALS:

Required Material:

The following material is required for the accomplishment of this bulletin and may be obtained through your Bell Helicopter Textron Supply Center. Order kit **407-704-022-101** that consists of the following parts:

<u>Part Number</u>	<u>Nomenclature</u>	<u>Quantity</u>
407-040-341-101	Bracket Assembly	1
407-040-342-101	Bracket Assembly	1
407-040-343-101	Bracket Assembly	2
407-040-344-101	Turnbuckle	2
AN310-5	Nut	4
AN5H34	Bolt	4
MS21042L4	Nut	10
MS24665-229	Cotterpin	4
MS9501-15	Bolt	2
MS9501-20	Bolt	2
NAS1149C0532R	Washer	8
NAS1149D0463K	Washer	8
NAS1149F0463P	Washer	14
NAS1193E4CP	Locking Device	2

NAS1423-4	Jam Nut	2
NAS1423-4LH	Jam Nut	2
NAS6604H9	Bolt	4
MB-4M-41	Bearing, Rod End	2
MM-4M-40	Bearing, Rod End	2
60-015-1	Gasket	2

SPECIAL TOOLS:

None required

WEIGHT AND BALANCE:

<u>Weight</u>	<u>Arm</u>	<u>Longitudinal Moment</u>	<u>Arm</u>	<u>Lateral* Moment</u>
+0.80 Lbs (+0.40 kg)	150.5 in. (3823 mm)	+120 in-Lbs (+15.3 kg x mm/100)	0.0 in. (0.0 mm)	0.0 in-Lbs (0.0 kg x mm/100)

* In lateral calculations, - is left and + is right.

ELECTRICAL LOAD DATA:

Not affected

REFERENCES:

BHT-407-II-30, Installation Instruction for Drive Train Modification

BHT-407-II-8, Installation Instruction for Rotor brake Kit (Dual Caliper)

BHT-407-IPB, Rev. 2, 01 May 2002. Chapter 63, Figures 16 and 17

BHT-407-MM, Rev. 18, 29 Aug 2003. Chapter 63, Section 63-97

BHT-407-MM, Rev. 16, 07 Jun 2002. Chapter 96, Section 96-209

Technical Bulletin 407-02-36

Northwest Dynamics Maintenance and Overhaul Manual B0223-0M
(attached to T.B. 407-02-36)

-NOTE-

You can get additional copies of this manual from BHT Product Support Engineering at the numbers that follow:

Tel: 450-971-6407
Tel: 1-800-243-6407 (Continental USA)
Tel: 1-800-361-9305 (within Canada)
Fax: 450-433-0272
E-mail: pselight@bellhelicopter.textron.com

PUBLICATIONS AFFECTED:

BHT-407-MM, Rev. 18, 29 Aug 2003. Chapter 63, Section 63-97

BHT-407-IPB, Rev. 2, 01 May 2002. Chapter 63, Figures 16 and 17

BHT-407-II-8, Installation Instruction for Rotor brake Kit (Dual Caliper)

ACCOMPLISHMENT INSTRUCTIONS:

PART I – Preparation of Helicopter

1. Remove transmission fairing assembly and air intake cowling assembly (BHT-407-MM-5, Chapter 53).
2. Remove forward firewall drive shaft upper and lower cover assembly (BHT-407-MM-5, Chapter 53).
3. Gain access to forward R/H and L/H side of engine gearbox assembly.
4. Remove fuel filter from forward firewall (BHT-407-MM-4, Chapter 28).
5. Disconnect R/H engine gearbox chip detector to gain access to R/H gearbox accessory pad (BHT-407-MM, Chapter 96).

PART II – Caliper Inspection

1. Reference Northwest Dynamics Maintenance and Overhaul Manual B0223-0M. Inspect caliper guide bolts and friction pad assembly for condition.

2. If calipers are damaged, repair in accordance with Northwest Dynamics Maintenance and Overhaul Manual B0223-0M.
3. If calipers are not damaged, go to Part III.

PART III – Rotor Brake Kit Installation

-NOTE-

Ensure correct orientation of brackets for installation of rod end and turnbuckle.

1. Remove & discard cover plate (1, Figure 1, sheet 1) and gasket (2) from R/H and L/H engine gearbox accessory pad. Install new gasket (3) and bracket (4), (5) with washer (6) and nut (7). Torque T_1 50 to 70 IN-LBS (5.65 to 7.90 Nm).



CAUTION

DO NOT SPLIT CALIPER ASSEMBLY. IF BOLTS ARE CHANGED ONE AT A TIME, NO BLEEDING IS REQUIRED. INSTRUCTIONS PROVIDED IN PART III OF TECHNICAL BULLETIN 407-02-36.

2. Remove cotter pin, nut (8) and washers (9), (10) from caliper assembly. Carefully remove bolt (11) and washer (12). Discard bolt (11), nut (8), washers (10), (12) and cotter pins.
3. Position bracket (13) on caliper assembly.
4. Install washer (15) on new bolt (14). Carefully install thru caliper and bracket (13) with washers (15), (9) and new nut (16). Torque T_2 100 to 150 IN-LBS (11.30 to 16.95 Nm). Secure with cotter pin (17).
5. Safety  bolt head (14) with guide pin bolthead (26) as per view A of Figure 1, sheet 2.
6. Repeat items 2 to 5 for remaining caliper hardware.
7. Combine the turnbuckle (18), nuts (19), (20), locking device (21) and rod ends (22), (23). Reference Detail A for locking device installation.

-NOTE-

The turnbuckle must be installed with zero pre-load, indicated by bolts slipping easily thru uniballs and engaging the bracket insert threads. Reference items (4), (5) and (13) from Figure 1, sheet 1.

8. Install turnbuckle assembly on brackets with bolts (25) and washers (24). Torque bolts (25), nut (19) and nut (20)  50 to 70 IN-LBS (5.65 to 7.90 Nm) .
9. Safety  bolt head (25), nut (19) and nut (20). Refer to Figure 1, sheet 1, 3 and 4.
10. Repeat steps 7 and 8 for opposite side.
11. Return the aircraft to flight status (reverse of Part I)
12. Make an entry in the helicopter historical records to show that you have completed this installation.
13. Make an entry in the record of the Technical Bulletins in the Illustrated Parts Breakdown and the Maintenance Manual.

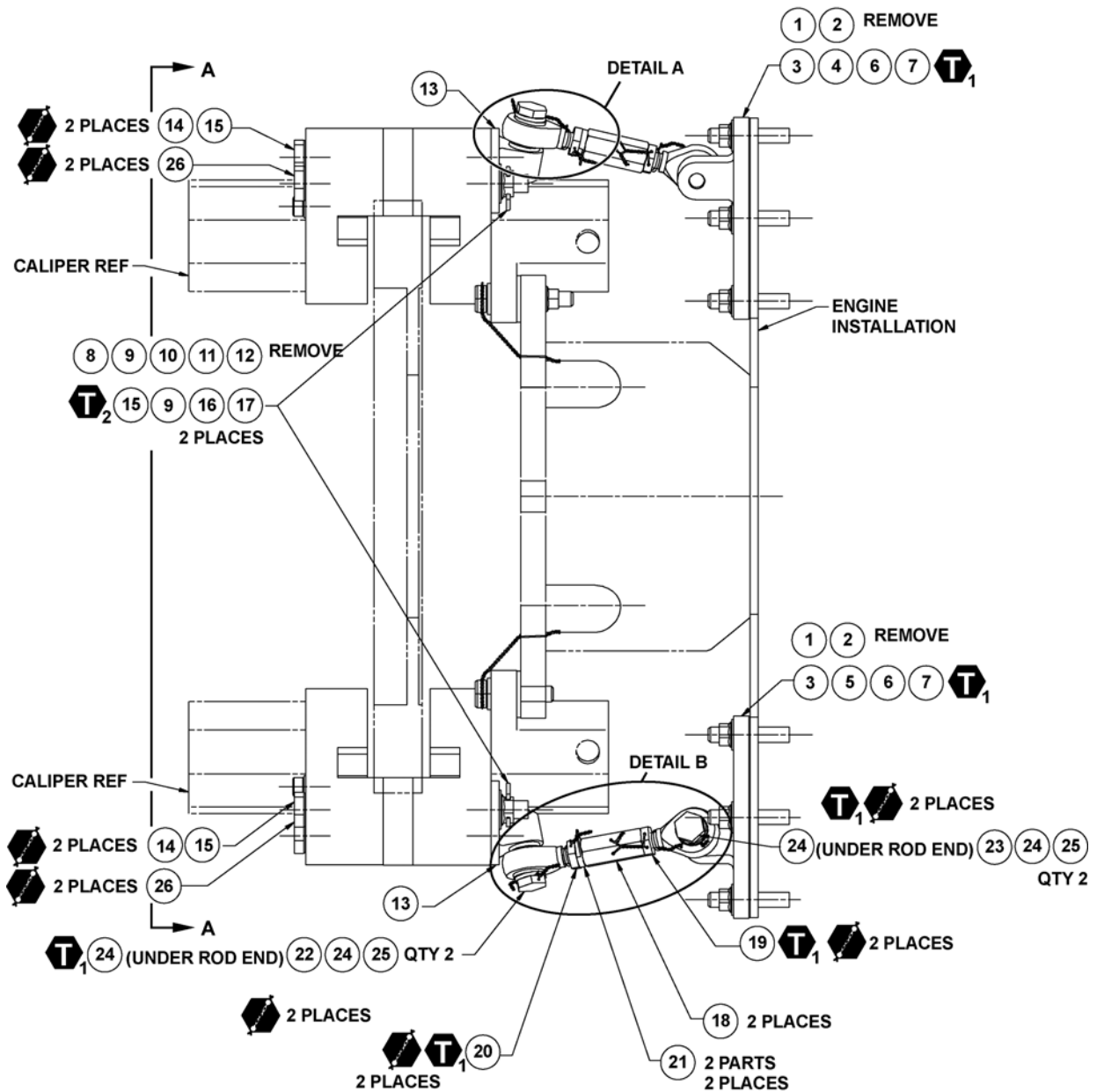

LEGEND:

- | | | |
|---------------------------------|-----------------------------|--------------------------------|
| 1. Cover Plate (Remove) | 10. Washer (Remove) | 18. 407-040-344-101 Turnbuckle |
| 2. Gasket (Remove) | 11. Bolt (Remove) | 19. NAS1423-4LH |
| 3. 60-015-1 Gasket | 12. Washer (Remove) | 20. NAS1423-4 Nut |
| 4. 407-040-342-101 Bracket R/H | 13. 407-040-343-101 Bracket | 21. NAS1149E4CP Locking Device |
| 5. 407-040-341-101 Bracket L/H | 14. AN5H34 Bolt | 22. MM-4M-40 Rod End |
| 6. NAS1149D0463K Washer 4 req'd | 15. NAS1149C0532R Washer | 23. MB-4M-41 Rod End |
| 7. MS21042L4 Nut 4 req'd | 16. AN310-5 Nut | 24. NAS1149F0463 Washer |
| 8. Nut (Remove) | 17. MS24665-229 Cotter Pin | 25. NAS6604H9 Bolt |
| 9. B11870 Washer (Reuse) | | 26. D0164-1 Guide Pin |

T₁ 50 TO 70 IN-LBS
(5.65 TO 7.90 Nm)

T₂ 100 TO 150 IN-LBS
(11.30 TO 16.95 Nm)

LOCKWIRE
AS100028

04572001_IM

Figure 1: Rotor Brake Mod Kit (sheet 1 of 4)

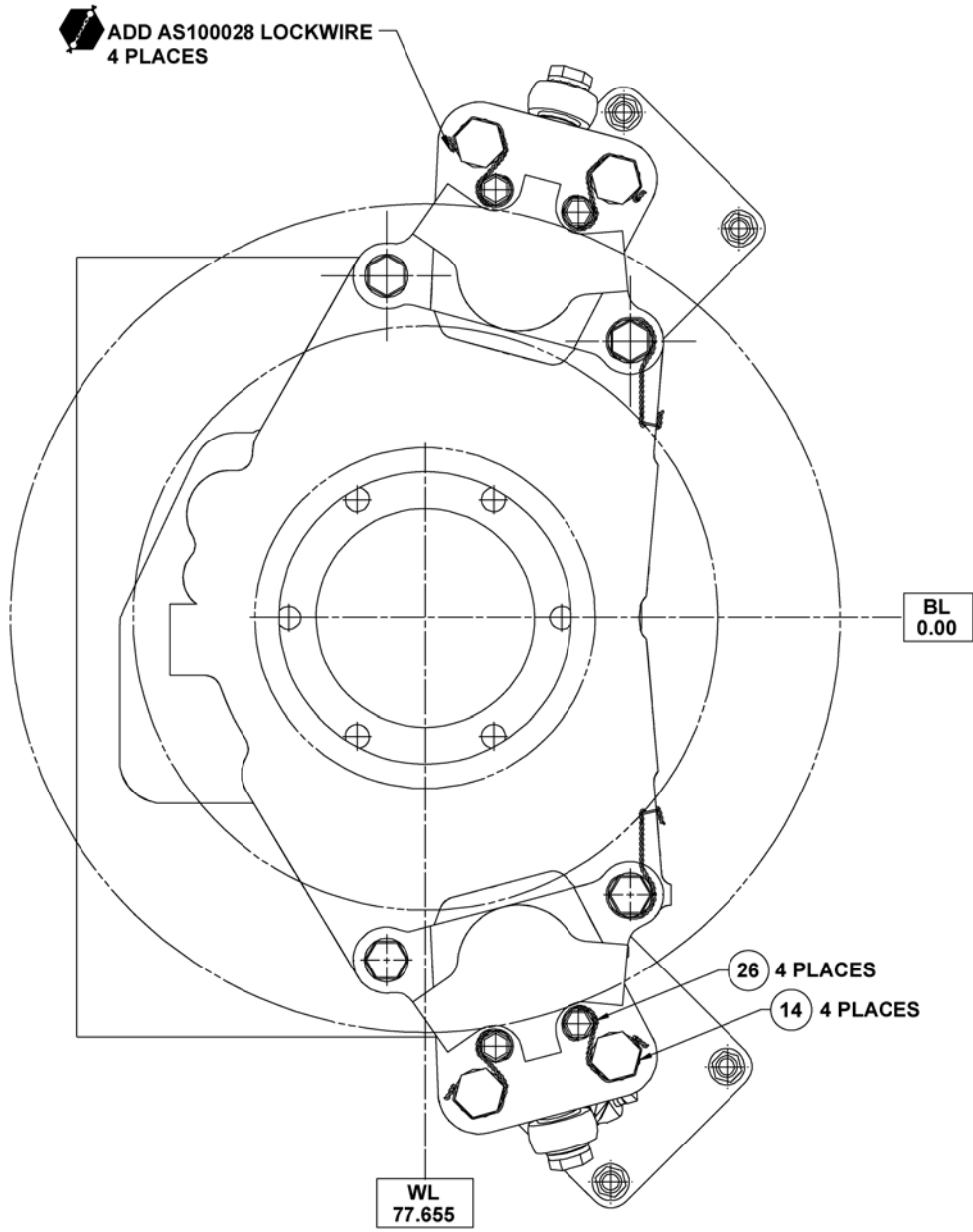

VIEW A - LOOKING AFT
LOCKWIRE, CALIPER BOLTS
ROTATED 90° CW

04572002_im

Figure 1: Rotor Brake Mod Kit (sheet 2)

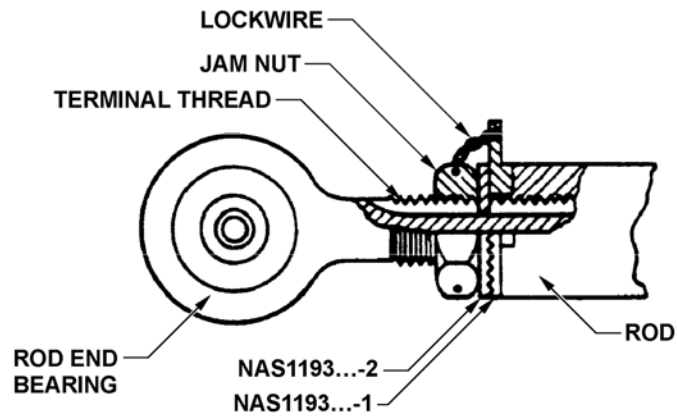
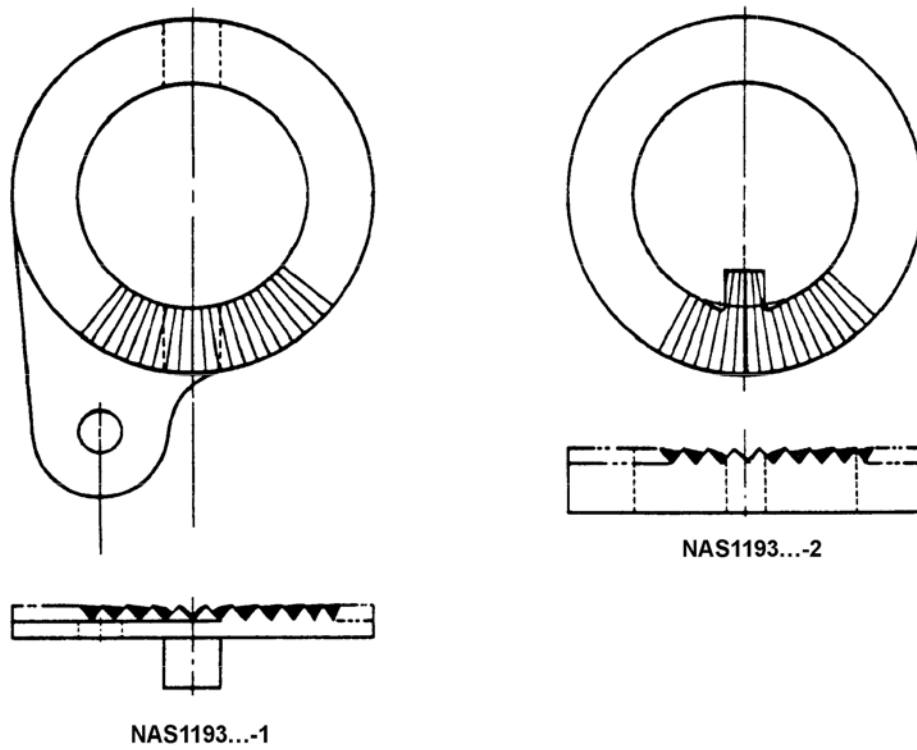

04572003

Figure 1: Rotor Brake Mod Kit (sheet 3)

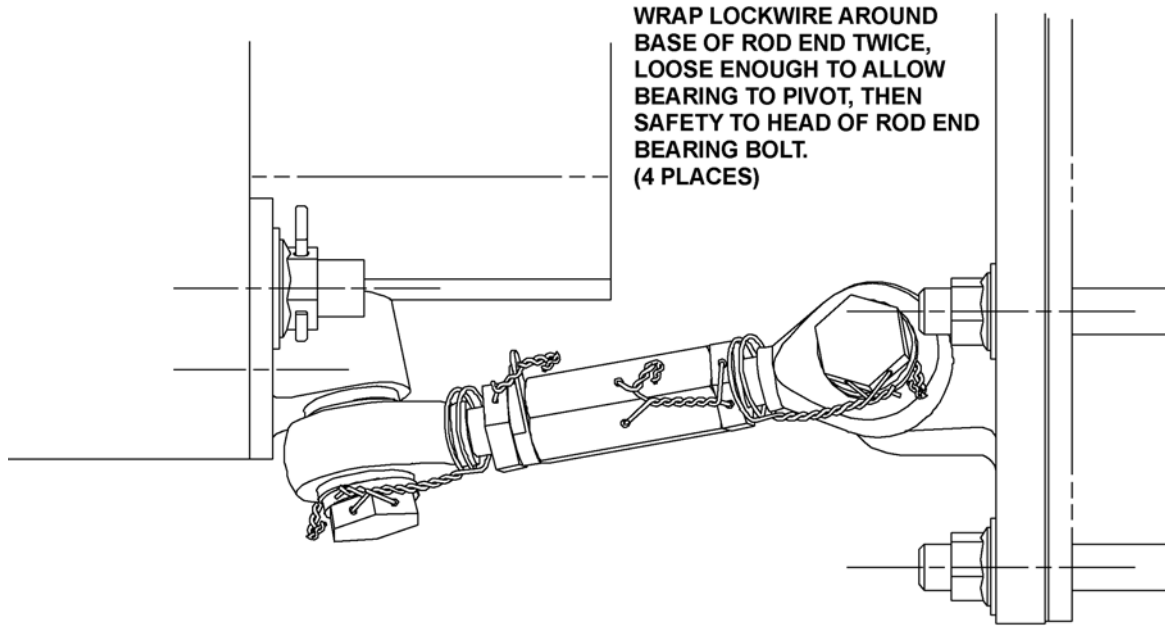

DETAIL B
INSTALLATION OF LOCKWIRE ON TURNBUCKLE

04572004

Figure 1: Rotor Brake Mod Kit (sheet 4)