

TECHNICAL BULLETIN
Bell Helicopter **TEXTRON**
A Subsidiary of Textron Inc.

NO 407-99-14

DATE 2-5-99

PAGE NO. 1 of 6

DATE
REV.

MODELS AFFECTED: 407

SUBJECT: **IMPROVED FRAHM DAMPER ASSEMBLY
407-010-150-105A, INTRODUCTION OF.**

HELICOPTERS AFFECTED: 407, Serial Numbers 53000 through 53199

[Helicopters Serial Number 53200 and subsequent will have the intent of this Technical Bulletin completed before delivery].

COMPLIANCE: At the option of the customer.

DESCRIPTION:

Bell Helicopter has been told that the quality of the ride degrades on some model 407 helicopters. This degradation can be caused by the rotation of the springs inside the FRAHM Damper assembly, 407-010-150-103A.

PART I of this bulletin introduces a new FRAHM damper assembly, 407-010-150-105A, that includes a spring anti-rotation feature.

PART II of this bulletin introduces a dynamic tuning procedure for the FRAHM damper assembly, 407-010-150-105A, that can be done on the aircraft.

APPROVAL:

The engineering design aspects of this Technical Bulletin are Transport Canada approved.

MANPOWER:

Approximately 1.0 man-hour is necessary to complete PART I of this Bulletin. Man-hours are based on hands-on time and can change due to the personnel and the facilities available. The FRAHM damper dynamic tuning (PART II) is not included in the estimate.

7851 60540

SPECIAL PRICING:

Owners/operators of 407 helicopters who comply with the instructions outlined in this bulletin are eligible for a special price of US \$19,900 for the new FRAHM 407-010-150-105A. This offer is limited to one (1) FRAHM per eligible helicopter.

To receive this special price:

1. Customers must order the new FRAHM 407-010-150-105A from an approved BHT spares supply source.
2. Comply with the instructions outlined in this bulletin no later than 31 December 1999.
3. The owner/operator must make sure to specify he is completing this Technical Bulletin. You will be asked to give the serial number of the helicopter on which the FRAHM will be installed.

- NOTE -

Customers who comply with the instructions in this bulletin after 31 December 1999 are not eligible for the special pricing provisions listed above.

MATERIAL:

Required Material:

The material that follows is necessary to complete this Technical Bulletin and can be procured through your Bell Helicopter Textron Supply Center.

PART I

<u>PART NUMBER</u>	<u>NOMENCLATURE</u>	<u>QUANTITY</u>
407-010-150-105A	FRAHM DAMPER	1

Consumable Material:

The material that follows is necessary to complete this Bulletin, however, this material is consumable (bench stock) material and does not require ordering depending on the operators consumable material stock levels. This material can be obtained through your Bell Helicopter Textron supply Center.

<u>PART NUMBER</u>	<u>NOMENCLATURE</u>	<u>REF.NO.</u>
MIL-C-16173,GR1 2OZ	CORROSION PREVENTIVE COMPOUND	C-101
MIL-C-16173,GR2 6OZ	CORROSION PREVENTIVE COMPOUND	C-104

SPECIAL TOOLS:

None required.

WEIGHT AND BALANCE:

Not affected.

ELECTRICAL LOAD DATA:

Not affected.

REFERENCES:

BHT-407-MM-2, Rev.2, 24 October, 1996

Chapter 18, Rotor Track and Balance.

BHT-407-MM-6, Rev. 2, 1 June, 1996

Chapter 62, Main Rotor System.

PUBLICATIONS AFFECTED:

BHT-407-MM-2, Rev. 2, 24 October, 1996

Chapter 18, Rotor Track and Balance.

BHT-407-MM-6, Rev. 2, 1 June, 1996

Chapter 62, Main Rotor System.

BHT-407-IPB, Rev. 3, 22 February, 1996

Chapter 62, Main Rotor System.

ACCOMPLISHMENT INSTRUCTIONS:

PART I - Replacement of FRAHM Damper

1. Remove the cover and the FRAHM damper assembly (refer to BHT-407-6, Chapter 62).
2. Install the new FRAHM damper and the cover assembly removed in Step 1 (refer to BHT-407-6, Chapter 62).

PART II - FRAHM Damper Tuning Procedure

1. Install the vibration measuring equipment for the main rotor Track and Balance (refer to BHT-407-6, Chapter 18).
2. Decrease the main rotor 1/rev down to a maximum of 0.25 to 0.30 ips at this time.

- NOTE -



The maximum 4/rev's limit levels vertical forward (V-Fwd) is (0.38 ips) and the vertical aft (V-Aft) is (0.25 ips) in the hover, 60, 100, 120 knots and letdown.

3. Review the 4/rev data in the hover and at the forward airspeeds of 60 knots, 100 knots, 120 knots and letdown.

- NOTE -

If the measured 4/rev vibration levels are greater than 0.50 ips, remove the weights from the tuning weight stock in 0.22 lb (100 grams) increments. If the vibration level is below 0.50 ips, remove the weights in 0.11 lb (49.90 grams) increments until the vibration criteria are met. (Refer to the Table 1 for the FRAHM WEIGHTS and the part numbers.)

4. Remove the FRAHM damper cover (2, Figure 1).
5. Get access to the FRAHM damper tuning weights (6 to 11). Do not remove the FRAHM damper plate (3).

6. Remove the nut (4) and the washers (5). Remove the weights from the tuning weight stock (the weights are to be removed in pairs).
7. Install the washer (5) and nuts (4) .
8. Attach the FRAHM damper cover (2) with the screws (1) .
9. Repeat the Steps (4 thru 8) until the 4/rev limits are attained.
10. Tune the 1/rev vibration levels to the prescribed limits (refer to BHT-407-MM-2, Chapter 18).

- NOTE -

It is permitted to add or remove the tuning stock weights to the FRAHM damper assembly to achieve the acceptable 4/rev vibration limits. However, in most cases you will need to remove weight.

TABLE 1 - FRAHM Damper Weights

PART NO.	ITEM	THICKNESS	MATERIAL	WEIGHT IN PAIRS (GRAMS)
407-010-161-101	Weight	0.125	Cres.	Approx. 137 grams
407-010-161-103	Weight	0.125	AL ALY	Approx. 50 grams
407-010-161-105	Weight	0.125	Tungsten	Approx. 317 grams
407-010-161-107	Weight	0.250	Cres.	Approx. 285 grams
407-010-161-109	Weight	0.250	AL ALY	Approx. 100 grams
407-010-161-111	Weight	0.250	Tungsten	Approx. 613 grams

- NOTE -

The tuning weights must be used in pairs to provide a symmetrical configuration about the center of rotation.

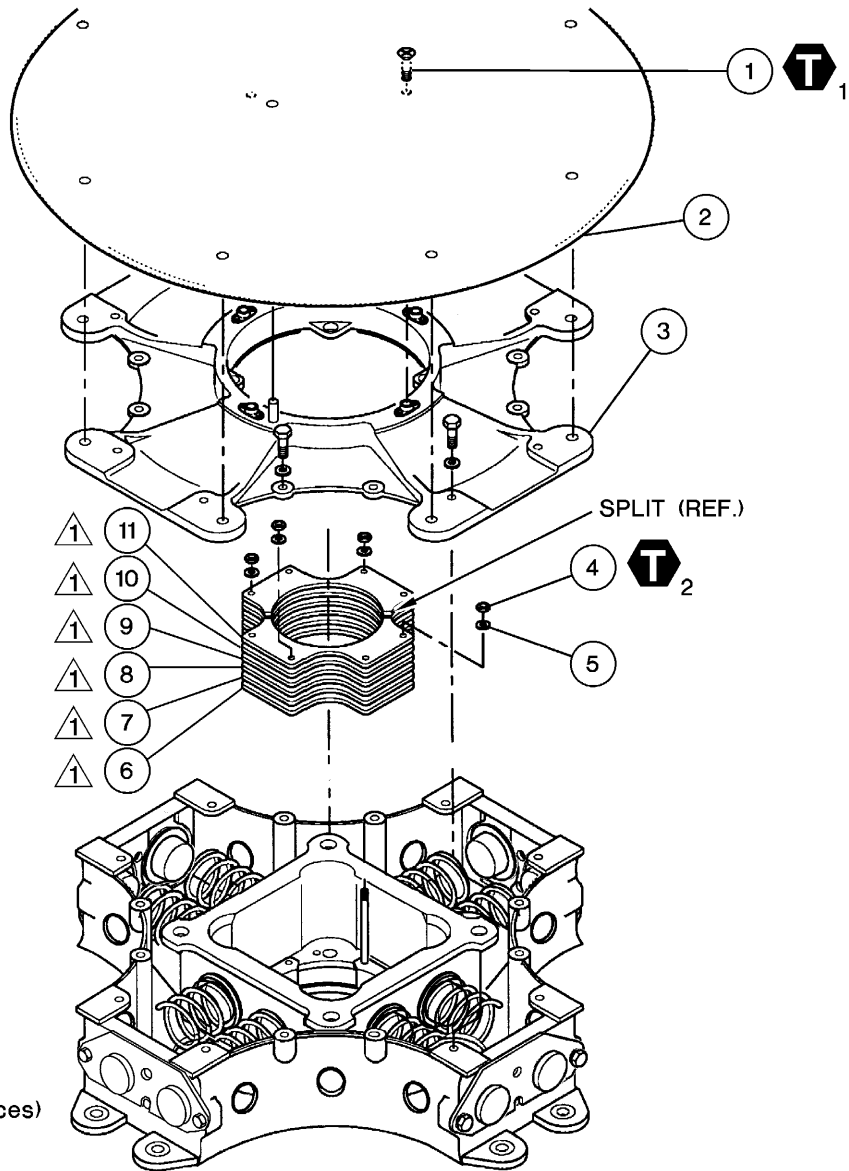

LEGEND

- 1. Screw
- 2. FRAHM damper cover
- 3. FRAHM damper plate
- 4. Nut (Typical 4 places)
- 5. Washer (Typical 4 places)
- 6. Tuning weight
- 7. Tuning weight
- 8. Tuning weight
- 9. Tuning weight
- 10. Tuning weight
- 11. Tuning weight

T₁ 140 IN-LBS
 (15.8 Nm)

T₂ 60 TO 80 IN-LBS
 (6.8 TO 9.0 Nm)

NOTES

- 1** Alternate the split lines for weights by 90° from one row to another.
- 2** Refer to Table 1 for FRAHM damper weights information.

Figure 1. FRAHM Damper Tuning