

**TECHNICAL BULLETIN**  
**Bell Helicopter** **TEXTRON**

A Subsidiary of Textron Inc.

No. 412-05-201

Date May 11, 2005

Page 1 of 7

DATE
REV

**MODEL AFFECTED:** 412 / 412EP

**SUBJECT:** Bearing and Liner Assemblies P/N 204-010-433-001 & P/N 204-011-443-001: Installation Improvements.

**HELICOPTERS AFFECTED:** All Model 412 / 412EP helicopters.

**COMPLIANCE:** At Customer's Option

**DESCRIPTION:**

Bell Helicopter has received field reports of wear in subject Bearing and Liner Assemblies, specifically in the areas where the Bearing and Liner Assemblies attach into the Swashplate Gimbal Ring and Collective Sleeve. Wear may also be detected in the area of the Collective Lever pins. This wear is usually in form of fretting and can be detected by the presence of black oxide powder. The purpose of this bulletin is to correct these problems by applying sealant to the faying surfaces of the Bearings, Liners, Pins, and their attachment hardware.

**APPROVAL:**

The engineering design aspects of this bulletin are FAA/DER approved.

**MANPOWER:**

Approximately 8.0 man-hours are required to complete this bulletin. Man-hours are based on hands-on time, and may vary with personnel and facilities available.

**MATERIALS:**

**Required Material:**

The following material is required for the accomplishment of this bulletin and may be obtained through your Bell Helicopter Textron Supply Center.

<u>Part Number</u>	<u>Nomenclature</u>	<u>Quantity</u>
AN502-10-6	Screw	24

**Consumable Material:**

The following material is required to accomplish this bulletin, however this material is considered consumable (bench stock) material and may not require ordering depending on the operators consumable material stock levels. This material may be obtained through your Bell Helicopter Textron Supply Center.

<u>Part Number</u>	<u>Nomenclature</u>	<u>Quantity</u>	<u>Reference</u>
MIL-R-46082, TYPE I	Loctite RC/40	As Req'd	C-352
Denatured Alcohol	Denatured Alcohol	As Req'd	C-326
AS100028	Lockwire	As Req'd	C-405
P-C-451	Aluminum Oxide Cloth	As Req'd	C-406
L-P-0050	Abrasive Pad	As Req'd	C-407

**SPECIAL TOOLS:**

None required

**WEIGHT AND BALANCE:**

Not Affected

**ELECTRICAL LOAD DATA:**

Not affected

**REFERENCES:**

BHT-412-IPC Illustrated Parts Breakdown  
BHT-412-MM Maintenance Manual  
BHT-412-CR&O Component Repair and Overhaul Manual

**PUBLICATIONS AFFECTED:**

BHT-412-CR&O Component Repair and Overhaul  
BHT-412-MM Maintenance Manual

**ACCOMPLISHMENT INSTRUCTIONS:**

1. Disassemble Swashplate and Support Assembly and Hub and Sleeve Assembly sufficiently to remove Bearing and Liner Assemblies P/N 204-010-433-001 & P/N 204-011-443-001. Bearings should also be removed from Liners.
2. Inspect faying surfaces of Bearing Liners. Mechanical damage or corrosion is limited to 0.010 In. (0.25 mm) depth after repair, over an area no larger than 0.100 Sq. In. (65 Sq. mm). Maximum amount of repairs is 4 per Liner. Damage may be repaired using aluminum oxide cloth (C-406), ensuring only minimum material is removed to eliminate the damage. A fit of 0.000 In. to 0.001 In. (0.00 to 0.02 mm) between the Bearing outer race and the Liner ID must be maintained. The maximum acceptable axial or radial play of Bearing is 0.005 In. (0.13 mm). Binding or rough Bearings are not acceptable, and the Bearing OD should not be damaged.
3. Inspect faying surfaces of Collective Sleeve and Gimbal Ring. Collective Sleeve Bearing bore damage is limited to 0.001 In. (0.025 mm) for one quarter of circumference over one half the bore depth. Gimbal Ring Bearing bore damage is limited to 0.002 In. (0.0508 mm) for one quarter of circumference over one half the bore depth. Repair is limited to the use of abrasive pad (C-407).
4. Clean all faying surfaces with Denatured Alcohol (C-326) and wipe dry.
5. Apply Loctite RC/40 (C-352) sparingly to Bearing OD and ID of Liner, 6 places. Install Bearings into Liners while sealant remains wet.

**CAUTION**

Ensure that no sealant is allowed to enter the Bearings.

6. After verifying shim requirements of P/N 204-010-433-001, apply Loctite RC/40 (C-352) sparingly to faying surfaces of Bearing and Liner Assemblies, shims, Gimbal Ring, and (4) new Screws P/N AN502-10-6, 4 places. Install parts and torque Screws while sealant remains wet. Lockwire (C-405) Screws as required. Reference Figure 1.

**CAUTION**

Ensure that no sealant is allowed to enter the Bearings.

7. For P/N 204-011-443-001, apply Loctite RC/40 (C-352) sparingly to faying surfaces of Bearing and Liner Assemblies, Collective Sleeve, and (4) new Screws P/N AN502-10-6, 2 places. Install parts and torque Screws while sealant remains wet. Lockwire (C-405) Screws as required. Reference Figure 2.

**CAUTION**

Ensure that no sealant is allowed to enter the Bearings.

8. Reassemble remainder of Swashplate and Support Assembly and Hub and Sleeve Assembly.
9. Reference the BHT-412-MM, Chapter 62, for installation of the Collective Lever. Ensure sealant (C-352) is applied to all faying surfaces of Shims, Pins, Bearing ID, Lever bores, Washers, and Bolts. Reference Figure 2.
10. Annotate historical records to show compliance with this bulletin.

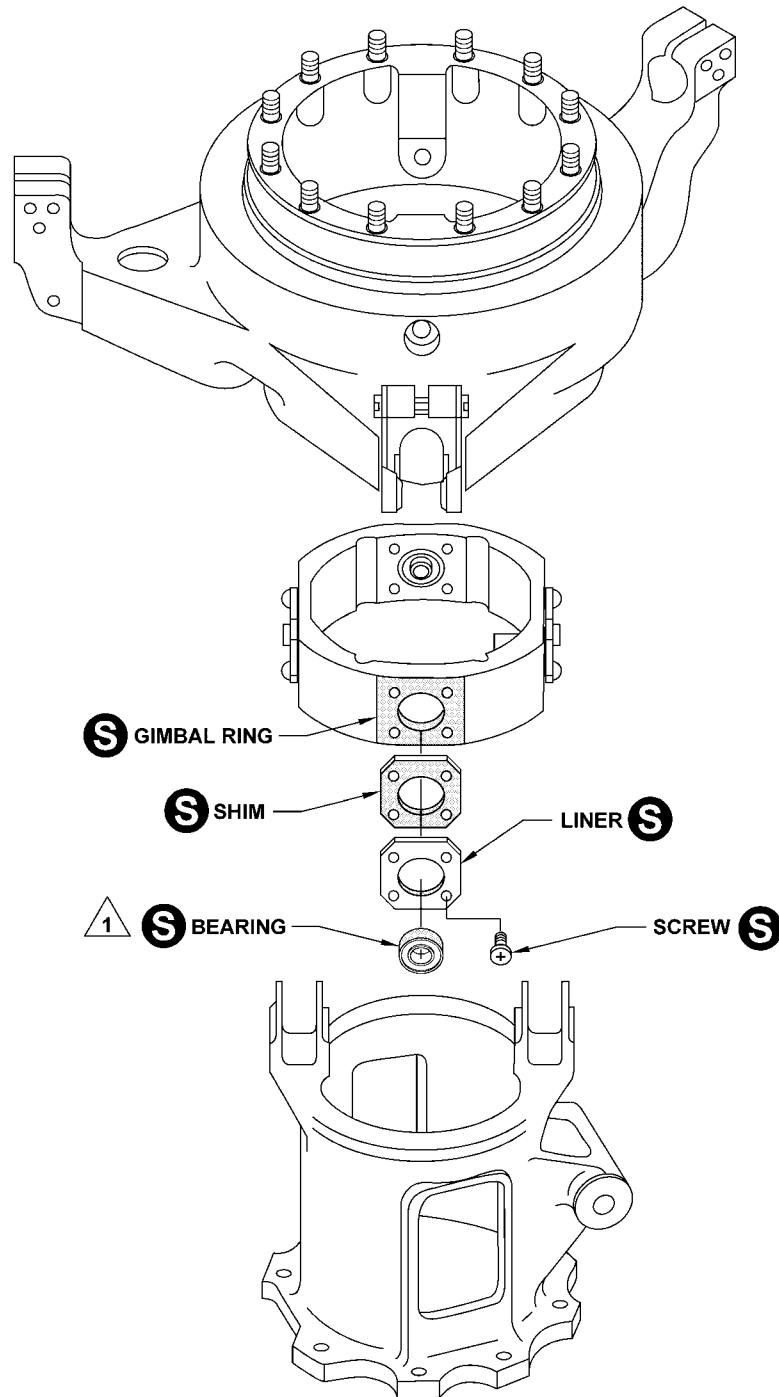

**NOTES**

**S** Apply sealant MIL-R-46082, TYPE I (C-352) to faying surfaces as indicated by shading.

**1** Ensure that no sealant is allowed to enter the bearing.

**Figure 1**

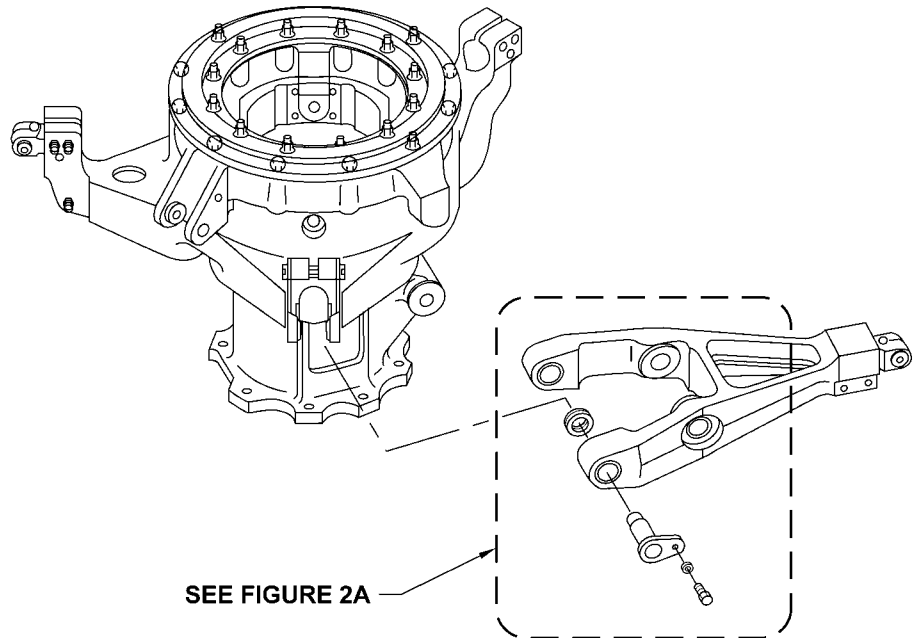
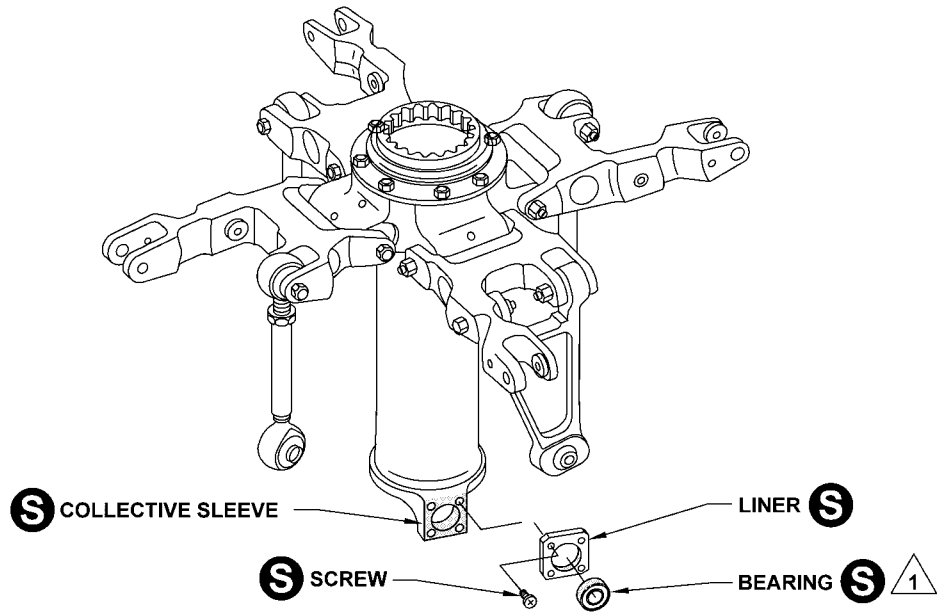

NOTES

**S** Apply sealant MIL-R-46082, TYPE I (C-352) to faying surfaces as indicated by shading.

**1** Ensure that no sealant is allowed to enter the bearing.

Figure 2

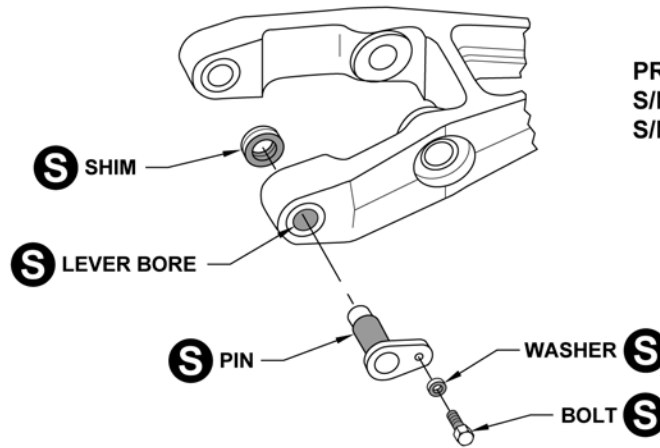

PRE TECHNICAL BULLETIN 412-88-68  
S/N 33001 THRU 33167  
S/N 34001 THRU 34024

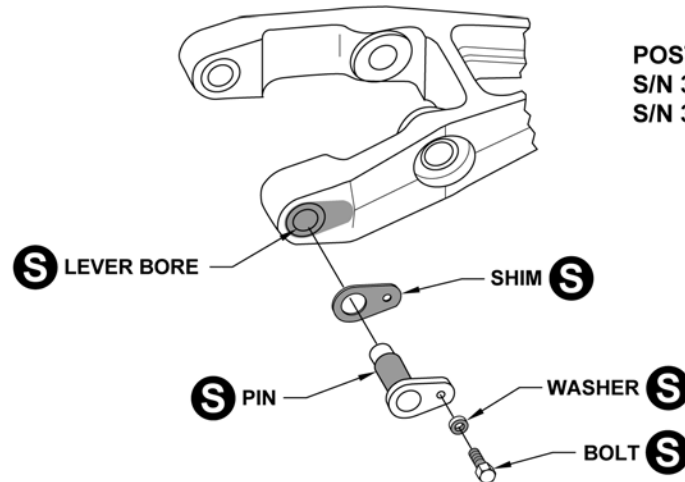

POST TECHNICAL BULLETIN 412-88-68  
S/N 33168 AND SUB.  
S/N 34025 AND SUB.

NOTES

**S** Apply sealant MIL-R-46082, TYPE I (C-352) to faying surfaces as indicated by shading.

**1** Ensure that no sealant is allowed to enter the bearing.

Figure 2A