

TECHNICAL BULLETIN
Bell Helicopter **TEXTRON**

A Subsidiary of Textron Inc.

No. 205-06-121

Date Jul 21, 2006

Page 1 of 4

DATE
REV

MODEL AFFECTED: 205A & 205A-1

SUBJECT: VERTICAL FIN COVER HINGE PIN IMPROVED
INSTALLATION

HELICOPTERS AFFECTED: Model 205A and 205A-1 helicopters serial
number 30001 through 30332.

COMPLIANCE: At Customer's Option

DESCRIPTION:

Bell Helicopter has designed a new installation for the vertical fin cover to prevent chaffing damage to the left hand spar cap caused by improperly bent hinge pins. This technical bulletin allows retrofit of the installation on 205A and 205A-1 aircraft.

APPROVAL:

The engineering design aspects of this bulletin are FAA/DER approved.

MANPOWER:

Approximately 0.5 man-hours are required to complete this bulletin. Man-hours are based on hands-on time, and may vary with personnel and facilities available.

WARRANTY:

There is no warranty provided for this bulletin.

MATERIALS:

Required Material:

The following material is required for the accomplishment of this bulletin and may be obtained through your Bell Helicopter Textron Supply Center.

<u>Part Number</u>	<u>Nomenclature</u>	<u>Quantity</u>
209-031-816-119	Pin Assy	2
209-031-816-123	Retainer	1
MS21042L3	Nut	2

SPECIAL TOOLS:

None required

WEIGHT AND BALANCE:

Not affected

ELECTRICAL LOAD DATA:

Not affected

REFERENCES:

BHT-205-IPB Illustrated Parts Breakdown
BHT-205-MM Maintenance Manual
BHT-ALL-SPM Standard Practices Manual
BHT-MED-SRM-1 Structural Repair Manual

PUBLICATIONS AFFECTED:

BHT-205-IPB Illustrated Parts Breakdown

ACCOMPLISHMENT INSTRUCTIONS:

1. Make helicopter ready for maintenance.
2. Open Vertical Fin Access Door P/N 209-031-816-005/105.

3. Remove Retainer P/N 209-031-816-035. Retain screws for reinstallation.
4. Remove door by removing hinge pins. Remove cotter pins at each end of the fixed half of hinge and discard.
5. Inspect spar cap as indicated in Figure 1, View A, for any chafing damage caused by improperly installed hinge pins.
 - a. Chafing damage of 0.040 inch-deep or less (up to the full width of the flange) may be blended to a length-to-depth ratio of 50:1 (in each direction from the deepest point) and refinished, provided the distance between the center of the nearest rivet and the repaired area is at least 1.5 time the rivet diameter (min E/D). Remove minimum amount of material and polish repair area using 400-grit sandpaper. Removal of the hinge from the fin may be required.
 - b. Perform a Fluorescent Penetrant Inspection per Standard Practices Manual, followed by application of chemical film to the repaired area per Structural Repair Manual Section 3-2-14. Refinish area in accordance with Standard Practices Manual.
 - c. Report any damage in excess of 0.040 inch-deep to Product Support Engineering.

-NOTE-

It is permissible to hand form pins on installation, to align attaching holes in pins and door without stress.

6. Reinstall door by inserting Pins P/N 209-031-816-119. Attach pins to door using existing screws, 209-031-816-123 Retainer and MS21042L3 Nuts, as shown on Figure 1. Close door.
7. Make an entry in helicopter historical records indicating compliance with this technical bulletin.
8. Make helicopter safe for flight.

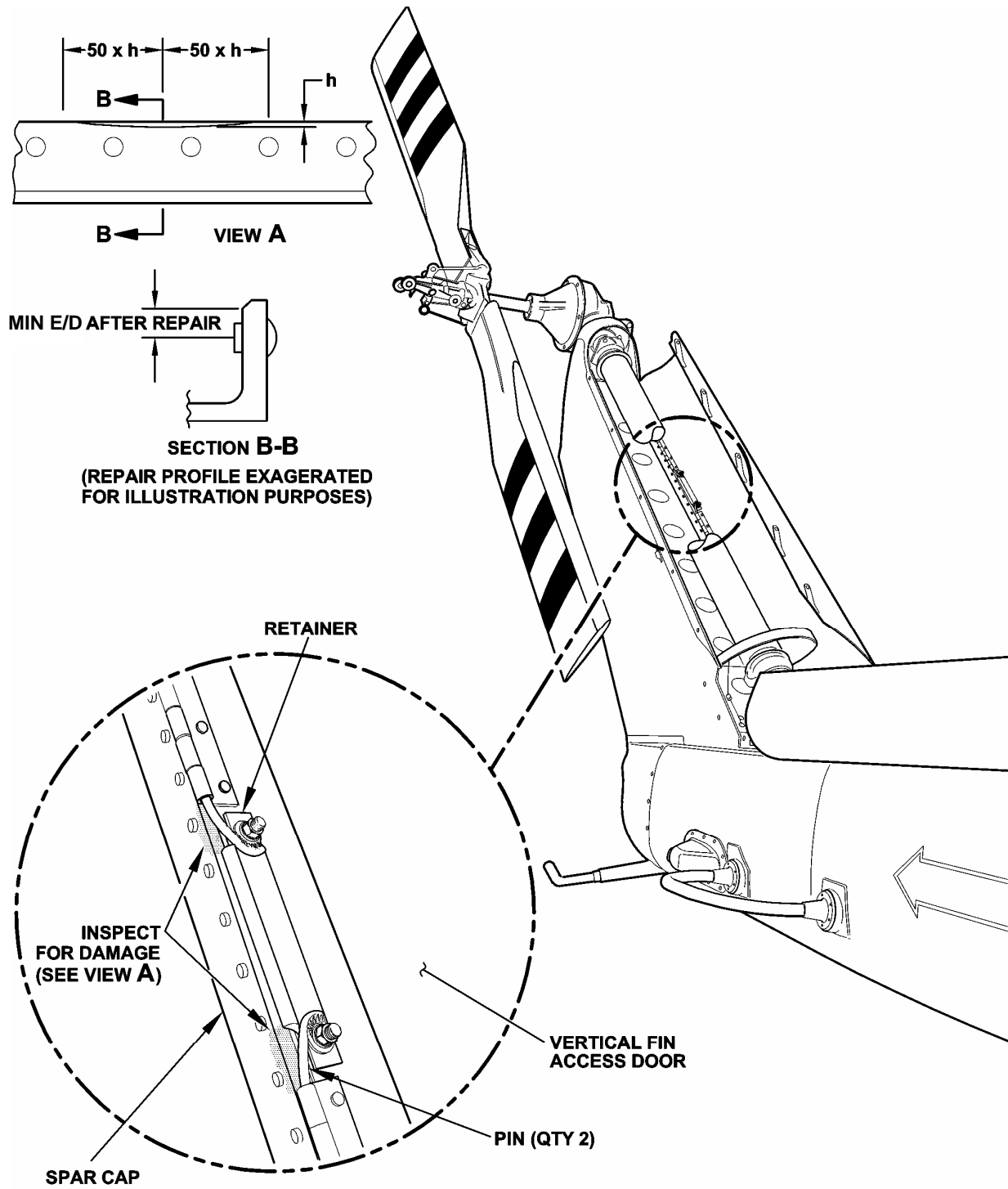

RAM 06505001

Figure 1
New Hinge Pin Installation