

Bell Helicopter **TEXTRON**

A Subsidiary of Textron, Inc.

December 7, 2005

TO: All Owners/Operators of Bell 206A/B Helicopters

**SUBJECT: REVISION "A" TO TECHNICAL BULLETIN 206-04-180:
(IMPROVED TAIL ROTOR GEARBOX INPUT SEAL P/N 206-340-
206-101, INTRODUCTION OF)**

Revision "A" to this Technical Bulletin introduces changes to seal installation procedure.

TECHNICAL BULLETIN
Bell Helicopter **TEXTRON**

A Subsidiary of Textron Inc.

No. 206-04-180

Date August 18, 2004

Page 1 of 7

DATE	Dec 07, 2005
------	--------------

REV	"A"
-----	-----

MODEL AFFECTED: 206A/B SERIES

SUBJECT: IMPROVED TAIL ROTOR GEARBOX INPUT SEAL P/N 206-340-206-101, INTRODUCTION OF

HELICOPTERS AFFECTED: 206A, S/N 004 through 660, and 672 through 715; 206B, S/N 661 through 671, and 716 through 4567 TH67, S/N 5101 through 5285.

206B, serial number 4568 and subsequent, and TH67, serial number 5286 and subsequent will have the intent of this bulletin accomplished prior to delivery.

COMPLIANCE: At Customer's Option

DESCRIPTION:

This bulletin is issued to introduce a new tail rotor gearbox input seal 206-340-206-101. The new seal is a double lip design, which has performed well in test and during field evaluation. It is anticipated that this seal will improve reliability and life over the seal currently used.

APPROVAL:

The engineering design aspects of this bulletin are Transport Canada approved.

MANPOWER:

Approximately 1.0 man-hours are required to complete this bulletin. Man-hours are based on hands-on time, and may vary with personnel and facilities available.

MATERIALS:

The material that follows is required to do this bulletin and can be obtained through your Bell Helicopter Supply Center.

<u>Part Number</u>	<u>Nomenclature</u>	<u>Quantity</u>
206-040-420-101	SPACER	1
206-340-206-101	SEAL	1
M83248/1-213	PACKING	1
M83248/1-230	PACKING	1
NAS1443-7P	LOCKWASHER	1

Consumable Material:

The following material is required to accomplish this bulletin, however this material is considered consumable (bench stock) material and may not require ordering depending on the operators consumable material stock levels. This material may be obtained through your Bell Helicopter Textron Supply Center.

<u>Part Number</u>	<u>Nomenclature</u>	<u>Reference</u>
ACETONE GALLON	SOLVENT	C-316
AMS-S-8802 6OZ	SEALANT	C-308
AS100028	LOCKWIRE	C-405
#1FLUID4OZ	ASSEMBLY FLUID	C-024

SPECIAL TOOLS:

PRESSING TOOL WORK AID (Figure 2)

WEIGHT AND BALANCE:

Not affected

ELECTRICAL LOAD DATA:

Not affected

REFERENCES:

BHT-206A/B-Series-Maintenance Manual, Original Issue January 07,1998
Chapter 65

BHT-206A/B-Maintenance and Overhaul Manual, Revision 41, November 21, 1995.
Section VI.

BHT-206B3-CR&O, Revision 1, August 22, 1993
Chapter 65.

BHT-206A/B-IPB, Revision 2, August 01, 1998
Chapter 65.

PUBLICATIONS AFFECTED:

BHT-206A/B-IPB, Revision 2, August 01, 1998
Chapter 65.

ACCOMPLISHMENT INSTRUCTIONS:

-NOTE-

You can replace the input seal with the tail rotor gearbox installed on the aircraft.

1. Remove the applicable cowlings to get access to the tail rotor driveshaft and the tail rotor gearbox (BHT-206A/B-M&O, Section VIII)(BHT-206BA/B-SERIES-MM, Chapter 53).
2. Remove the tail rotor driveshaft assembly attached to the tail rotor gearbox (BHT-206A/B-M&O, Section VI)(BHT-206B3-MM, Chapter 65)
3. Remove the tail rotor gearbox input seal (1, Figure 1) and spacer (2) (BHT-206A/B-M&O, Section VI)(BHT-206B3-CR&O, Chapter 65). Discard input seal (1).

-NOTE-

Keep the shipping cup installed on the seal until installation of the input pinion outer nut

A

4. Install the new seal (1) as follows:

- a. Clean the input outer nut (2, Figure 2) with solvent (C-316).
- b. Remove the shipping cup from the seal (1) before pressing it in the input pinion outer nut (2).

-NOTE-

Do not use a hydraulic press to install the seal (1). Use an arbor press. Excessive pressure can deform the seal case, distort the sealing lip, and cause leakage to occur.

-NOTE-

Do not apply sealant to the outer diameter of the seal (1) or the inside diameter of the input outer nut (2).

- c. Use the work aid (Detail A) and press the seal (1) into the input outer nut (2) with the felt wiper (3) facing outboard. Push the seal (1) in the nut (2) evenly and smoothly until seated.
- d. Install the protective shipping cup into the seal (1).
- e. Apply a small bead of sealant (C-308) as shown in Figure 2.

-NOTE-

At this point, to prevent inverting the input seal lip, do not install the spacer (2).

5. Lubricate packing (3, Figure 1) with assembly fluid (C-024) and install.

6. Remove the protective shipping cup from the input seal (1) .

A 7. Apply system lubricant to the seal lips and spacer (2).

8. Lubricate the new packing (4) with assembly fluid (C-024) and install on the input pinion outer nut (5).

9. Install input pinion outer nut (5) first and spacer (2) second (BHT-206A/B-M&O, Section VI)(BHT-206B3-CR&O, Chapter 65).

10. Install input pinion inner nut (6), and a new lockwasher (7) on the tail rotor gearbox assembly (BHT-206A/B-M&O, Section VI)(BHT-206B3-CR&O, Chapter 65).

11. Re-identify the tail rotor gearbox assembly.

Example: 206-040-400-XXXFM1
or
206-040-402-XXXFM1

12. Install the tail rotor driveshaft assembly to the tail rotor gearbox (BHT-206A/B-M&O, Section VI)(BHT-206B3-MM, Chapter 65).

13. Do a ground run of the helicopter and do a check for oil leaks (Refer to applicable Helicopter Flight Manual).

14. Install the tail rotor gearbox cowlings and the tail rotor driveshaft cover (BHT-206A/B-M&O, Section VIII)(BHT-206BA/B-SERIES-MM, Chapter 53).

15. Make an entry in the helicopter Historical Record to show that this Technical Bulletin is completed.

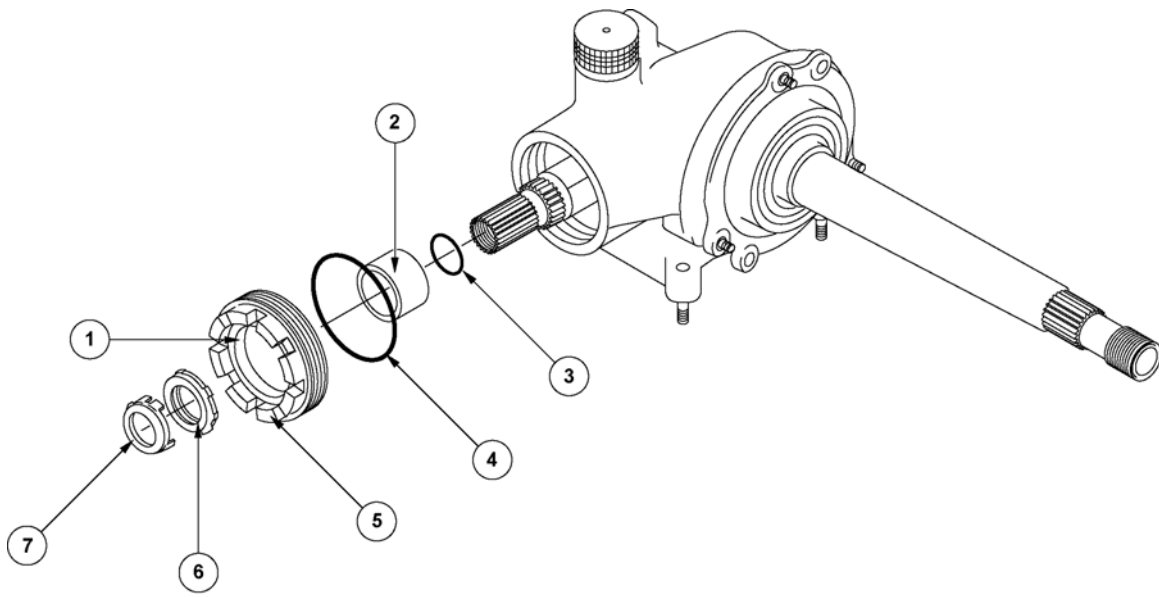

LEGEND

- 1. Input seal (206-340-206-101)
- 2. Spacer (206-040-420-101)
- 3. Packing (M83248/1-213)
- 4. Packing (M83248/1-230)
- 5. Input pinion outer nut
- 6. Input pinion inner nut
- 7. Lockwasher (NAS1443-7P)

03531001_IM

Figure 1. Tail Rotor gearbox input pinion outer nut - Installation

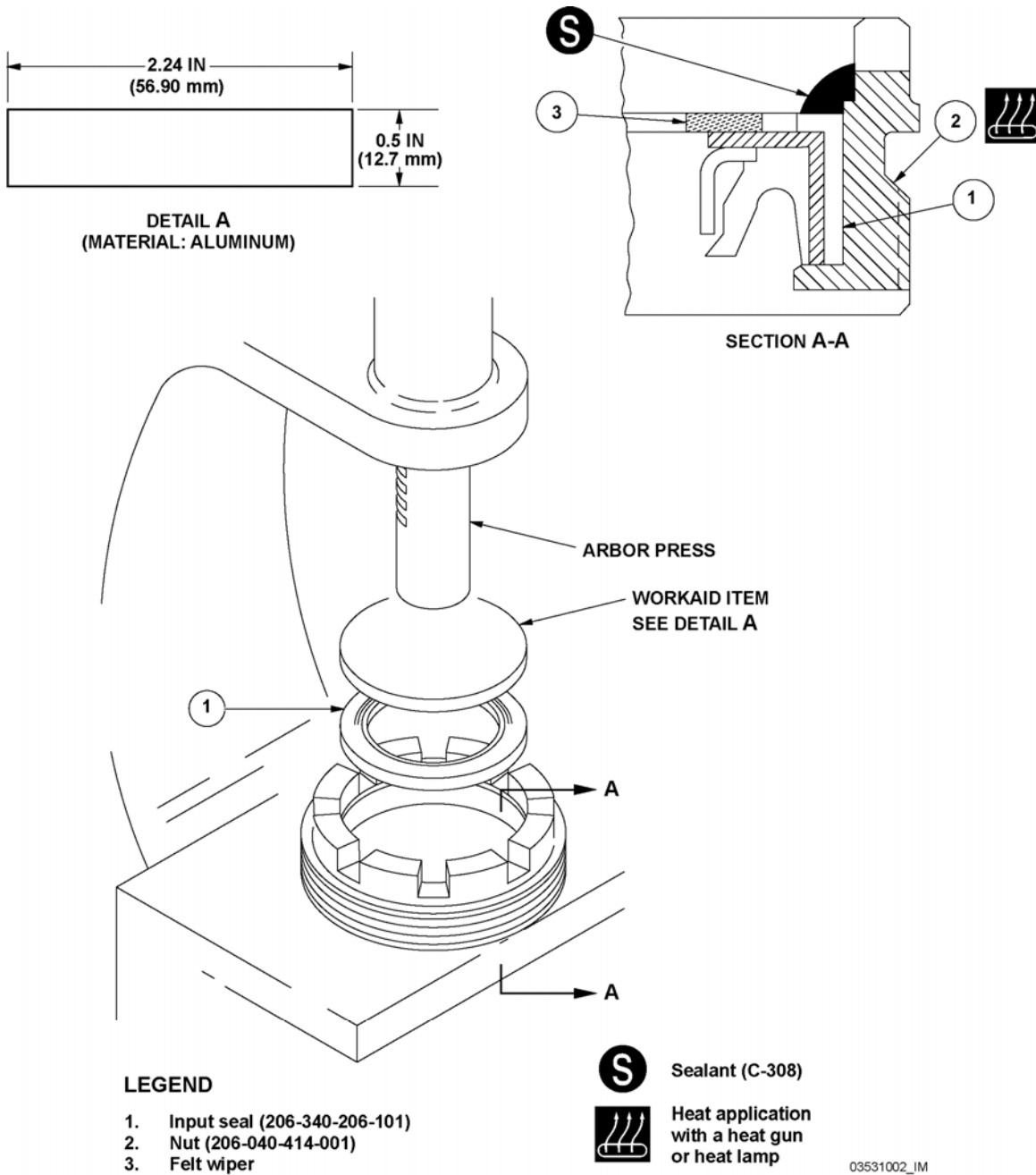

Figure 2. Seal 206-340-206-101 - Installation