

TECHNICAL BULLETIN
Bell Helicopter **TEXTRON**

A Subsidiary of Textron Inc.

No. 206-06-187

Date Sept. 25, 2006

Page 1 of 5

DATE
REV

MODEL AFFECTED **206A/B SERIES**

SUBJECT: **BAGGAGE FLOOR PANEL, IMPROVED
CORROSION RESISTANCE OF,**

HELICOPTERS AFFECTED: **206A helicopters: s/n 004 through 660, and 672
through 725.**
**206B helicopters: s/n 661 through 671, 716
through 4523, 4524 through 4586, 5101
through 5267 and 5268 through 5305.**

**(Helicopters s/n 4587 and subsequent plus
Serial Number 5306 and subsequent will have
the intent of this bulletin accomplished prior to
delivery.**

COMPLIANCE: **At Customer's Option**

DESCRIPTION:

This bulletin introduces the addition of washers and sealant to provide improved corrosion protection to the baggage floor panel at the footman loop locations.

APPROVAL:

The engineering design aspects of this bulletin are TCCA approved.

MANPOWER:

Approximately 2.0 hours are required to complete this bulletin. Hours are based on hands-on time, and may vary with personnel and facilities available.

WARRANTY:

Not affected

MATERIALS:

Required Material:

The following material is required for the accomplishment of this bulletin and may be obtained through your Bell Helicopter Textron Supply Center.

<u>Part Number</u>	<u>Nomenclature</u>	<u>Quantity</u>
140-009A13T48	Washer	8
NAS1149D0316J	Washer	4

Consumable Material:

The following material is required to accomplish this bulletin, however this material is considered consumable (bench stock) material and may not require ordering depending on the facility consumable material stock levels. This material may be obtained through your Bell Helicopter Textron Supply Center.

<u>Part Number</u>	<u>Nomenclature</u>	<u>Quantity</u>	<u>Reference</u>
MIL-PRF-81733	Sealant (proseal)	As Required	C-251
MIL-PRF-23377, Type I, Class C	Primer	As Required	C-204
MIL-PRF-16173, Grade 2	Corrosion Preventative Compound	As Required	C-104

SPECIAL TOOLS:

None required

WEIGHT AND BALANCE:

Not affected

ELECTRICAL LOAD DATA:

Not affected

REFERENCES:

BHT-ALL-SPM Standard Practices Manual, Chapter 3. Revision 1.

PUBLICATIONS AFFECTED:

BHT-206A/B-IPB Illustrated Parts Breakdown, Chapter 53, Figure 25.

ACCOMPLISHMENT INSTRUCTIONS:

1. Gain access to the baggage floor panel.
2. Remove all six footman loops (1, Figure 1, sheet 2) from floor panel.
3. Inspect footman loops (1), inserts (3) and screws (5) for evidence of corrosion. Replace unserviceable screws (5) and footman loops (1). Replace damaged or corroded inserts (refer to BHT-206-SRM-1). Remove corrosion on inserts as per Standard Practices Manual, Chapter 3.
4. Inspect baggage floor panel for damage or corrosion around insert location. If required, repair baggage floor panel in accordance with BHT-206-SRM Chapter 3.
5. Prime any bare metal surfaces with epoxy primer (C-204).
6. Prior to installing the footman loops (1) apply corrosion inhibiting compound (C-104) on screw shank
7. Apply sealant (C-251) per figure 1 DETAIL C, D and E. Reinstall the footman loops (1). Contour sealant as shown in DETAIL C, D and E.

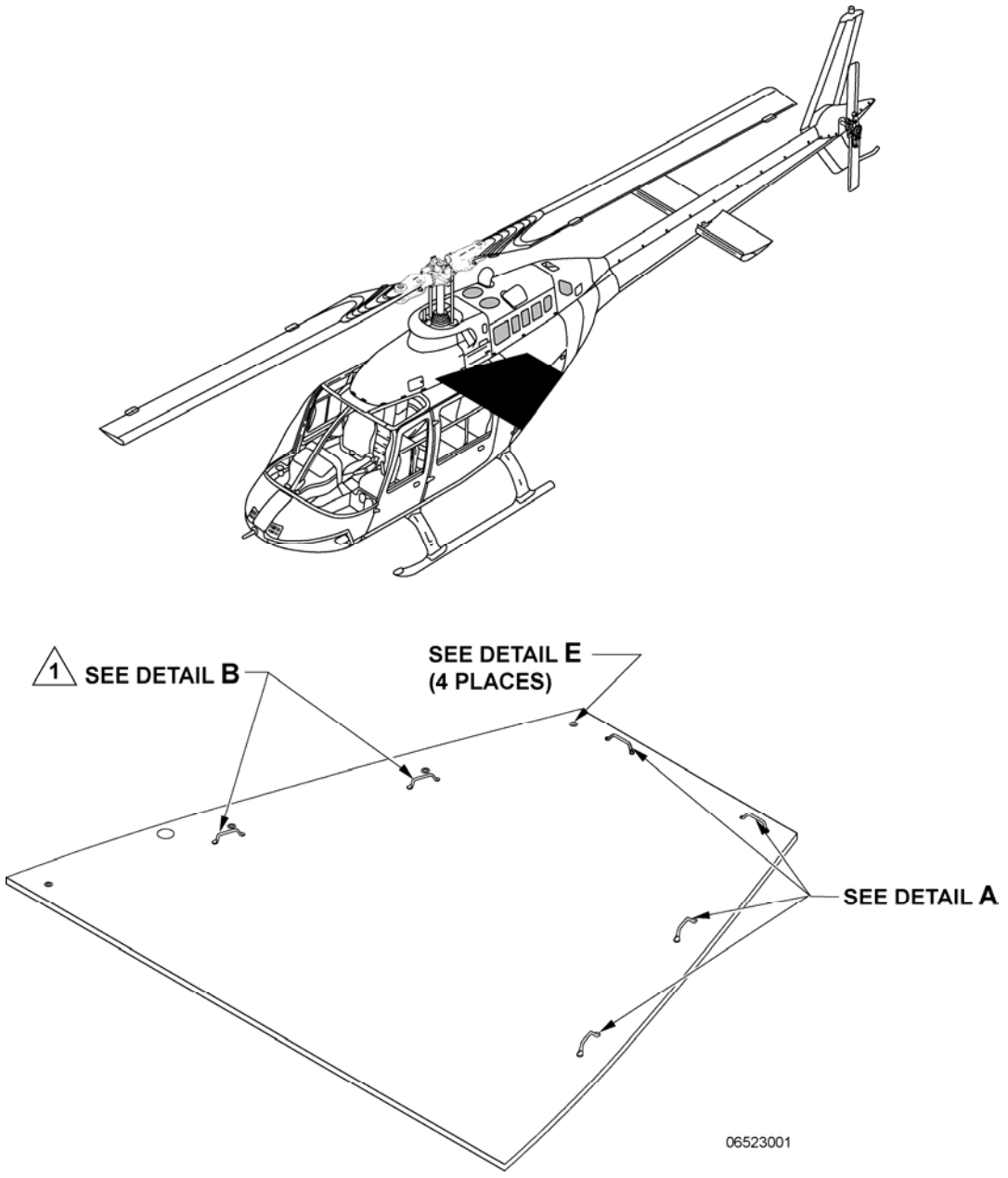

**Figure 1: Baggage Floor Panel (sheet 1 of 2)
206A/B Helicopters**

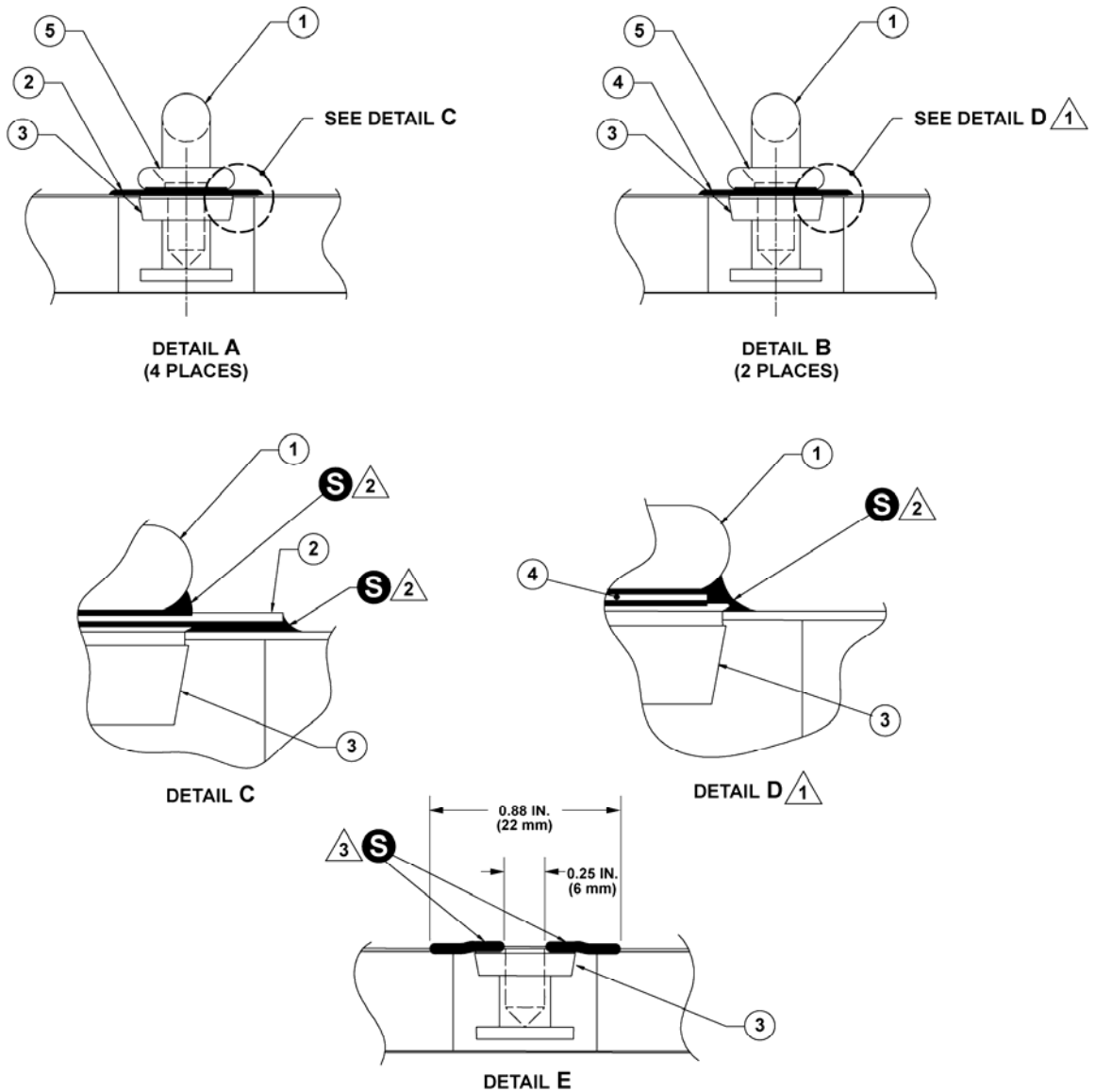

- 1. Footman loop (90-009 Ref)
- 2. Washer (140-009A13T48)
- 3. Insert (Ref)
- 4. Washer (NAS1149D0316J)
- 5. Screw (MS24694-S47 Ref)

S SEALANT (C-251)

NOTE

- △1 Detail B uses reduced diameter washers NAS1149D0316J.
- △2 Seal faying surfaces.
- △3 Overcoat top of insert and surrounding area.

06522, 23, 24_002

**Figure 1: Baggage Floor Panel (sheet 2)
206A/B Helicopters**