

TECHNICAL BULLETIN  
**Bell Helicopter**  
A Textron Company

No. 212-08-207

Date Feb 26, 2008

Page 1 of 9

DATE
REV

**MODEL AFFECTED:** 212

**SUBJECT:** UPPER CREW DOOR HINGE STRUCTURE,  
REINFORCEMENT OF.

**HELICOPTERS AFFECTED:** Model 212 helicopters serial number 30502 through 31311, 32101 through 32142 and 35001 through 35103.

[Model 212 helicopters serial number 35104 and subsequent will have the intent of this bulletin accomplished prior to delivery]

**COMPLIANCE:** At Customer's Option

**DESCRIPTION:**

Bell Helicopter has received some reports of cracking occurring at supports P/N 204-030-662-037 & -038 (or the earlier -025 & -026) caused by the crew doors repeatedly hitting their open stop, especially under windy conditions. This bulletin provides the instructions for a simple reinforcement to the surrounding area.

**APPROVAL:**

The engineering design aspects of this bulletin are FAA/DER approved.

**MANPOWER:**

Approximately 24 man-hours are required to complete this bulletin. Man-hours are based on hands-on time, and may vary with personnel and facilities available.

**MATERIALS:**

**Required Material:**

The following material is required for the accomplishment of this bulletin and may be obtained through your Bell Helicopter Textron Supply Center.

<u>Part Number</u>	<u>Nomenclature</u>	<u>Quantity</u>
204-030-662-121	Support	1
204-030-662-122	Support	1
204-030-662-119	Doubler	1
204-030-662-120	Doubler	1
204-030-662-129	Shim	2
204-030-664-121	Support	1 (see note)
204-030-664-122	Support	1 (see note)
204-030-725-121	Ejection Assy	2 (see note)
120-098-05D12	Shim	2
20-042-8-14	Radius Block	2
MS27039-1-13	Screw	4
MS20470AD4-4	Rivet	20

Note: If desired only. Existing part may be reworked. See text.

**Consumable Material:**

The following material is required to accomplish this bulletin, however this material is considered consumable (bench stock) material and may not require ordering depending on the operators consumable material stock levels. This material may be obtained through your Bell Helicopter Textron Supply Center.

<u>Part Number</u>	<u>Nomenclature</u>	<u>Quantity</u>	<u>Reference</u>
299-947-100TY2CL28OZ	Adhesive	1	C-317
AMS-S-8802 PT	Sealant	1	C-308

**SPECIAL TOOLS:**

None required

**WEIGHT AND BALANCE:**

Not affected

**ELECTRICAL LOAD DATA:**

Not affected

**REFERENCES:**

BHT-212-IPB Illustrated Parts Breakdown  
BHT-212-MM Maintenance Manual

**PUBLICATIONS AFFECTED:**

BHT-212-IPB Illustrated Parts Breakdown

**ACCOMPLISHMENT INSTRUCTIONS:**

1. Prepare aircraft for maintenance.
2. Remove crew doors.
3. Remove upper door hinges P/N 204-031-837-011 and -012 from aircraft structure. Retain hardware for reinstallation.
4. Remove door-jettisoning mechanisms. Retain hardware for reinstallation.

**-NOTE-**

Refer to Figure 1 for the following steps. When removing rivets, note type, size and location for reassembly.

5. On left side, remove instrument panel support fitting (9).
6. Remove strap (10).
7. Remove support (1) and support (8) as a unit. Remove support (8) from support (1).
8. Fit new support (1). See note 1 in Figure 1. Measure gap between forward leg of support (1) and frame (7), View B and Section C-C. If gap is less than 0.063 inch, peel or grind shim (2), taper or straight, as required to fill gap without stress on support (1) and discard shim (3). If gap is 0.063 inch or more, install shim (3) in addition to shim (2), peeled or ground as required. Secure with Cleco fasteners.

9. Fit doubler (4) and radius block (5); refer to View A. See note 1 in Figure 1. Verify for possible interference with support (8) and trim doubler as required. Trim radius block to follow edge of doubler (4) and support (1). Secure with Cleco fasteners.
10. Rework existing support (8) or replace with new support, as per Figure 2.
11. Fit existing fitting (9) and reworked (or new) support (8). Secure with Cleco fasteners.
12. Remove supports (1 and 8), shims (2 and 3), doubler (4), radius block (5), fitting (9) and deburr.
13. Apply adhesive (C-317) to doubler (4) and radius block (5) and install using MS20470AD4 rivets.
14. Install support (8) on support (1)
15. Install supports (1 and 8) and shims (2 and 3) as required.
16. Install fitting (9) and strap (10).
17. Re-install upper door hinge using existing hardware except replace two existing screws with two MS27039-1-13 screws at the aft holes.
18. Rework existing ejection assy as per Figure 2 or replace with new ejection assy. Re-install door-jettisoning mechanism.
19. Repeat steps 5 to 18 for right side.
20. Apply a bead of sealant (C-308) around upper door hinges, doublers (4), radius blocks (5) and refinish as required.
21. Re-install crew doors.
22. Prepare aircraft for flight.
23. Make an entry in helicopter historical records indicating compliance with this technical bulletin.

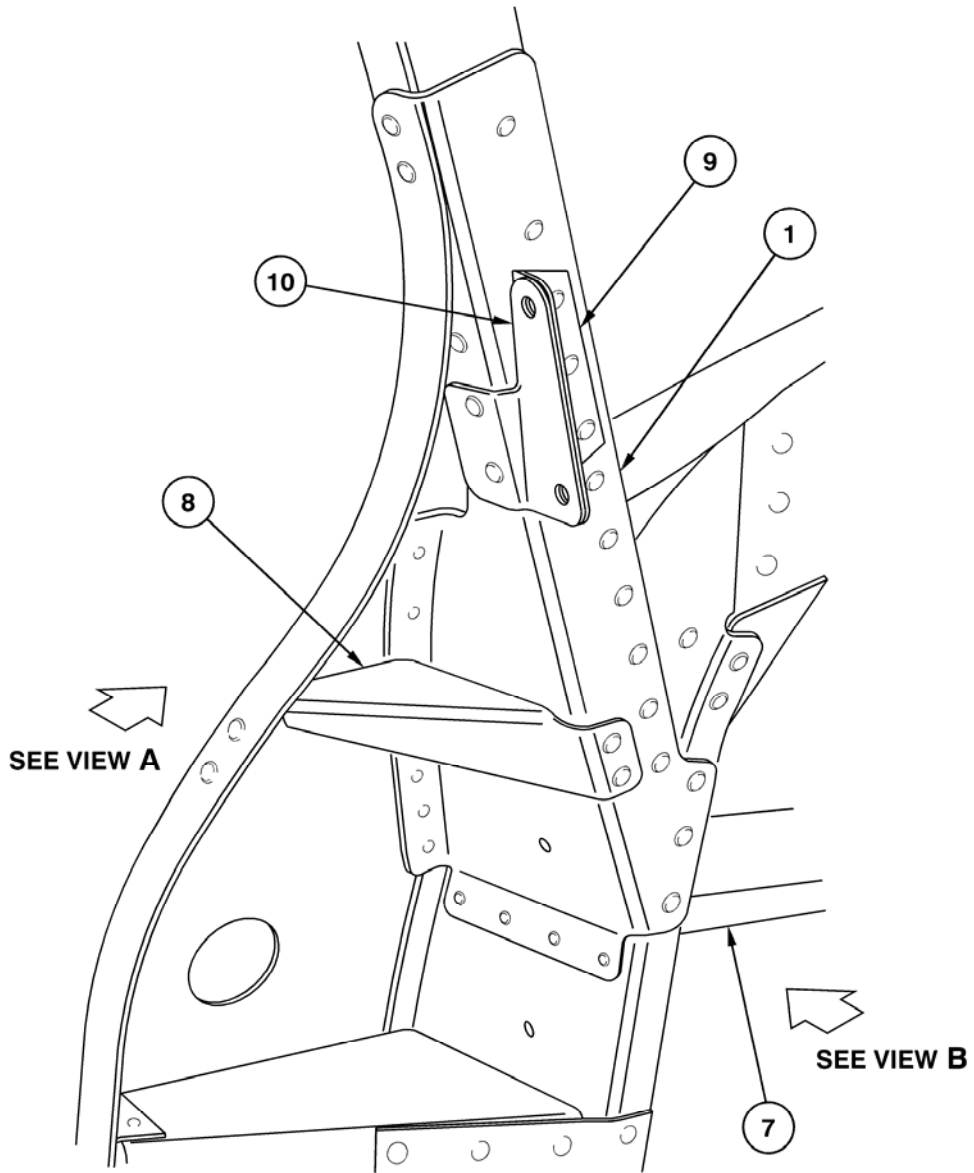

Figure 1 (Sheet 1 of 4)

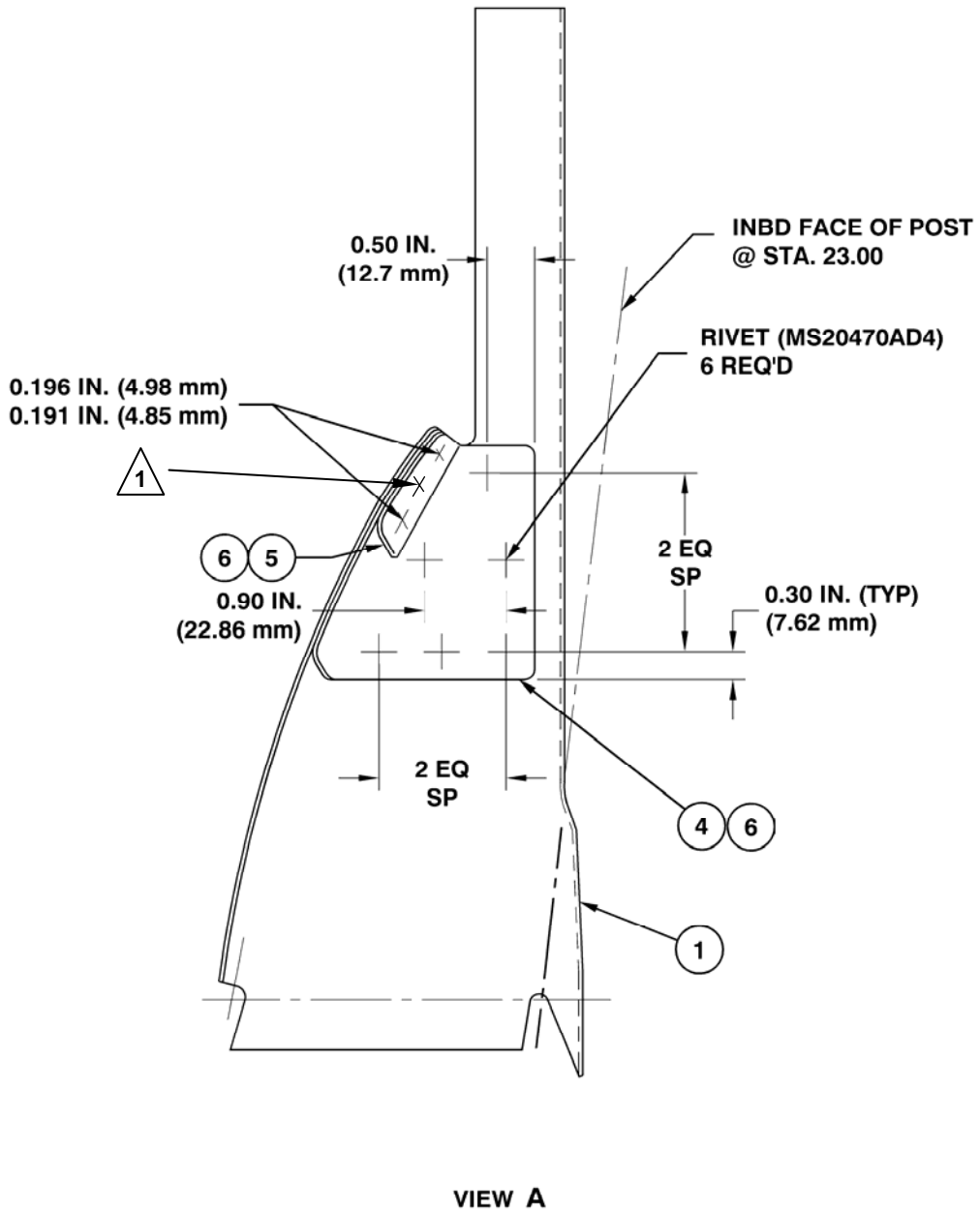
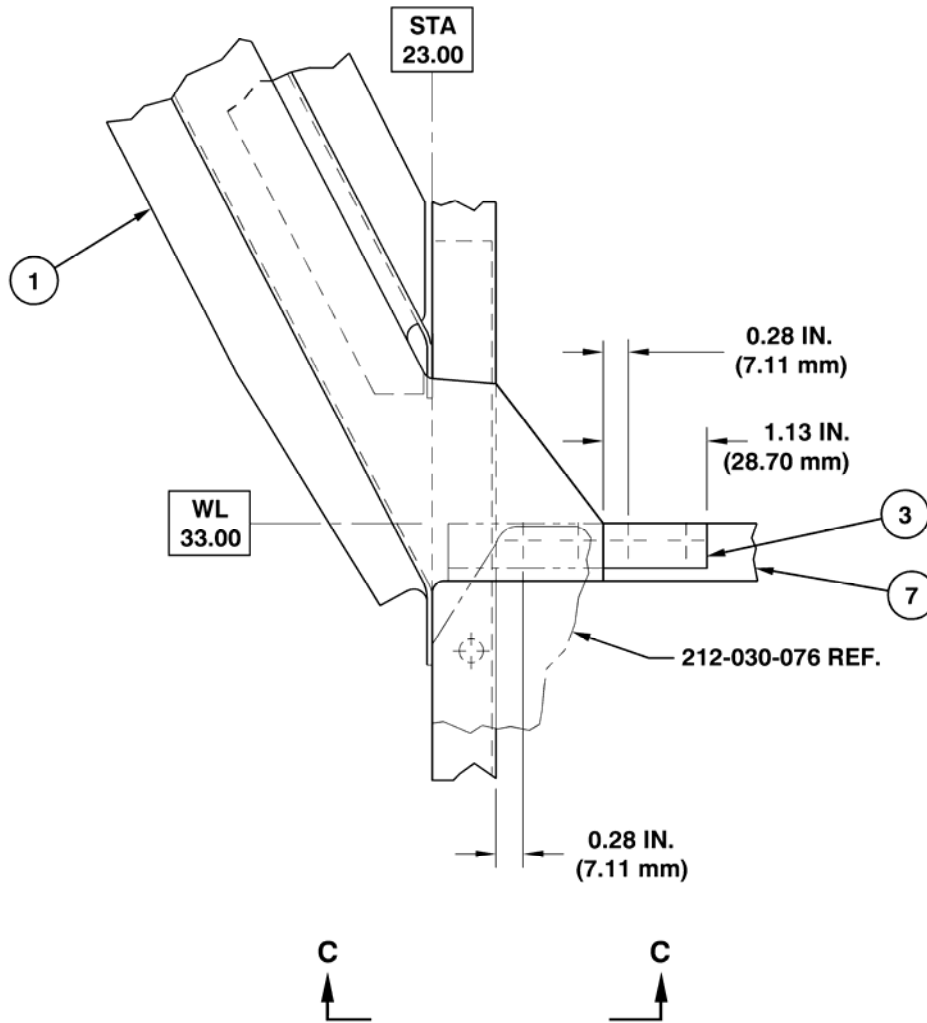
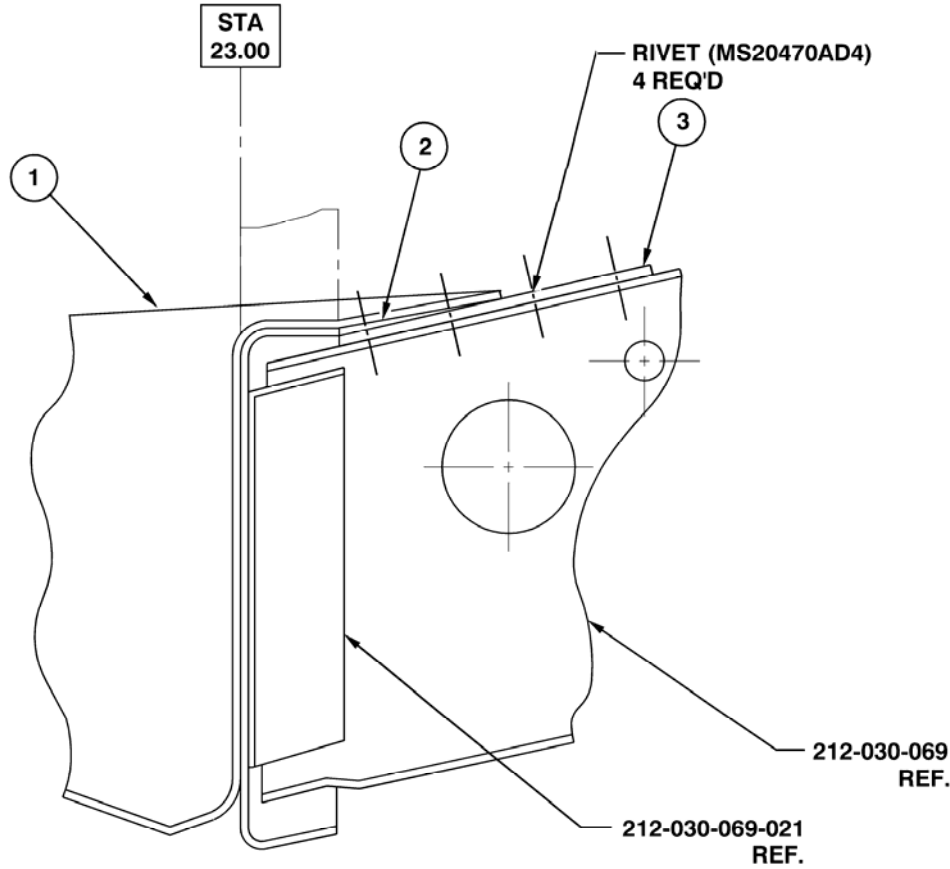

Figure 1 (Sheet 2 of 4)



**VIEW B**  
**VIEW LOOKING OUTBOARD**

**Figure 1 (Sheet 3 of 4)**



**SECTION C-C  
VIEW LOOKING UP**

1. Existing support LH (204-030-662-037)  
Existing support RH (204-030-662-038)  
New support LH (204-030-662-121)  
New support RH (204-030-662-122)
  2. Shim (120-098-05D12)
  3. Shim (204-030-662-129)
  4. Doubler LH (204-030-662-119)  
Doubler RH (204-030-662-120)
  5. Radius block (20-042-8-14)
  6. Adhesive (299-947-100 Type II, CL2)
  7. Existing frame (ref.)
  8. Existing support (ref.)
  9. Existing fitting (ref.)
  10. Existing strap (ref.), if applicable
-  Existing rivet hole, countersink this hole in doubler (4), dimple in support (1)

02592004

**Figure 1 (Sheet 4 of 4)**

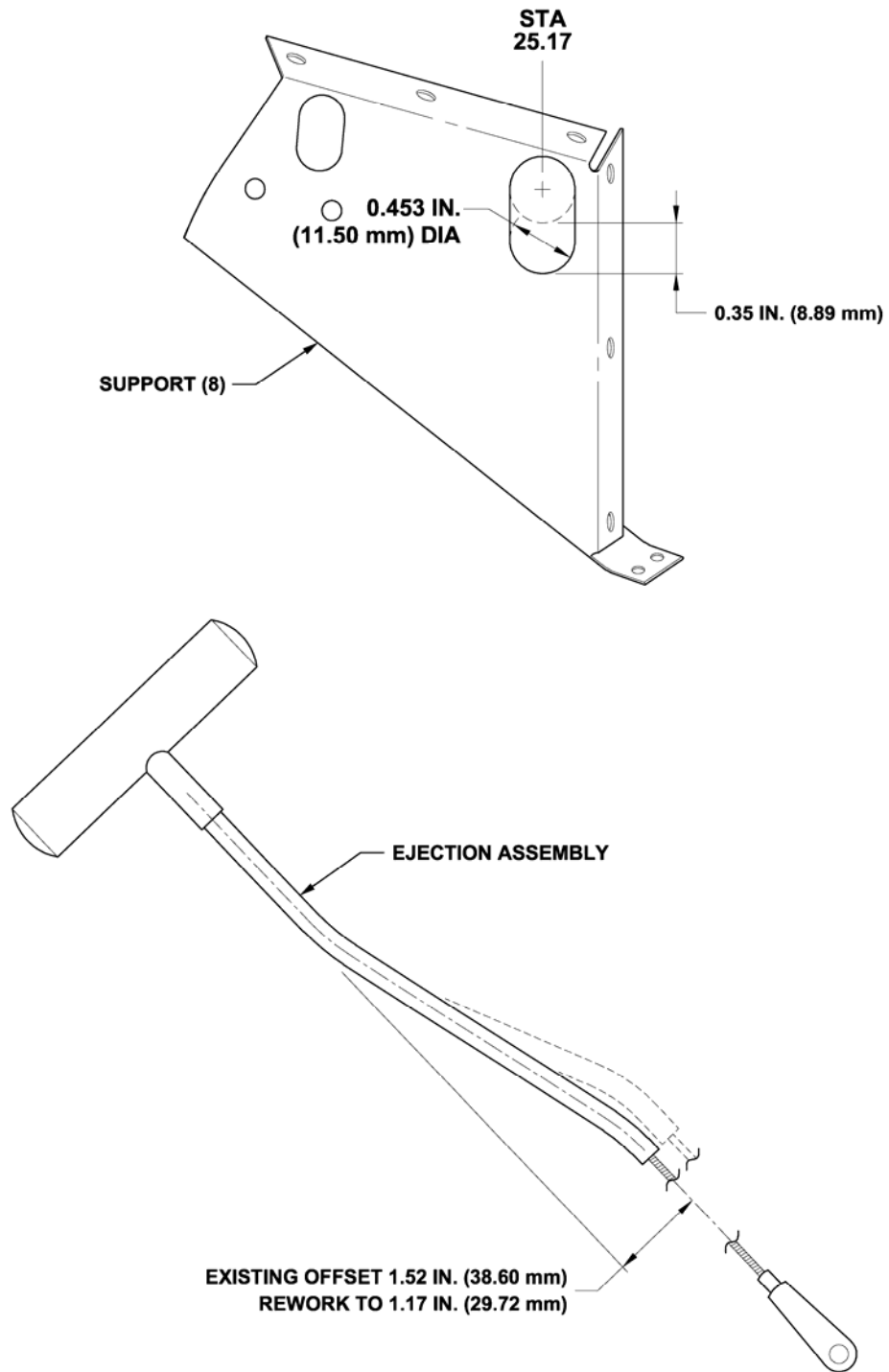

Figure 2