

TECHNICAL BULLETIN

Bell Helicopter

A Textron Company

No. 214-09-96
Date 10-21-09
Page 1 of 10

DATE
REV

MODEL AFFECTED: 214B/214B-1

SUBJECT: ALTERNATE MAIN ROTOR DRAG BRACE ASSEMBLY, P/N 214-010-191-101, INTRODUCTION OF

HELICOPTERS AFFECTED: All Model 214B/214B-1 helicopters

COMPLIANCE: At Customer's Option

DESCRIPTION:

An alternate for P/N 214-010-113-107 Main Rotor Drag Brace Assembly has been approved for use in the 214B Series helicopters. P/N 214-010-191-101 Drag Brace Assembly may be installed in lieu of the P/N 214-010-113-107 Drag Brace Assembly as described in the accomplishment instructions of this technical bulletin.

In addition, maintenance and overhaul procedures, weight and balance, and airworthiness life are affected by installation of the P/N 214-010-191-101 Drag Brace Assemblies. The specific differences applicable to the P/N 214-010-191-101 Drag Brace Assemblies are provided in the accomplishment instructions and are to be used pending formal incorporation into the appropriate 214B manuals.

APPROVAL:

The engineering design aspects of this bulletin are FAA approved.

MANPOWER:

Approximately 2.0 man-hours are required to complete this bulletin when performed in conjunction with other scheduled main rotor hub assembly maintenance. Man-hours are based on hands-on time, and may vary with personnel and facilities available.

WARRANTY:

There is no warranty credit applicable for parts or labor associated with this Bulletin.

MATERIALS:

Required Material:

The following material is required for the accomplishment of this bulletin and may be obtained through your Bell Helicopter Textron Supply Center.

-NOTE-

BHT does not stock the P/N 214-010-191-101 Drag Brace as an assembly, order details only as shown below. Quantities listed are for two (2) drag brace assemblies. Refer to the Accomplishment Instructions of this Technical Bulletin for assembly information.

<u>Part Number</u>	<u>Nomenclature</u>	<u>Quantity</u>
214-010-192-101	Barrel Assembly	2
214-010-193-101	Clevis Assembly	2
214-010-194-101	Nut	4
214-210-001-101	Wrench, Crowfoot	1
140-007-113-78A5	Washer	2

Consumable Material:

The following material is required to accomplish this bulletin, however this material is considered consumable (bench stock) material and may not require ordering depending on the operators consumable material stock levels. This material may be obtained through your Bell Helicopter Textron Supply Center.

<u>Part Number</u>	<u>Nomenclature</u>	<u>Quantity</u>	<u>Reference</u>
AS100028	Lockwire	A/R	C-405
MIL-C16173 GR1 PT	CPC	A/R	C-101
MIL-C-16173, GR2 6OZ	CPC	A/R	C-104
N/A	Slippage Mark Paint	A/R	N/A

SPECIAL TOOLS:

P/N 214-210-001-101 Wrench, Crowfoot

WEIGHT AND BALANCE:

<u>Weight</u>	<u>Longitudinal</u>		<u>Lateral*</u>	
	<u>Arm</u>	<u>Moment</u>	<u>Arm</u>	<u>Moment</u>
+15.3 Lbs (+6.94 kg)	134 in. (3404 mm)	+2050 in-Lbs (+23.62 kg x mm/100)	0.0 in. (0 mm)	0.0 in-Lbs (0 kg x mm/100)

* In lateral calculations, - is left and + is right.

ELECTRICAL LOAD DATA:

Not affected

REFERENCES:

BHT-214B-IPB, Chapter 62

BHT-214B-MM-1, Chapters 4, 5, 8, and 65

BHT-214B-CR&O, Chapter 65

BHT-ALL-SPM

ASB 214-86-33, "Drag Brace Assembly, P/N 214-010-113-001/-003, Replacement Of" dated 6/2/86.

PUBLICATIONS AFFECTED:

BHT-214B-IPB, Rev 3, Chapter 62

BHT-214B-MM, Rev 5, Chapters 4, 5, and 65

BHT-214B-CR&O, Rev 3, Chapter 65

ACCOMPLISHMENT INSTRUCTIONS:

1. P/N 214-010-191-101 Drag Brace Assembly may be used as an alternate for P/N 214-010-113-107 Drag Brace Assembly but must be installed in pairs. Installation of one P/N 214-010-113-107 Drag Brace Assembly and one P/N 214-010-191-101 Drag Brace Assembly on the same main rotor hub assembly is **not approved**.

2. The following components of the P/N 214-010-191-101 Drag Brace Assembly (see Figure 1) are subject to an airworthiness limitation (retirement life) as noted below:

- a. P/N 214-010-192-101 Barrel Assembly 10,000 hours
- b. P/N 214-010-193-101 Clevis Assembly 10,000 hours

3. Refer to the 214B Maintenance Manual and Component Repair and Overhaul Manual for removal, disassembly, inspection, repair, reassembly, and reinstallation except as noted in the following paragraphs.

a. 214B Maintenance Manual, BHT-214B-MM-1:

1) *Chapter 5, Special Inspection – Add the following paragraph*

**5-7A. BETWEEN 10 TO 25 FLIGHT HOURS FOLLOWING
INSTALLATION OR ADJUSTMENT**

P/N 214-010-191-101 DRAG BRACE ASSEMBLY

Torque check drag brace assembly nut (Chapter 65).

2) *Chapter 65, Rotor Systems – Add the following paragraph*

65.12A. P/N 214-010-191-101 DRAG BRACE INSPECTION

NOTE

**REQUIRED BY SPECIAL INSPECTION (BETWEEN 10
TO 25 FLIGHT HOURS FOLLOWING INSTALLATION
OR ADJUSTMENT) CHAPTER 5.**

1. Remove corrosion preventative compound and lockwire from both nuts.

2. Confirm inboard drag brace nut torque by holding the outboard nut and, using P/N 214-210-001-101 Wrench, applying torque to the inboard nut in the increasing torque direction (do not loosen nut), and verify 575 to 600 foot-pounds torque.

a. If torque is correct:

1) Reapply slippage mark paint and lockwire (C-405) nuts together.

2) Reapply corrosion preventative compound (C-101) to nuts and exposed threads on barrel; allow compound to dry to the touch before flight.

b. If torque is less than 575 foot-pounds:

1) Ensure corrosion preventative compound (C-104) is present on the nut threads and, while holding the outboard nut, apply 575 to 600 foot-pounds torque to the inboard nut using P/N 214-210-001-101 Wrench.

2) Perform steps 2.a.1) and 2.a.2) above.

3) Repeat the torque check each succeeding 10 to 25 hours until the torque stabilizes in the correct range.

b. 214B Component Repair & Overhaul Manual, BHT-214B-CR&O, Chapter 65, Rotors:

1) *Revise and add the following paragraphs*

65-6. ALIGNMENT – MAIN ROTOR HUB AND BLADES

11. Adjust length of drag braces until plumb bobs are directly above alignment marks on grips as follows:

NOTE: The drag brace is assembled with corrosion preventative compound, C-104, on the nut threads. Assure this compound is present on threads prior to application of torque.

a. For P/N 214-010-113-107, use T101887 wrench on inboard nut and T102037 wrench on outboard nut and holding outboard nut, torque inboard nut 375 to 425 foot pounds.

b. For P/N 214-010-191-101, hold the outboard nut and using 214-210-001-101 Wrench, torque inboard nut 575 to 600 foot pounds.

12A Lockwire (C-405) drag brace inboard and outboard nuts together and apply corrosion preventative compound (C-101) to nuts and exposed barrel threads. Allow compound to dry to the touch before flight.

2) *Revise the following paragraph*

65-8 DISASSEMBLY – MAIN ROTOR HUB

7.f. Remove nut (16, figure 65-3), bolt (8), and washers (7) and

remove drag brace (17) from grip. Remove bolt (15), washers (7), and nut (16). Disassemble drag brace (17) as follows:

1) P/N 214-010-113-107 - Restrain outboard nut with T102037 Wrench and loosen inboard nut with T101887 wrench; remove outboard nut, chamfered washer, clevis, and inboard nut from the barrel.

2) P/N 214-010-191-101 - Restrain outboard nut and loosen inboard nut with 214-210-001-101 Wrench; remove outboard nut, chamfered washer, clevis, and inboard nut from the barrel.

3) *Reference Figure 65-8*

Use Figure 2 of this technical bulletin for damage limits for the P/N 214-010-191-101 drag brace assembly.

4) *Reference Figure 65-14*

Use Figure 3 of this technical bulletin for processing requirements for the P/N 214-010-191-101 drag brace assembly.

5) *Revise the following paragraph*

65-14 REASSEMBLY – MAIN ROTOR HUB

2.e. Assemble drag brace as follows:

(1) Apply corrosion preventative compound (C-104) to nut threads.

(2) Assemble inboard nut, clevis, chamfered washer, and outboard nut on drag brace barrel and adjust nuts until drag brace will fit on pins of T102036 drag brace spacing tool.

NOTE: Do not torque nuts. Final torque will be accomplished after blade alignment.

(3) Tighten inboard nut finger tight plus 1/2 turn while holding outboard nut.

- c. 214B Illustrated Parts Breakdown Manual, BHT-214B-IPB, Chapter 62.

Reference Figure 62-3

Refer to Figure 1 of this technical bulletin for P/N 214-010-191-101
Drag Brace Assembly detail parts information.

- NOTES: 1. APPLY MIL-C-16173 GRADE 2 COMPOUND ON NUT THREADS DURING ASSEMBLY. ENSURE COMPOUND IS PRESENT ON NUT THREADS PRIOR TO APPLICATION OF TORQUE.
2. TORQUE INBOARD NUT 575 TO 600 FOOT-POUNDS USING P/N 214-210-001-101 CROWFOOT WRENCH.
3. AFTER FINAL ADJUSTMENT AND NUT TORQUE, APPLY MIL-C-16173 GRADE 1 COMPOUND TO NUTS AND EXPOSED BARREL THREADS.

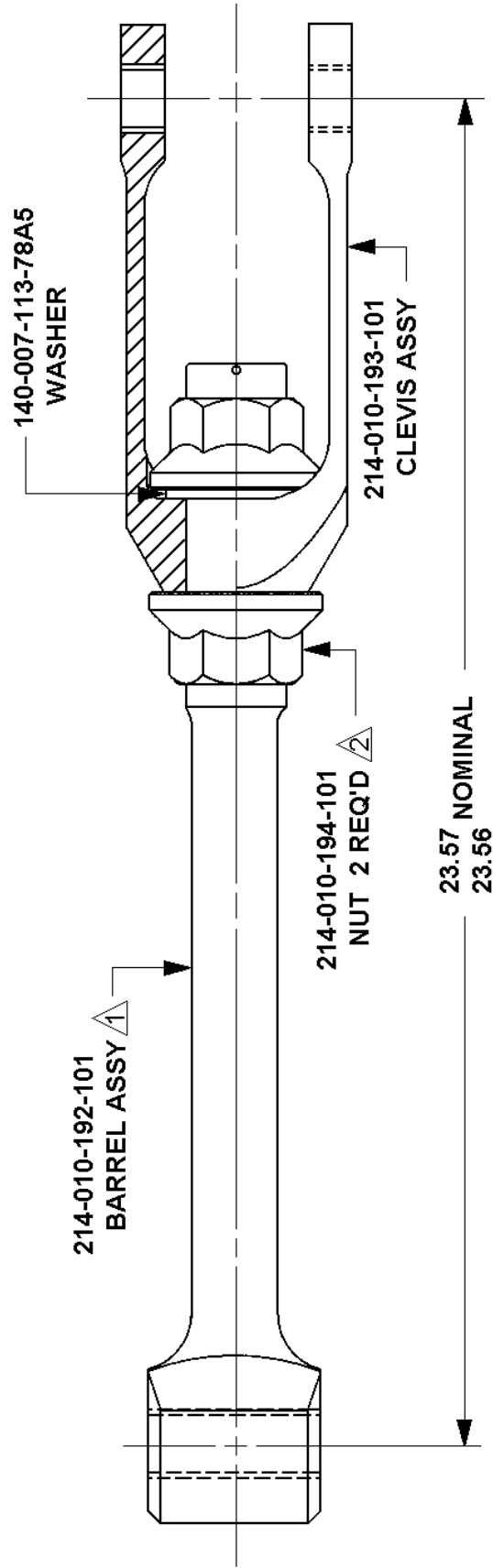
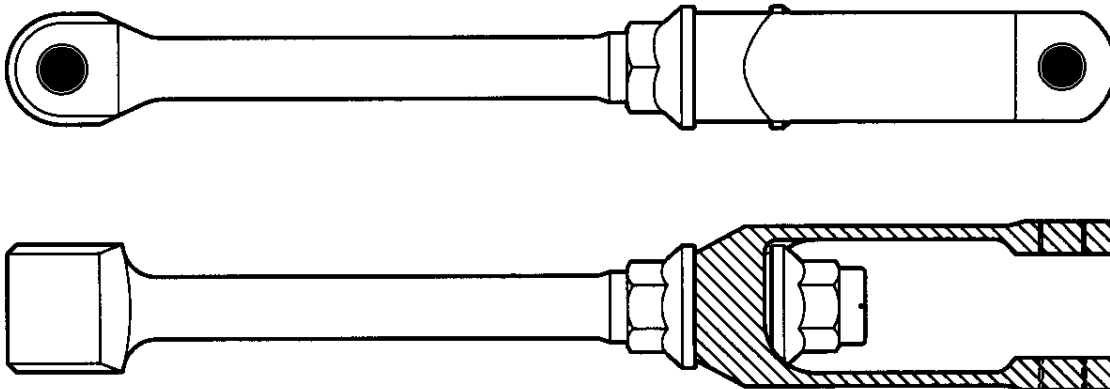

FIGURE 1
P/N 214-010-191-101 DRAG BRACE ASSEMBLY



214-010-191-101
DRAG BRACE ASSEMBLY

DAMAGE AREA REPAIR SYMBOLS



MAXIMUM DEPTHS AND REPAIR AREAS

TYPE OF DAMAGE		
MECHANICAL DAMAGE:	0.010 (0.254 mm)	0.010 (0.254 mm)
CORROSION DAMAGE:	0.010 (0.254 mm)	0.010 (0.254 mm)
MAXIMUM AREA PER FULL DEPTH REPAIR:	0.40 Sq. In. (258 Sq. mm)	0.20 Sq. In. (129 Sq. mm)
NUMBER OF REPAIRS: (NON OVERLAPPING)	4	2
EDGE CHAMFER:	0.040 In. (1.016 mm)	0.040 In. (1.016 mm)
MOUNT BOLT BORE ● DAMAGE:	0.001 In. (0.0254 mm) for 1/4 circumference	
CRACKS:	NONE	NONE
THREAD DAMAGE:	DEPTH: 1/3 of thread depth LENGTH: 0.25 (6.35 mm) NUMBER: 2	

NOTES

1. No damage allowed to thread roots on barrel.
2. Mechanical damage or corrosion damage to thread roots is caused for rejection and scrapping of part.
3. All dimensions are in inches unless otherwise noted.

FIGURE 2

214ST-R-62-26-8

NOTES

1. Omit prime and paint from bottom of nuts.
2. Omit prime and paint from all hole and bushing bores, except note 5 and all threads.
3. One coat epoxy polyamide primer and two coats of acrylic lacquer all exterior surfaces except where noted.
4. Cadmium plated surfaces. Refer to BHT-ALL-SPM for touchup procedures.
5. Fill I.D. of barrel with one coat of epoxy polyamide primer and drain.

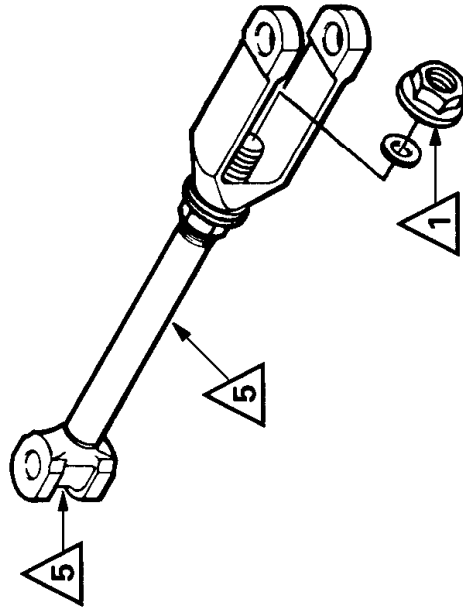

FIGURE 3