

TECHNICAL BULLETIN
Bell Helicopter **TEXTRON**

A Subsidiary of Textron Inc.

No. 407-05-69

Date Jul 26, 2005

Page 1 of 4

| |
|------|
| DATE |
| REV |

MODEL AFFECTED: 407

SUBJECT: IMPROVED FREEWHEEL AFT SEAL P/N 209-340-265-103, INTRODUCTION OF

HELICOPTERS AFFECTED: 407 helicopters serial number 53000 through 53632.
Helicopters serial number 53632 and subsequent will have the intent of this bulletin accomplished prior to delivery.

COMPLIANCE: At Customer's Option

DESCRIPTION:

This bulletin is issued to introduce a new freewheel aft seal 209-340-265-103. It is anticipated that this seal will improve reliability and life over the seal currently used.

APPROVAL:

The engineering design aspects of this bulletin are Transport Canada approved.

MANPOWER:

No additional man-hours will be required when the seal replacement is accomplished at freewheel overhaul.

MATERIALS:

The material that follows is required to do this bulletin and can be obtained through your Bell Helicopter Textron Supply Center.

| <u>Part Number</u> | <u>Nomenclature</u> | <u>Quantity</u> |
|--------------------|---------------------|-----------------|
| 209-340-265-103 | SEAL | 1 |

Consumable Material:

The following material is required to accomplish this bulletin, however this material is considered consumable (bench stock) material and may not require ordering depending on the operators consumable material stock levels. This material may be obtained through your Bell Helicopter Textron Supply Center.

| <u>Part Number</u> | <u>Nomenclature</u> | <u>Reference</u> |
|--------------------|---------------------|------------------|
| ACETONE GALLON | SOLVENT | C-316 |
| AMS-S-8802 6OZ | SEALANT | C-308 |

SPECIAL TOOLS:

Not required

WEIGHT AND BALANCE:

Not affected

ELECTRICAL LOAD DATA:

Not affected

REFERENCES:

BHT-407-MM, Revision 20, November 12, 2004.
Chapter 63, Main Rotor Drive

PUBLICATIONS AFFECTED:

BHT-407-MM, Revision 20, November 12, 2004.
Chapter 63, Main Rotor Drive

BHT-407-IPB, Revision 3, September 06, 2002.
Chapter 63, Main Rotor Drive

BHT-407-CR&O, Revision 2, March 09, 2004.
Chapter 63-30, Drive System Freewheel

ACCOMPLISHMENT INSTRUCTIONS:

1. Install the new seal as follows:
 - a. Clean the aft bearing cap (2, Figure 1) with solvent (C-316).
 - b. Heat the aft bearing cap (2) to $250^{\circ}\text{F} \pm 10^{\circ}$ ($121^{\circ}\text{C} \pm 5^{\circ}$).

CAUTION

DO NOT USE A HYDRAULIC PRESS TO INSTALL THE SEAL. USE A MANUAL ARBOR PRESS TO CONTROL THE FORCE APPLIED ON THE SEAL FACE.

-NOTE-

Do not apply sealant to the outer diameter of the seal (figure) or to the inside diameter of the aft bearing cap.

- c. Press seal (1) into the aft bearing cap (2) with the seal recess facing inboard. Push the seal (1) into the aft bearing cap (2) evenly and smoothly until seated.
 - d. Apply a small beat of sealant (C-308) as shown in figure 1.
2. Complete the installation of the freewheel assembly (BHT-407-MM, Chapter 63)
3. Perform a ground run for 5 minutes at 100% NR and inspect for leaks.
4. Make an entry in the helicopter Historical Record to show that this Technical Bulletin is completed.

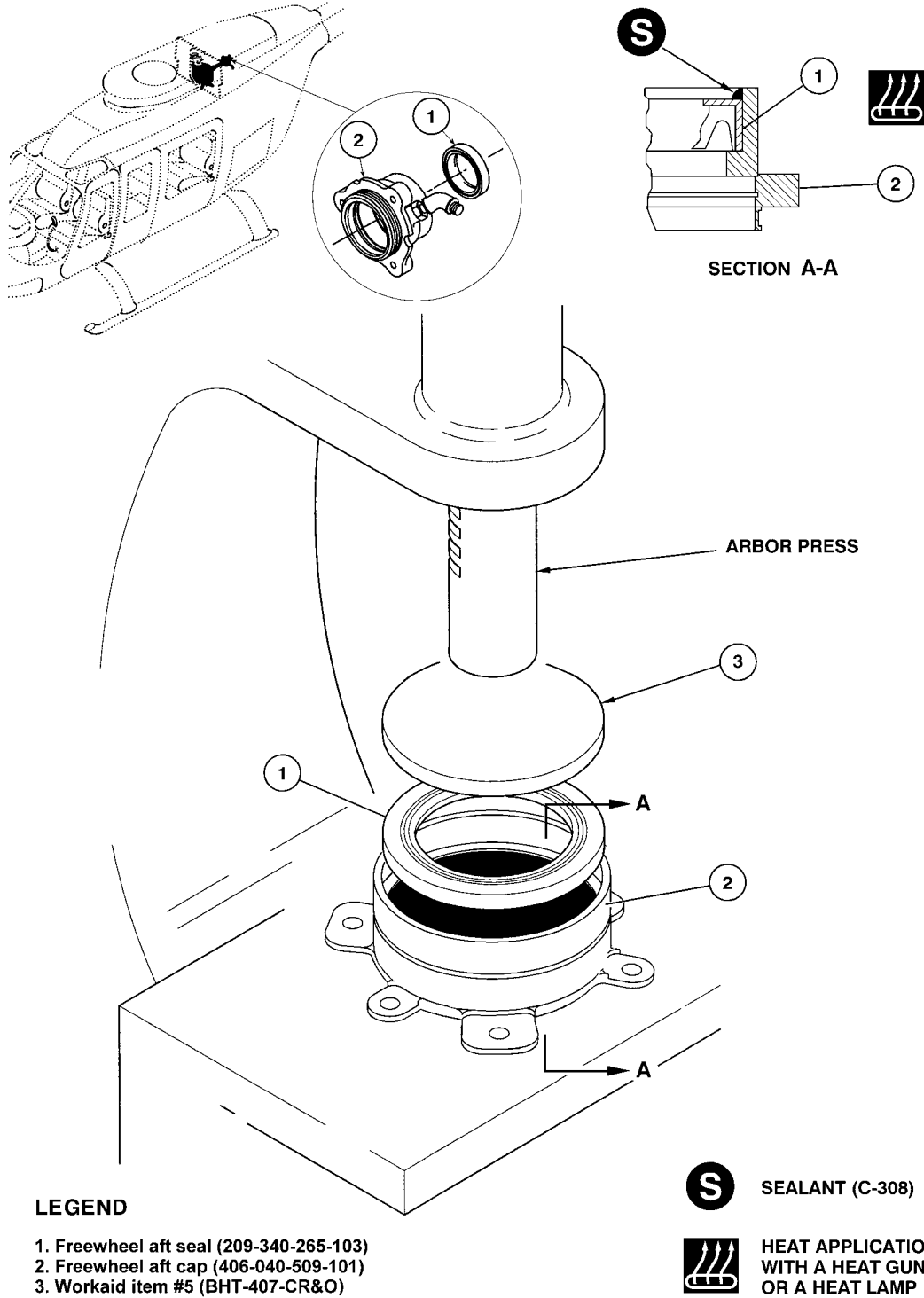

04594001

Figure 1. Seal 209-340-265-103 - Installation