



Aug 21, 2009

TO: All Owners/Operators of Bell 407 Helicopters

**SUBJECT: REVISION "B" TO TECHNICAL BULLETIN 407-07-75:
FADEC ECU EMC-35 WITH REVERSIONARY GOVERNOR,
INTRODUCTION OF.**

Revision "B" to this bulletin only changes the CEB 73-6048 reference from revision 2 to revision 3 issued by Rolls Rolls March 16, 2009.

TECHNICAL BULLETIN
Bell *helicopter*

No. 407-07-75

A Textron Company

Date JAN 29, 2007

Page 1 of 8

DATE Aug 21, 2009

REV B

MODEL AFFECTED: 407

SUBJECT: FADEC ECU EMC-35R WITH REVERSIONARY GOVERNOR, INTRODUCTION AND INSTALLATION OF.

HELICOPTERS AFFECTED: PART I

Model 407 helicopters serial number 53000 through 53749 with FADEC software version 5.202.

PART II

Model 407 helicopters serial number 53000 through 53927 with FADEC software version 5.356.

[Model 407 helicopters serial number 53928 and subsequent will have the intent of this bulletin accomplished prior to delivery]

COMPLIANCE: In accordance with Rolls Royce Corporation Commercial Engine Bulletin, CEB 73-6048 Revision 3 (dated March 16, 2009).

-NOTE-

Rolls-Royce Corporation will contact all operators and coordinate the reversionary governor upgrade campaign. This bulletin and Flight Manual revision are only to be incorporated once the required material is received from Rolls-Royce Corporation, in conjunction with accomplishment of CEB 73-6048 Revision 3 (dated March 16, 2009).

-NOTE-

You must have completed TB 407-04-54 Rev A, dated February 24, 2004 before you complete this bulletin.

DESCRIPTION:

Rolls-Royce Corporation has introduced a product improvement for the Model 250 Series IV FADEC single engine control system with the addition of a Reversionary Governor to the EMC-35A Electronic Control Unit (ECU). This improved ECU designated EMC-35R should reduce the frequency of reversions to manual mode.

Since the introduction of the EMC-35R to the field, various nuisance faults have been experienced (Ref CSL 6125 Revision 2, dated September 17, 2008). Rolls Royce has revised CEB 73-6048 introducing a software upgrade that should eliminate these various nuisance faults.

This bulletin in conjunction with CEB 73-6048 Revision 3 provides instructions for the replacement of the Electronic Control Unit (ECU) EMC-35A with the Reversionary Governor ECU EMC-35R with the latest software version 5.358 or software upgrade only for helicopters currently equipped with the Reversionary Governor ECU with software version 5.356.

APPROVAL:

The engineering design aspects of this bulletin are TCCA approved.

MANPOWER:

Approximately 2.0 man-hours are required to complete this bulletin. Man-hours are based on hands-on time, and may vary with personnel and facilities available.

WARRANTY:

In accordance with Rolls-Royce Corporation Commercial Engine Bulletin, CEB 73-6048 Revision 3 (dated March 16, 2009).

MATERIALS:

Required Material:

The following material is required for the accomplishment of this bulletin.

<u>Part Number</u>	<u>Nomenclature</u>	<u>Quantity</u>	<u>Applicability</u>
407-075-011-113	Decal	1 (Notes 1, 2)	PART I and II
NAS6203-14	Bolt	3 (Note 1)	PART I
NAS6203-20	Bolt	1 (Note 1)	PART I
NAS43DD3-72N	Spacer	1 (Note 1)	PART I
NAS43DD3-128N	Spacer	1 (Note 1)	PART I
MS27039-1-26	Screw	1 (Note 1)	PART I
MS27039-1-40	Screw	1 (Note 1)	PART I

Note 1: The required material for PART I will be supplied by Rolls-Royce Corporation as part of the Reversionary Governor upgrade campaign.

Note 2: The decal may be locally manufactured using lettering of white color no. 17875, on a black background color no. 17038 per FED STD595. Characters to be 12 points Helvetica Regular, the text for the decal is detailed in figure 2, detail C.

Consumable Material:

The following material is required to accomplish this bulletin; however this material is considered consumable (bench stock) material and may not require ordering depending on the operator's consumable material stock levels. This material may be obtained through your Bell Helicopter Textron Supply Center.

<u>Part Number</u>	<u>Nomenclature</u>	<u>Quantity</u>	<u>Reference</u>
TT-N-95, TYII 1GAL	Naphtha		C-305
3950 Scotchcal	Sealer		C-349

SPECIAL TOOLS:

None required

WEIGHT AND BALANCE:

PART I

<u>Weight</u>	<u>Arm</u>	<u>Longitudinal Moment</u>	<u>Arm</u>	<u>Lateral* Moment</u>
+2.5 Lbs (+1.1 kg)	104.5 in. (2654 mm)	+261.0 in-Lbs (+30.1 kg x mm/100)	8.0 in. (203 mm)	+20.0 in-Lbs (+2.3 kg x mm/100)

* In lateral calculations, - is left and + is right.

PART II

Not affected

ELECTRICAL LOAD DATA:

Not affected

REFERENCES:

BHT-407-MM Maintenance Manual
Chapter 53 – Fuselage

BHT-407-MM Maintenance Manual
Chapter 76 – Engine Controls

BHT-407-MM Maintenance Manual
Chapter 96 – Electrical Systems

Rolls-Royce Commercial Engine Bulletin
CEB 73-6048 Revision 3 (dated March 16, 2009)

Rolls-Royce Commercial Service Letter
CSL-6125 Revision 2 (date September 17, 2008)

PUBLICATIONS AFFECTED:

BHT-407-MM Maintenance Manual
Chapter 76 – Engine Controls

BHT-407-IPB Illustrated Parts Breakdown
Chapter 76 – Engine Controls

BHT-407-IPB Illustrated Parts Breakdown
Chapter 96 – Electrical

BHT-407-FM-1 Rotorcraft Flight Manual

BHT-407-MD-1 Rotorcraft Manufacturer's Data

ACCOMPLISHMENT INSTRUCTIONS:

PART I

1. Refer to CEB 73-6048 Revision 3 (dated March 16, 2009) Accomplishment Instructions Step B, for recording of the engine information before ECU removal.
2. Disconnect battery.
3. Gain access to right hand side of transmission deck by removing the appropriate cowlings (BHT-407-MM, Chapter 53 – Fuselage).

-NOTE-

Retain clamps (1, figure 1) and washers (2) removed in step below for re-installation. Discard screws and spacers.

4. Disconnect clamps (1) currently holding the cable assemblies 407-375-012-101 (or 407-076-503-111) and 407-375-012-103 (or 407-076-503-109) to the roof deck that are adjacent to the ECU connectors 1A50P1 and 1A50P2. Refer to Figure 1.
5. Disconnect the FADEC harness electrical connectors 1A50P1 and 1A50P2 from the ECU.
6. Remove the screw (3), lock washer (4), washer (5) and the bonding strap from the ECU. Retain hardware.

-NOTE-

Retain washers (6) removed in step below for re-installation. Discard bolts and spacers.

7. Remove bolts, washers (6) and spacers holding the ECU to the deck.
8. Remove ECU P/N 23072790.
9. Install ECU P/N 23088484 using hardware as shown in Figure 1.

10. Re-install bonding strap using screw (3), lock washer (4), washer (5) onto the ECU.
11. Ensure connectors 1A50P1 and 1A50P2 are clean and in a serviceable condition and install to the ECU. If applicable, re-install clamp (1) and washers (2), removed in Step 4, and spacers (9 and 10). Refer to Figure 1
12. Using a plastic scraper, remove and discard FADEC software version decal 407-075-011-109 or -111 located on the instrument panel. Wipe surface clean with a clean damp cloth, dampened with Naphtha (C-305).
13. Install decal 407-075-011-113 on instrument panel. Refer to Figure 2.
14. Seal edges of decal using edge sealer (C-349).
15. Re-install all cowlings previously removed (BHT-407-MM, Chapter 53 – Fuselage).
16. Insert the Flight Manual revision 8 and temporary revision (TR-12) dated January 13, 2009 into BHT-407-FM-1 Flight Manual.
17. Connect battery.
18. Comply with CEB 73-6048 Revision 3 (dated March 16, 2009) applicable operational checks and FADEC functional checks (BHT-407-MM, Chapter 76 and 96).
19. Make an entry in the helicopter and engine logbook to show that this Technical Bulletin has been completed.

PART II

-NOTE-

Software upgrade is performed by either Goodrich Engine and Control Systems (GECS) or Rolls-Royce Corporation (RRC) representative only.

1. Contact your local Rolls-Royce Corporation representative to schedule the software upgrade activity.
2. GECS or RRC representative to upload new FADEC software version 5.358 into ECU.
3. Perform steps 11 through 19 of PART I.

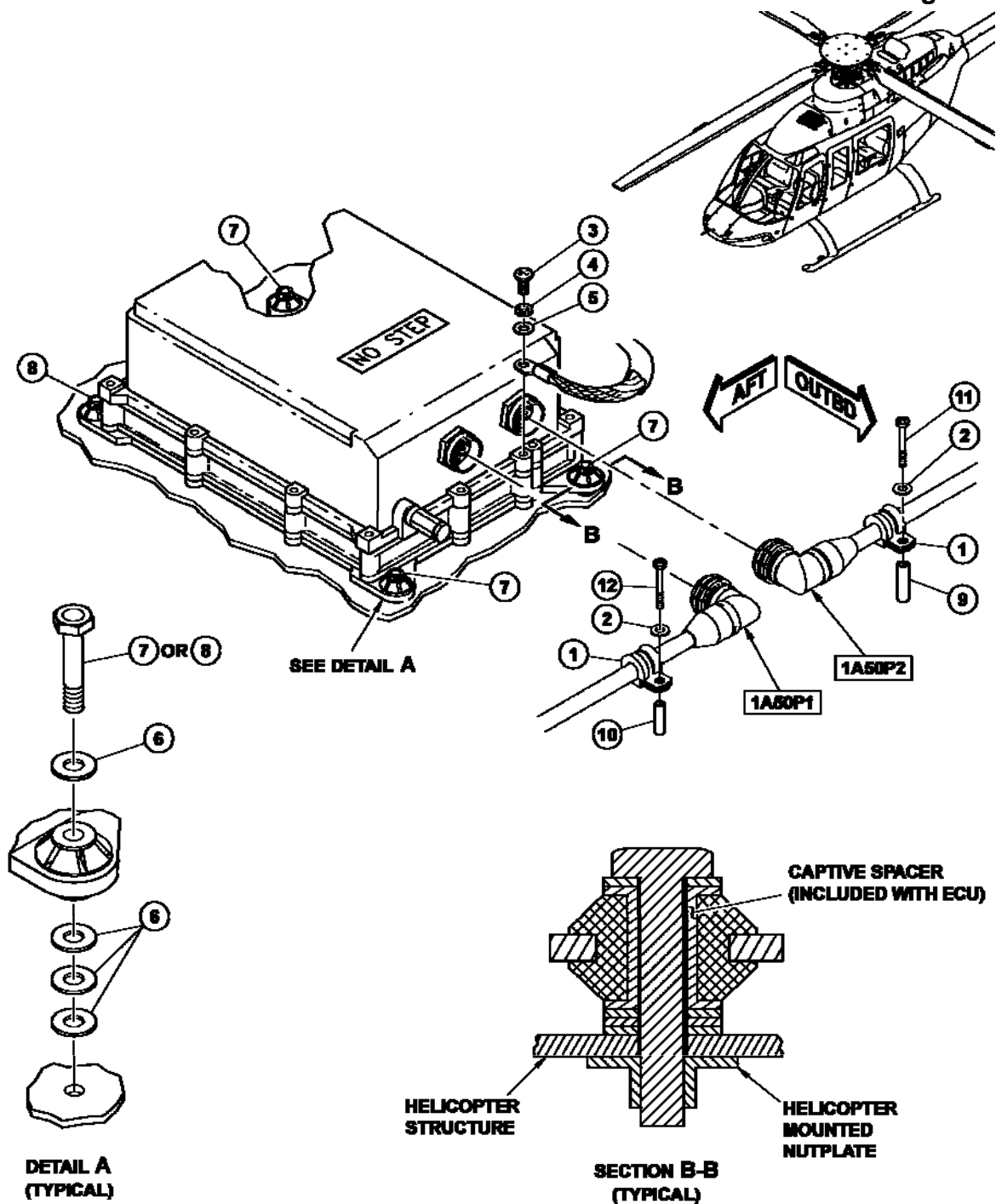

08574_001

LEGEND

- | | | |
|---------------------------|---------------------------|---------------------------------|
| 1. Clamp (existing) | 5. Washer (existing) | 9. NAS43DD3-72N Spacer, Qty 1 |
| 2. Washer (existing) | 6. Washer (existing) | 10. NAS43DD3-128N Spacer, Qty 1 |
| 3. Screw (existing) | 7. NAS6203-14 Bolt, Qty 3 | 11. MS27039-1-26 Screw, Qty 1 |
| 4. Lock-washer (existing) | 8. NAS6203-20 Bolt, Qty 1 | 12. MS27039-1-40 Screw, Qty 1 |

FIGURE 1. ECU installation

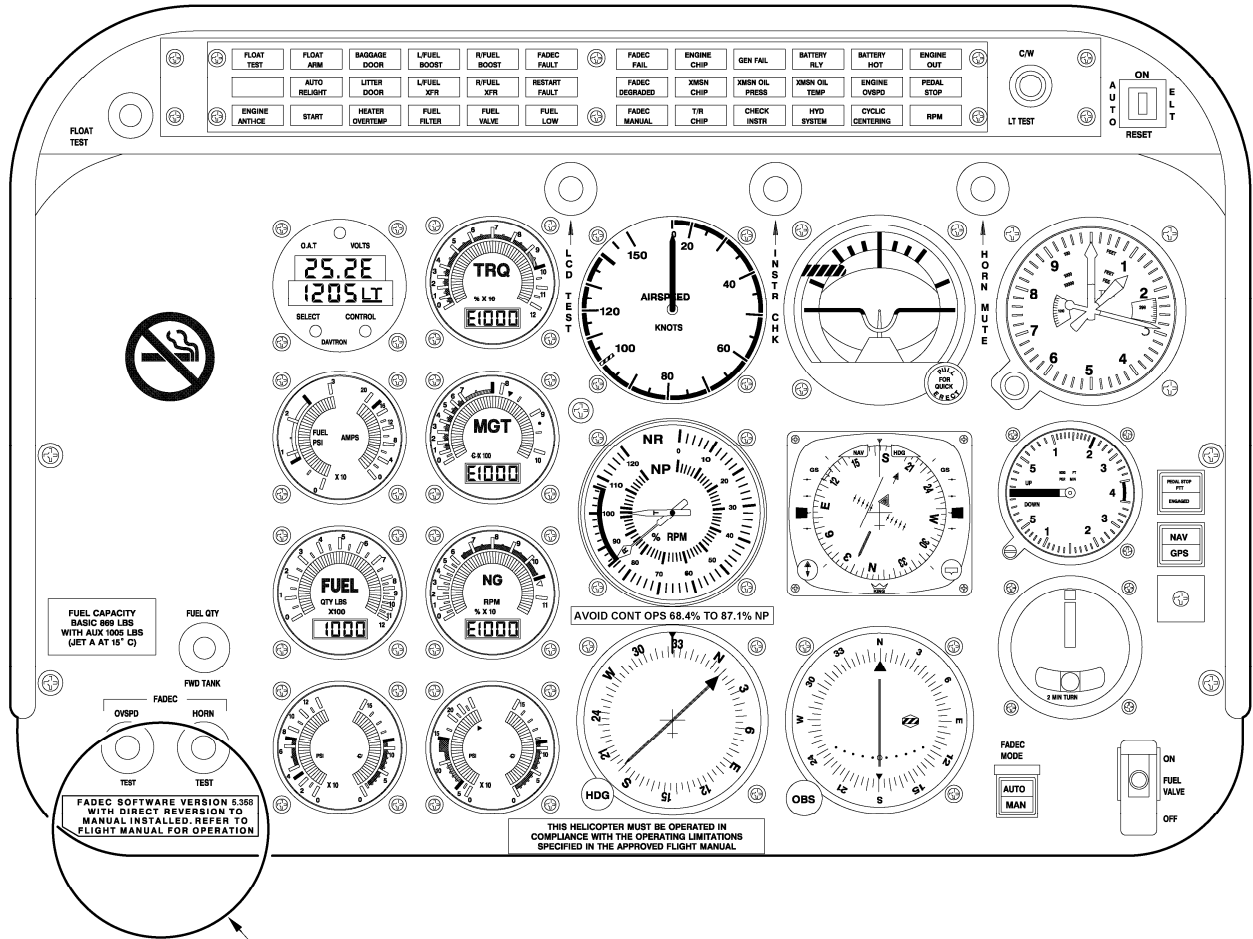

SEE DETAIL C

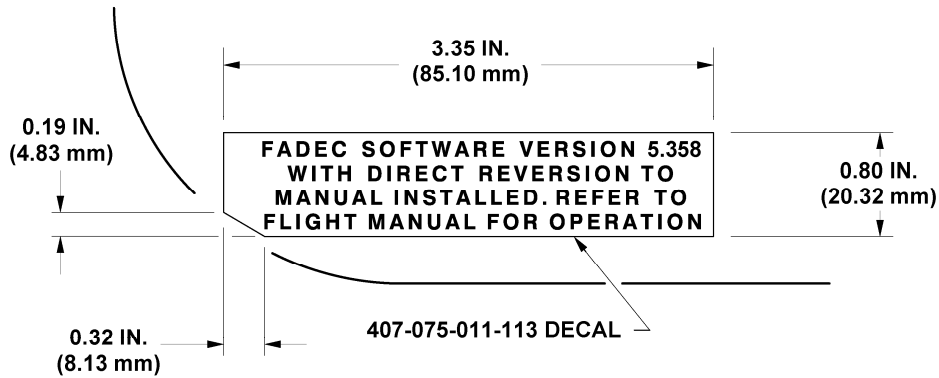

DETAIL C

06574_002

Figure 2. Instrument Panel Decal Location